

Vanderbilt University

Architectural and Engineering Standards

June
2021

Vanderbilt University Campus Planning and Construction
Baker Building 11th Floor
Nashville, TN 37240
Phone: 615 322 2715, Fax: 615 343 4830
www.vanderbilt.edu/campusplanning
Copyright © 2021 by Vanderbilt University

SECTION 00 00 01 - PREFACE

Part 1 – General

1.01 Statement of Intent

Vanderbilt University, founded in 1873, is an internationally recognized research university in Nashville, Tennessee. The university seeks to “strengthen the ties that should exist between all sections of our common country” and has strong partnerships among its ten schools, neighboring institutions and the metro Nashville community. The Vanderbilt campus encompasses 333 acres and is located one and a half miles southwest of downtown metro Nashville. The original eleven building campus now includes 179 buildings and over nine million square feet of built space. Vanderbilt is home to more than three hundred tree and shrub varieties and was designated as an arboretum in 1988. FutureVU, Vanderbilt’s campus land use plan, developed over the last several years, has the goal of ensuring that the university campus is designed and prepared at every level to support its students, faculty and staff, and to uphold the university’s mission and values. FutureVU articulates a comprehensive vision for the university’s footprint and provides a basis for campus stewardship that enhances the university’s mission. With Metro Nashville’s unprecedented growth in recent years, the university aims to be viewed as an elite institution, not elitist, to maintain its ties with the surrounding metro Nashville community and not be insular to the changes occurring around the university campus. FutureVU objectives are to:

- Create standards for facilities and landscapes that embody our commitment to diversity and inclusion;
- Improve the collegiate environment and foster the notable success of the residential college experience;
- Enhance trans-institutional collaboration, research, and development;
- Adopt an ethic of sustainability;
- Support community outreach and connectivity, and the “One Vanderbilt” principles of collaboration that are an important element of Vanderbilt’s uniqueness.

To attain these goals, FutureVU will guide investment in physical space, providing a framework for the development of campus for the next twenty to thirty years, while considering core themes such as diversity and inclusion, environmental sustainability, connectivity and community enhancement, increased development around campus, transportation, and preservation of the historic park-like setting. [FutureVU is built on a set of guiding principles](#) that directly relate to Vanderbilt’s core mission of teaching, research and discovery. These principles state:

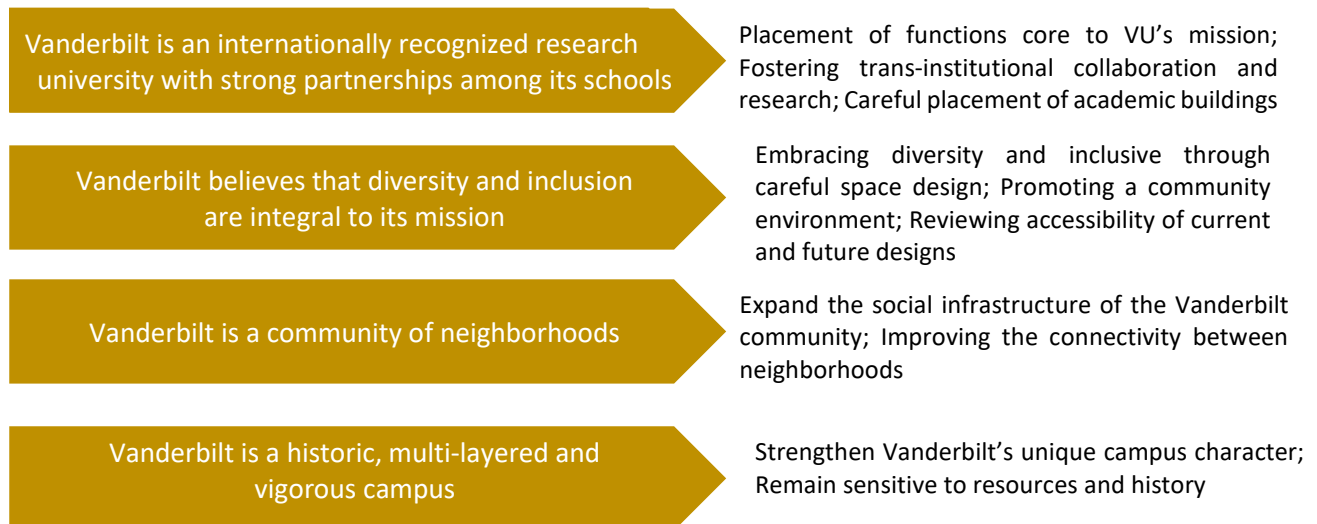

SECTION 00 00 01 - PREFACE

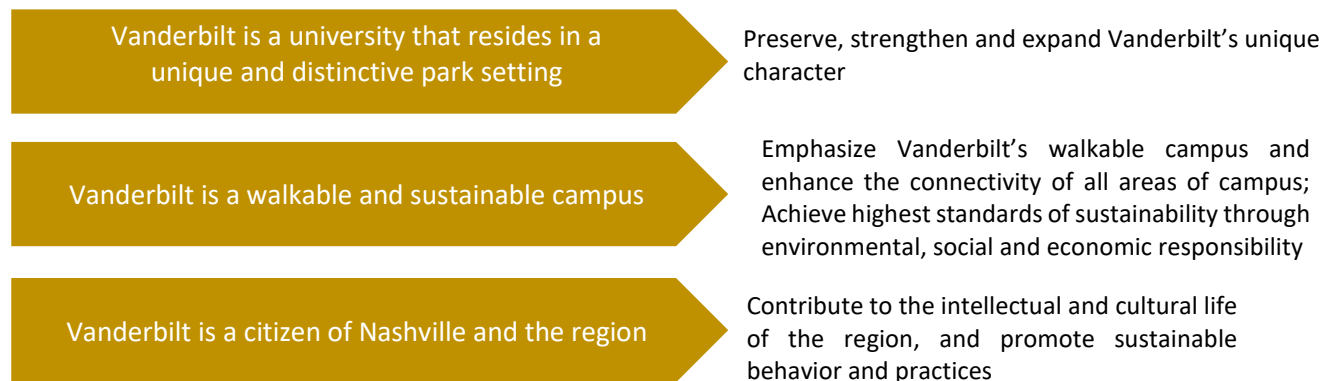

Through FutureVU the university will ensure that the fundamental principles its community cherishes as an institution are manifest in the campus' physical surroundings.

Project design & development should refer to and use the ***Vanderbilt Sustainable Building Standards*** (Appendix A), which summarizes the elements of the Vanderbilt strategic planning process, Future VU, BlueSky Vision, energy and sustainability goals. To best achieve the goals outlined in these Vanderbilt strategic initiatives, all projects will be developed using an Integrated Design Process (IDP) that includes the following specific elements: ***Owner Project Requirements (OPR)***, ***Energy Modeling*** and ***Commissioning***. The Vanderbilt Project Manager will be responsible for determination of the appropriate level of application of these strategic elements to each project based on the scope and nature of the project.

- ***Owner Project Requirements (OPR)*** – the formal discovery and development process that allows the key Vanderbilt stakeholders along with the design team to document all aspects of the project in support of an ***Integrated Design Process (IDP)*** and development of the ***Basis of Design (BOD)***. “*The OPR forms the basis from which all design, construction, acceptance and operational decisions are made*” (ASHRAE – OPR).
- ***Energy Modeling (EM)*** – energy modeling services incorporated into the design development process as required to help ensure the guiding principles outlined in the ***Vanderbilt Sustainable Building Standards*** (Appendix A) are addressed in support of and in conjunction with the established Vanderbilt Master Planning, energy performance and sustainability goals.
- ***Commissioning*** – all Vanderbilt projects will incorporate commissioning services. The Vanderbilt Project Manager will be responsible for determination of the appropriate level of commissioning required for each project. Contracted commissioning services will be engaged in the design development process and will be responsible to the owner for the documentation of the ***Owner Project Requirements (OPR)***. Contracted commissioning agents will also be responsible for the validation of the applied design to the ***Vanderbilt Sustainable Building Standards*** (Appendix A) and resulting energy performance to the energy model.

These architectural and engineering standards are intended to provide general guidelines for architects, engineers, and any other contracted design consultant involved in the planning, design, and construction of any aspect of the grounds and utilities, of renovations to the existing infrastructure, and of new facilities on all property on the main campus of Vanderbilt University. Designers are responsible for all divisions of this manual and are to incorporate the appropriate information early in the design process.

SECTION 00 00 01 - PREFACE

The information contained herein is supplemental in nature and is not intended to conflict with, repeat, or supersede recognized industry standards and governing agencies; nor is it to limit design creativity or the exploration of changing technologies. The intent is to consolidate into one format those items on which this campus applies specific practices or standardization that might not be recognized or known as generally accepted practice.

The manual is organized to follow the divisions of the Construction Specifications Institute (CSI) in format and numbering. Where possible, we have tried to place the items that have been included in categories under titles that exist within the CSI.

The Designer should reference the VU Campus Planning and Construction (CPC) website for the most current version of these sections and for additional information not contained within this document. The website address is www.vanderbilt.edu/campusplanning.

1.02 Definitions

The following terms used throughout this manual are defined as follows:

OWNER: Vanderbilt University

CONTRACTOR: Private sector party under contract to execute work as specified by Designer in contract documents; includes Construction Manager (CM) when such arrangement is used.

DESIGNER: Private sector party under contract to provide contract documents necessary to direct Contractor(s) to satisfy program requirements as stated by University client; typically architects, engineers, landscape architects, etc.

SECTION 00 00 01 - PREFACE**1.03 Organizational Summary**

All contracts entered into on behalf of Vanderbilt University for the design of, or for bringing about any alterations to, the physical structure of any facility, utility, support infrastructure and the exterior environment for campus buildings are assigned between the Campus Planning & Construction Department or Plant Operations, depending upon the nature of the specific work required.

A Project Manager is assigned to handle coordination of all interaction between the University party requesting the work and the private sector Designer or Contractor. No direct contact shall be made with any campus client without prior agreement through the Project Manager.

General Phone Numbers:

Campus Planning & Construction

Ph: 615-322-2715

Fax: 615-343-4830

Plant Operations

Ph: 615-343-9675

Fax: 615-343-4806

Part 2 – Products**Part 3 – Execution**

END OF SECTION –

SECTION 00 01 10 - TABLE OF CONTENTS

DIVISION 0	BIDDING AND CONTRACT REQUIREMENTS	
00 00 01	Preface	2 pages
00 01 10	Table of Contents	4 pages
00 21 00	Instructions to Designers	4 pages
	<i>VU - Project Manual Guidelines</i>	<i>5 pages</i>
00 80 00	Design Concepts	2 pages
00 90 00	Addenda and Modifications	1 page
00 95 00	Air Quality Permitting	1 page
DIVISION 1	GENERAL REQUIREMENTS	
01 06 70	Accessibility	3 pages
01 14 19	Use of Site	3 pages
<i>01 14 19 01</i>	<i>Sample – Site Use Map</i>	<i>1 page</i>
<i>01 14 19 02</i>	<i>Sample – VU Card Shop – Card Request</i>	<i>1 page</i>
<i>01 14 19 03</i>	<i>Sample – Construction and Maintenance Parking request</i>	<i>1 page</i>
01 15 00	Site Utility Protocol	2 pages
01 35 13	Special Project Procedures	1 page
01 35 13 01	<i>Sample – Cutting and Welding Permit (FM Global Tag Permit)</i>	<i>1 page</i>
01 51 00	Temporary Utilities	2 pages
<i>01 51 00 01</i>	<i>Sample – Utility Outage Request</i>	<i>1 page</i>
01 55 00	Vehicular Access and Parking	1 page
01 56 00	Temporary Barriers and Enclosures	1 page
01 70 00	Execution and Closeout Requirements	2 pages
	<i>VU – Record Set Deliverable Requirements</i>	<i>3 pages</i>
	<i>VU – Record Set Submittal Review Form</i>	<i>2 pages</i>
01 81 00	Facility Performance Requirements	
01 81 13	Sustainable Design Requirements	Appendix A
01 91 00	Commissioning (abbreviated)	30 pages
DIVISION 2	EXISTING CONDITIONS	
02 41 13	Selective Site Demolition	3 pages
DIVISION 3	CONCRETE	
03 00 00	Concrete	1 page
DIVISION 4	MASONRY	
04 00 00	Masonry	1 page
DIVISION 5	METALS	
05 00 00	Metals	1 page
DIVISION 6	WOOD, PLASTICS and COMPOSITES	
06 00 00	Wood, Plastics and Composites	1
page		
DIVISION 7	THERMAL AND MOISTURE PROTECTION	
07 00 00	Thermal and Moisture Protection	2 pages
07 60 00	Flashing and Sheet Metal	2 pages

SECTION 00 01 10 - TABLE OF CONTENTS

DIVISION 8	OPENINGS	
08 00 00	Openings	3 pages
08 71 00	Doors Hardware	3 pages
08 74 00 01	Sample – Wiring Diagram for Card Access	1 page
DIVISION 9	FINISHES	
09 00 00	Finishes	2 pages
DIVISION 10	SPECIALTIES	
10 11 00	Visual Display Units	1 page
10 21 13	Compartments and Cubicles	1 page
10 28 00	Toilet, Bath and Laundry Accessories	1 page
DIVISION 11	EQUIPMENT	
11 00 00	Equipment-Procurement and Coordination	2 pages
11 81 23	Facade Access Equipment	1 page
DIVISION 12	FURNISHINGS	
12 00 00	Furnishings	2 pages
12 20 00	Window Treatments	1 page
DIVISION 14	CONVEYING EQUIPMENT	
14 20 00	Elevators	2 pages
11 40 00	Lifts	
DIVISION 21	FIRE SUPPRESSION	
21 00 00	Fire Suppression – Water Sprinkler Systems	2 pages
DIVISION 22	PLUMBING	
22 05 00	Common Work Results for Plumbing	1 page
22 07 00	Plumbing Insulation	2 pages
22 10 00	Plumbing Piping	1 page
22 30 00	Plumbing Equipment	1 page
22 42 00	Commercial Plumbing Fixtures	1 page
DIVISION 23	HVAC	
23 05 00	Common Work Results for HVAC	6 pages
23 05 13	General Provisions	5 pages
23 05 19	Meters and Gauges for HVAC Piping	3 pages
23 05 23	General Duty Valves for HVAC Piping	2 pages
23 05 53	Identification for HVAC Piping and Equipment	1 page
23 07 00	HVAC Insulation	3 pages
23 09 00	Instrumentation and Control for HVAC	3 pages
23 09 93	Sequence of Operation	1 page
23 20 00	HVAC Piping and Pumps	2 pages
23 22 00	Steam and Condensate Piping and Pumps	1 page
23 22 23	Steam Condensate Pumps	1 page
23 23 00	Refrigeration Piping	1 page
23 30 00	Air Distribution	3 pages
23 36 00	Air Terminal Units	3 pages

SECTION 00 01 10 - TABLE OF CONTENTS

23 64 00	Chillers	3 pages
23 65 13	Cooling Towers	1 page
23 73 00	Central Station Air Handling Units	3 pages
23 43 00	Packaged Heating & Cooling Units	2 pages
23 80 00	Central Heating & Cooling Distribution Systems	2 pages
23 81 00	Ductless Splits	6 pages
23 82 16	Coils	2 pages
23 82 19	Fan Coil Units	3 pages
23 84 00	Humidity Control	1 page
DIVISION 26	ELECTRICAL	
26 00 00	Basic Materials & Methods	1 page
26 05 13	Medium Voltage Cables	2 pages
26 05 19	Low Voltage Electrical Power Connections	1 page
26 05 23	Controlled Voltage Electrical Power Cables	1 page
26 05 33	Raceways and Boxes for Electrical Service	1 page
26 05 43	Underground Ducts and Raceways for Electric Service	1 page
26 12 16	Dry Type Medium Voltage Transformers	1 page
26 13 16	Medium Voltage Fusible Interrupter Switchgear	2 pages
26 18 16	Medium Voltage Fuses	1 page
26 24 16	Panelboards	2 pages
26 24 19	Motor Control Centers	1 page
26 27 13	Electrical Metering	1 page
26 27 26	Wiring Devices	2 pages
26 35 13	Capacitors	1 page
26 50 00	Lighting	3 pages
DIVISION 27	COMMUNICATIONS	
27 00 00	Communications	2 pages
DIVISION 28	ELECTRONIC SAFETY AND SECURITY	
28 31 00	Fire Detection and Alarms	1 page
DIVISION 31	EARTH WORK	
31 11 00	Clearing and Grubbing	3 pages
31 22 19	Finish Grading	3 pages
31 23 00	Excavation and Fill	10 pages
31 25 00	Erosion Control	4 pages
31 31 16	Termite Control	1 page

SECTION 00 01 10 - TABLE OF CONTENTS

DIVISION 32	EXTERIOR IMPROVEMENTS	
32 01 90.33	Tree and Shrub Preservation	3 pages
32 11 23	Aggregate Base Course	3 pages
32 12 16	Asphalt Paving	5 pages
32 13 13	Concrete Walks and Paving	9 pages
32 17 23	Pavement Markings	2 pages
32 30 00	Site Improvements	2 pages
32 80 00	Irrigation	12 pages
32 90 00	Planting	12 pages

Appendices		
Appendix A	Sustainable Building Standards	
Appendix B	Accessibility Master Plan	
Appendix C	Landscape Strategic Plan	
Appendix D	Mobility Master Plan	
Appendix E	VU Energy Model Standards	

- END OF SECTION-

SECTION 00 21 00 - INSTRUCTIONS TO DESIGNERS**Part 1 – General****1.01 Scope**

Documentation required of the designer and contractor before, during and at the end the Work.

Part 2 – Products**Part 3 – Execution****3.01 Cover Sheet**

1. Project Name
2. Drawing Issue date
3. Project Team
4. Sheet Index

3.02 General Notes Sheet

1. Total Gross Square Feet for the Building by floor
2. Live Load Assumptions for structural design
3. Name and edition of major building codes governing design (codes analysis)
4. General notes, abbreviations and symbols

3.03 Vanderbilt General Conditions of the Contract

The Designer will verify with the Project Manager that Vanderbilt will retain the services of a Construction Manager (CM). When such is the case, the project specifications will include a copy of Vanderbilt's standard General Conditions of the Contract for Construction. A copy of the General Conditions will be furnished to the Designer upon request. If Vanderbilt does not intend to use a CM, the Designer will consult with the Project Manager to determine which General Conditions will be appropriate.

3.04 Drawing Size

Standard sizes for construction drawings for the University are 11"x17", 18"x24", 24"x36", and 30"x42". Larger drawing sizes shall not be used without a compelling reason to do so and must be specifically authorized by the Project Manager and the Office of Facilities and Information Services (OFIS).

3.05 Room Numbering

The Designer's room numbering system should match the University's standard system. Plans shall be submitted early in the process through the Project Manager to the Office of Facilities and Information Services (OFIS) for the creation of room numbers or for the review and approval of a numbering scheme. This should usually be done at the completion of schematic design. Questions can be directed to the Director of the Center at 322-2715. Door numbers should match space numbers. Spaces with more than one door should employ the space number as the initial number of each door, followed by a hyphen and sequential numbers for each door. (Example: Space #206 with three doors numbered 206-01, 206-02, and 206-03 respectively.)

SECTION 00 21 00 - INSTRUCTIONS TO DESIGNERS**3.06 Room Signs**

Plant Operation's Sign Shop can generally produce and install individual door graphics for small renovations. Standard campus prototypes for interior signage do exist and can be clarified through the Project Manager.

3.07 Numbering Systems

Renovations that affect numbering systems for rooms, keying schedules, valve identification system, etc. shall be coordinated with the existing system, with the recommended revisions coordinated with the Director of OFIS and renumber as required.

3.08 Key Schedules

The Designer shall prepare the keying schedule. The keying system and related security issues should be discussed with users during the programming/planning phase. The keying plan includes:

1. General plan for keying the building, including building master, sub-masters, etc.
 - a. Include keying system explanation, door numbers, key set symbols, hardware set numbers and special instructions.
2. Provisions for all mechanical room and utility keys to be keyed under a separate utility master system; these keys will always be cut by the Plant Operations Key Shop.
3. Plans for special locksets for cabinets, storage units, casework, etc. as worked out with the users during the programming/planning phase.
4. See Doors and Door Hardware 08 00 00 for key schedule sample.

3.09 Testing

Requirements for surveying and site investigations required for a project are to be defined by the Designer. The University will contract directly with the firm performing such services. Testing required for concrete, engineered fill, welding inspection, HVAC testing and balancing shall be defined by the Designer. Except for HVAC the University will contract directly with firms performing such services. The General Contractor will contract directly for HVAC test and balancing services.

3.10 Survey Guidelines**1. General**

As an on-going process to develop and maintain our computerized maps, we have established control monuments in strategic locations. All surveys shall be performed using Tennessee State Plane Coordinates, NAD (North American Datum) 83 and NAVD 88. Surveys shall show a tie to two Vanderbilt permanent control monuments. The location and description of these control monuments and underground utility information can be found at Facilities Information Services, 106 Bryan Bldg. and/or contact Mapping (615)343-8394. Vanderbilt University will contract directly with the firm performing such services.

SECTION 00 21 00 - INSTRUCTIONS TO DESIGNERS**2. Survey Types**

- a. **General Property Surveys or Topographic Surveys** will be accepted with accordance to the Standard of Practice for Land Surveyors, see <http://www.tn.gov/sos/rules/0820/0820-03.20110317.pdf>
- b. **Global Positioning System (GPS)** surveys shall be accepted when requested.* All GPS surveys must be in accordance with the Federal Geodetic Control Standards (FGCS). Horizontal and vertical control work must meet or exceed those accuracy specification standards as published by the Federal Geodetic Control Committee, September, 1984, in the bulletin titled "Standards and Specification for Geodetic control Networks" or any subsequently published bulletin modifying such class standards.
- c. **Specific Purpose Surveys** shall be performed as specified by VU project manager but not limited to guidelines in General Property or Topographic Surveys.

Plats and maps shall be stamped or sealed with the surveyor seal and signed by a registered land surveyor and contain, but not limited with the following information:

- The name Vanderbilt University, the grantor or grantee of the property.
- Trees of two-inch (2") caliper and up should be noted.

3. Accuracy

Surveys must meet the minimum accuracy requirements provided by State of Tennessee, Standards of Practice-Category I <http://www.tn.gov/sos/rules/0820/0820-03.20110317.pdf> . When very small lots of one acre or less are encountered, the allowable error shall not exceed 1/10 of a foot of positional accuracy at any corner.

4. Deliverables

Deliverable digital information shall be completed on the Tennessee State Plane Coordinates, NAD 83 and NAVD 88. See [Record Set Deliverable Requirements](#) for complete information and format.

**Surveyor will confirm with VU representative whether GPS survey is appropriate depending on specific initial purpose of survey in question.*

3.11 Spare Parts, Attic Stock and Overages

Spare parts or surplus materials should not be specified without approval of the Project Manager. Exceptions to this include mechanical or electrical parts to be installed adjacent to building equipment for emergency repairs or safety.

3.12 Allowances

The Designer shall include a [Schedule of Allowances](#) in Section 01 21 00 of [Project Manual](#), in which all Allowances contained in Contract Documents are listed. Each Allowance shall be identified as to type (Lump Sum or Unit Cost), dollar amount, brief description, and specification Section wherein Allowance is described in greater detail.

SECTION 00 21 00 - INSTRUCTIONS TO DESIGNERS**3.13 Alternates**

The Designer shall include a Schedule of Alternates in Section 01 23 00 of the Project Manual, in which all Alternates contained in Contract Documents are numbered and listed. Each Alternate shall be identified by a brief description and referenced Section(s) and/or Drawing(s) wherein Alternates are described in greater detail. Alternates should be identified as, "Required" or "Voluntary" for prospective Bidders and generally be structured as add alternates.

3.14 Submittals

1. Vanderbilt University's standard General Conditions, contain information regarding Contractor, Construction Manager, and Architectural/Engineering responsibilities with respect to Submittals. The Designer should expect to review and approve, or reject all submittals required by Specifications. This includes submittals relating to energy modeling, renewable energy, and life cycle costing assessments carried out. See the Sustainable Building Standards (SBS) (Appendix A) for more details on modeling and required assessments. The Designer should specify that the CM copy the Project Manager on all submittals for Division 7, 21-23, 25-28. The Designer should copy the Project Manager on all approved submittals when returning them to the CM.
2. The Contractor shall receive and review all shop drawings; they are then forwarded simultaneously to the Designer and Project Manager. The Project Manager shall advise the Designer within seven (7) days of any University concerns regarding the shop drawings. The Designer shall review and approve all shop drawings; approved drawings shall be stamped and signed by the Designer.
3. For time savings a joint shop drawing review with the designers, project manager and contractor may be required in order to expedite delivery time. The Project Manager will organize the time and date of this meeting.

3.15 Existing Drawings

OFIS maintains record drawings for the University, including site drawings, utility drawings, and building drawings. Arrange in advance through the Project Manager to review what coverage is available or schedule directly through the Center at 615 322-2715. Drawings may be researched or reproduced by that office, with direct costs charged to the project. A location service shall be used on all projects to locate in-ground services, unless the Project Manager permits otherwise. Site utilities and building documents are available on line. The website address is www.vanderbilt.edu/campusplanning.

3.16 Field Drawings

Specifications shall include instructions to Contractors to maintain a set of Contract Documents in clean, undamaged condition, with notations of installations which vary significantly from the work as originally shown for the purpose of record drawings. Particular attention should be paid to concealed work.

3.17 Record Drawings

The Designer shall be responsible for preparing a set of CAD files incorporating all changes in the work made during construction based on marked-up prints, drawings, or other data furnished to the Designer. The Designer should refer to (1) the Record Set Deliverable Requirements and (2) Record Set Quality Assurance Review. Both of these documents may be found in section 01 70 00, Project Closeout or viewed online at www.vanderbilt.edu/campusplanning.

SECTION 00 21 00 - INSTRUCTIONS TO DESIGNERS**3.18 Line Drawings**

Provide CAD files indicating all "as-built" walls and structure, Vanderbilt approved room numbers, gross square footage per floor, north arrow, and graphic scale. Final product to adhere in format and style to existing "Line Drawings" presently maintained at the OFIS, Room 106, Bryan Building. Project Manager may waive development of such drawings in case of minor renovations which may be more efficiently updated by in-house staff.

3.19 Trademark and Logo's

The use of the Star "V" or Vanderbilt University name on a project as signage or decoration must be approved in advance by the Project Manager for the Project. The Star "V" is restricted to Athletic Facilities only. The designer in coordination with the Project Manager shall contact the Office of Trademark Licensing and receive written approval of the use of the name Vanderbilt University or the Star "V" Logo.

3.20 Inclusivity and Diversity:

[Vanderbilt University's Non-Discrimination Policy](#) states that "no individual shall be discriminated against on the basis of their race, sex, sexual orientation, gender identity, gender expression, religion, color, national or ethnic origin, age, disability, military service, or genetic information." Based on this policy, these design standards require the full and equal use of all goods, services, facilities, privileges, advantages and accommodations. Vanderbilt University requires that all parties working under the direction of university representatives follow all pertinent laws and codes, the Americans with Disabilities Act, local and state building codes, and the Vanderbilt non-discrimination policy.

3.21 ADA (Americans with Disabilities Act)

VU requires compliance with the Accessibility sections of the Building Code and American with Disabilities Act to be a minimum level of design required for accessibility. Every practical effort shall be made by the A/E firm to improve on this minimum level of accessibility to facilitate barrier-free environments. Please refer to the Vanderbilt Accessibility Masterplan Study (Appendix B) for further details.

3.22 VALUE OF HISTORIC PLACES

Maintain the intended entrance experience of Vanderbilt University historic buildings. Wherever possible, design solutions that use on-grade entrances or low slope ramps integrated into the site to avoid the requirement for railings at abrupt level changes. As an alternative, consider on-grade entrances or down-grade sloping ramps that connect to interior elevators. This may require locating an accessible entrance elsewhere.

SECTION 00 21 00 – INSTRUCTIONS TO DESIGNERS**3.23 PRINCIPLES OF UNIVERSAL DESIGN**

Vanderbilt University is committed to implementing the Principles of Universal Design in all projects. The design of products and environments to be usable by all people, to the greatest extent possible, without adaptation or specialized design.

1. Equitable Use
2. Flexibility in Use
3. Simple and Intuitive Use
4. Perceptible Information
5. Tolerance for Error
6. Low Physical Effort
7. Size and Space for Approach and Use

Expansion on Principles of Universal Design:

https://www.ncsu.edu/ncsu/design/cud/about_ud/udprinciplestext.htm

3.24 CONSIDERATIONS FOR EVERY PROJECT**1. Lactation Rooms**

- a. Vanderbilt University will provide support for breastfeeding mothers as a part of a campus-wide initiative to offer safe and welcome spaces to feed or pump.
- b. Design of new construction Lactation Rooms will follow guidelines set forth by the American Institute of Architects, Lactation Room Design Best Practices. These guidelines will be followed in renovated spaces whenever reasonably possible.

<http://www.aia.org/aiaucmp/groups/secure/documents/pdf/aiap037226.pdf>

2. Gender Inclusive Restrooms

- a. Access to accessible and gender inclusive restrooms are a standard part of new construction projects on campus. Campus Planning strives to place at least one gender inclusive restroom in each new building or major renovation project. Each restroom will contain a lavatory and toilet as well as be designed to be accessible. Where appropriate a shower may be provided to encourage healthy lifestyles.
- b. Gender inclusive restrooms shall be in convenient and easily located areas of the building and grouped with similar spaces.
- c. The signage for gender inclusive restrooms (as with all rooms on campus) shall be with raised letters on a contrasting background placard mounted adjacent to the door typically on the handle side when possible. Paths of travel are as clearly marked as possible and rooms numbered sequentially with thought given to the design of the floor plan in order to make paths of travel as intuitive as possible.

SECTION 00 21 00 – INSTRUCTIONS TO DESIGNERS

3. Signage and Wayfinding

- a. Project Manager will coordinate wayfinding according to the most recent campus standards.
 - i. Align coordinates with the campus plan that includes Physical signage, mobile applications, and digital displays.
 - ii. Ensure that wayfinding is accessible to those with sight impairments by including braille on wayfinding signage.

4. Sustainability, Accessibility, Landscape, and Mobility Requirements

- a. Concepts, strategies, and requirements laid out in Appendices A through D must be incorporated into each project.

3.25 FM Global

- **FM Global** – the University has partnered with FM Global to further improve the design and safety of our buildings. As such a few new requirements will be made of our systems, generally the changes effect the plans review by FM Global, fire suppression through the building sprinkler system, thermal and moisture protection, size of gas service, transformers selection, fire alarms and preferred location for some building equipment.

3.26 Plan Review and Submittal

- In addition to the plan review by Facilities the designer should plan on submitting a full set of construction drawings and specifications to the FM Global Atlanta Operations office for review and acceptance prior to beginning work. Provide submittals to FM Global Atlanta Operations at:

FM Global Insurance Company
Preston Ridge III
3460 Preston Ridge Road, Suite 400
Alpharetta, GA 30005

P: (770) 777-3600 ext 3084 **F:** (770) 777-0414
email: ENGAtlantaPlanReview@fmglobal.com

Please include the following information with each submittal:

Client Name: Vanderbilt University
FM Index No.: 00133.67-01
Account No.: 01-19016
Project Name:
Vanderbilt Campus Planning Project Engineer/Architect:

3.27 BUILDING SPACE ORGANIZATION

1. Ensure new drainage systems are designed to convey the 100-year rainfall-induced site runoff without causing property damage. The duration of the design 100-year rainfall is selected to maximize site runoff. Both subsurface routing (drainage piping) and overflow can be used to direct the runoff.
2. Do not locate critical rooms with important/valuable equipment, furnishings, storage or supplies in below grade areas, basements, or in areas subject to flooding or surface water build-up. If items such as these must be in areas prone to flood or surface water inundation, locate the items at least 2 ft.

above the projected 500-year flood level or the expected surface water level.

3. Water leakage can cause severe damage to facilities with finished interiors. Please refer to FM Global Property Loss Prevention Data Sheet 1-24, *Protection Against Liquid Damage*, for guidance regarding critical room exposure, emergency response, inspection, testing, and maintenance of equipment and piping.
4. Provide FM Approved leak detection systems with alarm notification at a constantly attended location for critical rooms, high value equipment areas, and for rooms areas where domestic water and fire protection services enter the buildings or are adjacent to or above critical room areas.

-END OF SECTION –

SECTION 00 21 02 - PROJECT MANUAL GUIDELINES**INTRODUCTION**

These instructions are intended to guide the Architect in preparing the Project Manual for Vanderbilt University projects. Text in italics provides direct instructions to the Architect. Text in regular type is intended to be copied directly into a specification section. The instructions are organized by specification section and are to be used as a checklist to ensure the minimum sections required by Vanderbilt University are included in the Project Manual. . The Architect and project team should use an integrated design process to develop a plan and design that adheres to academic goals and sustainable design principles, looking comprehensively at climate impact, use, building design, and systems, while adhering to timeline and budgetary constraints. For more details, refer to the SBS (Appendix A).

SECTION 00 25 13 PRE-BID MEETINGS

Work with the Vanderbilt Project Manager to schedule the pre-bid meeting(s) so that the Bidders have sufficient time to examine the drawings before the meeting and have several days to ask questions after the meeting. Schedule a firm deadline for submittal of questions from the Bidders. After the question submittal period ends, schedule sufficient time to prepare and issue the final addendum. Allow the Bidders sufficient time to fully incorporate the addendum pricing into their bids before bids are due. All questions received from the Bidders, and answers to these questions are to be included into the addendum.

Include the following text in your specification section:

The pre-bid meeting shall be include with the following as the minimum agenda:

1. Confirm that bidders have a full bid package including any addenda issued to date.
2. Review the timetable for submitting questions and issuing addenda.
3. Confirm the bid date and time.
4. Advise that no changes to the Contract Documents are binding unless included in an addendum. State that all questions and answers will be issued as part of the next addenda.
5. Review the project scope and schedule. Have the A/E team describe the main concepts of the project.
6. Describe any particular difficulties related to this project.
7. Tour the site and existing conditions.
8. Have a question and answer session.

SECTION 00 31 00 AVAILABLE PROJECT INFORMATION

Construction Schedules – Include in this section the requirement that the Contractor include a construction schedule in all bid packages distributed to Subcontractors.

Other Project Information – Include in this section the requirement that the Contractor make available to all Subcontractors all relevant project information including existing condition information, site surveys, environmental assessment information, existing material information, existing hazardous material information, geophysical data, and geotechnical data or other surveys which were performed in the course of the design process. Provide copies of this information to the Contractor. Ask the Vanderbilt Project Manager for copies of all project information that was generated by the Owner.

SECTION 00 21 02 - PROJECT MANUAL GUIDELINES**SECTION 00 41 00 BID FORMS**

Require the Contractor to include the following text on the Bid Forms issued by the Contractor to all Subcontractors:

CHANGE ORDER RATES

In order to establish the amount of a change in the Cost of the Work, state the following information on your submitted bid form. Costs shall apply to deductive change orders as well as additive change orders.

1. Labor Rates – List Rates for each category of worker to be itemized, for example, laborer, tradesman, journeyman, foreman, etc. Rates shall include wages and labor burden as defined in Section 00 73 01.
2. Equipment Rental Rates – Show net rental rates as a percentage discount or premium of the published AED rental rates.
3. Overhead and Profit – List separately the percentage rate for (1) overhead for labor and materials as defined in Section 00 73 01, (2) profit for labor and materials, (3) overhead for subcontracted work, and (4) profit for subcontracted work.
4. Other Charges – List any other proposed costs to be charged either as a percentage, unit price, or as a lump sum.

SECTION 00 60 00 PROJECT FORMS

Use the Vanderbilt University Standard Specification Section.

SECTION 00 72 00 GENERAL CONDITIONS

Include the latest version of the VANDERBILT UNIVERSITY STANDARD AIA A201 – 2007 in the Project Manual.

SECTION 00 73 00.01 CONTRACTOR'S GENERAL CONDITIONS COSTS

Use the Vanderbilt University Standard Specification Section.

SECTION 00 73 00.02 CONTRACTOR'S SELF-PERFORMED WORK

Use the Vanderbilt University Standard Specification Section.

SECTION 00 73 00.03 TAX SAVINGS PROCEDURES

Use the Vanderbilt University Standard Specification Section.

SECTION 00 91 13 ADDENDA

Addenda should be issued by the A/E team during the bidding, when a sufficient number of questions from the Contractor and Subcontracts have been collected, or important issues that affect the Cost of the Work have been discovered..

The use of addenda to complete an otherwise incomplete or poorly coordinated set of bid documents is considered by Vanderbilt University as a failure on the part of the design team to fulfill their obligation to complete the Contract Documents as required by contract. Please see section 3.4.1 of your contract.

SECTION 00 21 02 - PROJECT MANUAL GUIDELINES**SECTION 01 14 00 WORK RESTRICTIONS**

Many projects at Vanderbilt University have restrictions that will affect construction operations. These include limited physical access to the project site; partial occupation of buildings under construction; surrounding buildings that are in use; pedestrian and vehicle traffic near the project site; and other restrictions due to the nature of construction on an urban university campus.

Include in this section project-specific instructions to the Contractor regarding restrictions of construction hours, noise restrictions, restrictions due to partial occupation of the building, or other restrictions, if any.

In general, normal construction hours can be observed on many projects, however noisy construction work near occupied residence halls cannot start before 9:00am.

No construction activity shall take place on Commencement Day, which is held in mid-May each year.

Check with the Project Manager for a determination of specific restrictions for your project.

Specify noise design standards inside and outside the building

- a. Use ASHRAE handbook design guideline for background HVAC sounds in room.
- b. Outside use 55 (or less) dBA for any noise that reaches ground level

SECTION 01 21 00 ALLOWANCES

The use of allowances in Contract Documents shall be avoided wherever possible. Excessive use of allowances is viewed by Vanderbilt University as a failure on the part of the design team to fulfill their obligation to fully complete the Contract Documents as required by contract.

Prior approval is needed from the Vanderbilt project manager before including allowances in the Contract Documents. Approval will only be granted in unusual cases where selections or specifications are not available to the design team at the time of issue of the Construction Documents.

SECTION 01 22 00 UNIT PRICES

The use of unit prices in Contract Documents shall be avoided wherever possible and should be used only in the case where Vanderbilt University desires to maintain flexibility to change the quantities of specific portions of work.

Prior approval is needed from the Project Manager before including unit prices in the Contract Documents.

SECTION 01 29 00 PAYMENT PROCEDURES

Use the Vanderbilt University Standard Specification Section. As part of the Pay Application review process, the designer shall certify that the Record Drawing mark-ups have been updated by the Contractor through the current pay period.

SECTION 01 31 13.01 UTILITY OUTAGE REQUESTS

Use the Vanderbilt University Standard Specification Section.

SECTION 01 32 00 CONSTRUCTION PROGRESS DOCUMENTATION

Require the Contractor to submit a two-week look-ahead schedule at every progress meeting.

SECTION 01 35 23.01 CONTRACTOR'S SAFETY PROGRAM

Use the Vanderbilt University Standard Specification Section.

SECTION 00 21 02 - PROJECT MANUAL GUIDELINES**SECTION 01 51 00 TEMPORARY UTILITIES**

Most areas of the campus are served by Vanderbilt utilities. However, in some areas, electrical power is only available from NES. Include in this section the following text:

When available at the project site, the Owner shall provide to the Contractor electrical power, telephone, internet service, steam, and chilled water at no cost to the Contractor. If not available from the Owner, the Contractor shall be responsible for obtaining these utilities from local providers. Costs for temporary utilities necessary for completion of the Work shall be part of the Cost of the Work to the extent that these charges are not provided for, or directly billed to the Owner.

SECTION 01 51 26 TEMPORARY LIGHTING

Include in this section requirements for lighting the project perimeter construction fence to an average level of 0.5 foot candles.

SECTION 01 78 23 OPERATIONS AND MAINTENANCE DATA

Use the Vanderbilt University Standard Specification Section.

SECTION 01 78 39 PROJECT RECORD DOCUMENTS

Use the Vanderbilt University Standard Specification Section.

SECTION 01 79 00 DEMONSTRATION AND TRAINING

Use the Vanderbilt University Standard Specification Section.

SECTION 02 41 13 SELECTIVE SITE DEMOLITION

Use the Vanderbilt University Standard Specification Section.

SECTION 21 13 00 FIRE-SUPPRESSION SPRINKLER SYSTEMS

Include requirements that the Contractor use a sprinkler system Red Tag Permit when any portion of the sprinkler system is taken out of service during construction. These permits can be obtained through the Project Manager. An example of this permit is located in Section 00 60 00 Project Forms.

SECTION 31 11 00 CLEARING AND GRUBBING

Use the Vanderbilt University Standard Specification Section.

SECTION 31 22 19.13 SPREADING AND GRADING TOPSOIL

Use the Vanderbilt University Standard Specification Section.

SECTION 31 23 00 EXCAVATION AND FILL

Use the Vanderbilt University Standard Specification Section.

SECTION 31 25 13 EROSION CONTROL

Use the Vanderbilt University Standard Specification Section.

SECTION 32 01 90.33 TREE AND SHRUB PRESERVATION

Use the Vanderbilt University Standard Specification Section.

SECTION 32 11 23 AGGREGATE BASE COURSES

Use the Vanderbilt University Standard Specification Section.

SECTION 00 21 02 - PROJECT MANUAL GUIDELINES

SECTION 32 12 16 ASPHALT PAVING

Use the Vanderbilt University Standard Specification Section.

SECTION 32 13 13 CONCRETE PAVING

Use the Vanderbilt University Standard Specification Section.

SECTION 32 17 23 PAVEMENT MARKINGS

Use the Vanderbilt University Standard Specification Section.

SECTION 32 80 00 IRRIGATION

Use the Vanderbilt University Standard Specification Section.

SECTION 32 90 00 PLANTING

Use the Vanderbilt University Standard Specification Section.

-END OF SECTION -

SECTION 00 80 00 - DESIGN CONCEPTS**Part 1 – General****1.01 Scope**

The intention of this section to identify important elements of the University for finished products.

Part 2 – Products**Part 3 – Execution****3.01 Sound Transmission**

1. Sound levels for all indoor and outdoor spaces shall comply with ASHRAE NC Levels.

3.02 Screening of Rooftop Equipment and Building Penetrations:

1. Mechanical and Electrical equipment shall be suitably screened from the ground level. Review proposed solution with the Project Manager.

3.03 LEED Certification

1. As standard practice the University follows many of the design guidelines suggested by USGBC including waste recycling, VOC limitations, water efficiency practices, reduced heat island efforts, optimizing energy performance, HVAC commissioning, air quality monitoring, etc.
2. Each project falls under one of four tiers, as outlined in the SBS (Appendix A). Tier 1 and 2 projects, which include new construction, major additions, large-scale renovations, and partial building interior fit-outs for HVAC, lighting and materials will require LEED certification as well as potentially other certifications as outlined in the SBS.
3. In addition to certifications, teams are to use energy modeling to determine energy savings to meet an initial goal of 50% below ASHRAE 90.1-2016 and to meet EUI targets outlined in the SBS.

3.04 Building Envelope Design**Part 1 – General**

1. Typical exterior windows shall be double-paned, thermally broken with a maximum U value of 0.38 for the assembly or the most current code requirement.
2. SHGC maximum value of 0.4. Lower values are good for reducing air conditioning load. The SHGC should not exceed 0.25 for west facing windows.
3. The Visible Light Transmittance (VT) should be at least 1.10 times the SHGC. This number should not exceed 60% VT as excessive glare will result
4. Additional building envelope design criteria and strategies are included in the SBS (Appendix A).
5. Envelope testing for windows, walls, roofs and ventilated MER's is required.

SECTION 00 80 00 - DESIGN CONCEPTS**3.05 Restroom Design**

1. Special attention shall be given to the design of shower stalls and waterproofing of floors and walls in restrooms and janitor's closets. The design shall be reviewed carefully with the Project Manager and is particularly important in residence hall projects.

3.06 Lighting Design

1. Vanderbilt, in an on-going effort to reduce energy consumption, requires projects to develop a lighting plan that is energy efficient and makes maximum use of daylighting and other strategies to lower building lighting energy requirements. Please refer to the MEP section of these standards and to the SBS (Appendix A) for more information on specifications and sustainability strategies.
2. Where appropriate the use of ceiling mounted occupancy sensors in ACT applications and wall mounted in a drywall ceiling application is recommended.
3. The different types of lamps selected should be kept to a minimum and reviewed with the Project Manager.
4. Do not specify incandescent lighting.

3.07 Mechanical Design

1. Mechanical equipment (fans, VAV boxes) must be accessible and not located above gypsum board ceilings.
2. Filters should be of a standard size and easily accessible for replacement.
3. Consideration should be given for access to mechanical equipment and adequate working clearances as well as removal of equipment at a future date..
4. Provide shut off valves for plumbing at each floor or for each new renovation.

3.08 Building and Site Signage**Part 1 – General**

1. New and/or replacement exterior signage on buildings or site shall be reviewed and approved by the project manager for each project.
2. Exterior building signage should be kept to a minimum and located only at the major entry point into a building.
3. Site signage shall also be kept to a minimum. Site signage indicating a building name is not necessary and is discouraged once on the campus.
4. Site sign shall be low, metal blade type, and located only where a building may be approached from along a street. This allows a driver to confirm the destination, before proceeding to a parking area.

END OF SECTION -

SECTION 00 90 00 - ADDENDA & MODIFICATIONS

Part 1 – General**Part 2 – Products****Part 3 – Execution****3.01 Addenda**

After distribution of Contract Documents but PRIOR to receipt of bids, the Designer shall employ Addenda to modify drawings and specifications. If receipt of bids is imminent, the Designer shall consult the Construction Manager (CM) and/or the Project Manager to determine method of altering Contract Documents. Addenda shall not be used after receipt of bids. For changes which simultaneously effect portions of work for which (1) bids have been received and (2) bids have not been received, the Designer will consult with the Project Manager to determine whether Addenda or Request for Proposal (RFP) shall be used.

3.02 Evaluations

After receipt of bids, the Designer shall employ RFP's to modify Contract Documents. RFP's shall be numbered sequentially throughout the course of contract administration. Drawings attached to and incorporated in RFP's shall also be numbered sequentially following the prefix "SK". "SK" drawings can be hand drawn sketches, but should be of a high enough quality to be incorporated into the Contract Documents. Unless drawing revisions referenced in RFP's necessitate the redrawing of entire sheets(s) of Contract Document drawing(s), "SK" drawings should be submitted on 8 1/2" x 11" or 11" x 17" format, so that they may be easily reproduced and distributed to trade contractors by CM. SK drawings should be generated on the native files and be used as part of the record documents.

3.03 Evaluation Log

The Designer shall require, in Section 00 90 00 of Project Specifications, the CM to maintain an RFP Log. This Log will be used for the purpose of tracking proposed changes. From the start of the project, the Log shall list proposed changes in order by number, date, description, cost, source of funding, disposition (action & date), and Change Order Reference Number. The RFP Log, encompassing the disposition of specific RFP's, will form the basis of Change Orders to the Contract Documents.

3.04 Tracking of Modifications

The Designer shall require, in Section 00 90 00 of Project Specifications, the CM to collate and maintain sets of all Addenda, RFP's, and other forms of modification to Contract Documents with all required Contract Document sets.

-END OF SECTION -

SECTION 00 95 00 - AIR QUALITY PERMITTING**Part 1 - General****1.01 Scope**

1. Designer shall supply a list of all potential air emissions sources to the Owner's Project Manager during the design development phase of the project. Owner shall obtain all required air permits for new emissions sources.
2. The list shall include all building exhausts (except restroom exhausts), vents and stacks associated with the project including those from fuel burning equipment (boilers, generators, etc.), systems/equipment which generate air emissions (paint spray booths, sterilizers, dry cleaners, etc.), and vapor/fume collection systems, which vent to atmosphere (laboratory hoods, etc.). Designer should include on the list any devices, equipment, or operations for which there is any uncertainty as to the requirement for inclusion in the permitting process.
3. The information provided to the Owner's Project Manager shall then be turned over to Plant Operations' Director of Buildings and Utilities who shall be responsible for contacting Vanderbilt's Air Quality Permit Consultant as to the nature and type of proposed equipment. The consultant shall prepare the appropriate documents required by the Metropolitan Health Department, Division of Pollution Control for modification to our Title V Operating Permit and permit to construct new stationary air pollution sources.
4. During the construction document phase of the project, the Designer shall provide the Owner's permitting consultant with all necessary information, as requested by the permitting consultant, to complete applications for air permits.

Part 2 – Products**Part 3 - Execution**

END OF SECTION -

SECTION 01 06 70 - HANDICAPPED ACCESSIBILITY**Part 1 - General****1.01 Scope:**

Vanderbilt University's Equal Opportunity, Affirmative Action, and Disability Services (ESD) Office and Accessibility Task Force have developed recommendations for greater campus accessibility, based in part on the 2010 Standards

For Accessible Design. Recommendations are designed to meet the specific needs of persons with disabilities on this campus. Because the American National Standards Institute's set of standards, ANSI A117.1, comes very close to meeting those needs. ANSI 117.1 has been adopted as the University's standards with these additional recommendations. **THESE GUIDELINES DO NOT ALLEVIATE THE DESIGNER FROM COMPLIANCE WITH OTHER GOVERNING CODES.**

These Accessibility Recommendations can be reviewed in detail in the Accessibility Master Plan (Appendix B). These should be reviewed and included in all new construction and renovation plans. In the event that one of the recommendations cannot be met or needs to be modified or changed to be met, a written explanation (which specifies the recommendation and the difficulty meeting it) must be submitted through the Project Manager to appropriate channels for approval prior to any work on the project taking place.

1.02 Additional Guidelines for Vanderbilt University

1. Accessible Route
 - a. The minimum width has been increased from 36 to 45 inches with 60 inches preferred.
 - b. The heights of the sides of walkways and adjacent surfaces are not to vary in level more than 1 inch. If there is a variance beyond 1 inch, curbs or railings are to be provided as protection.
2. Parking Spaces and Passenger Loading Zones
 - a. It is preferred that a passenger loading zone be provided.
 - b. Measures should be taken to prohibit blockage of the access aisle/passenger loading zone by unauthorized vehicles.
3. Curb Ramps
 - a. Curb ramps with widths between 36 and 48 inches shall be flared with the maximum flare slope 1:12 and maximum counter slope of 1:20. For curb ramps with widths greater than 48 inches, a returned curb design is allowed, with care taken to minimize tripping hazards.
4. Ramps
 - a. It is preferred that all ramps have a minimum width of 45 inches. Further, the ADA requires that there shall be a flat, unobstructed area, minimum 5' x 5', at the bottom and top of the ramp to allow for adequate turning radius.

SECTION 01 06 70 - HANDICAPPED ACCESSIBILITY

5. Elevators

- a. Consideration should be given to ensure functional use of elevators by individuals with different handicaps, i.e., physical, hearing, and visual.

6. Doors

- a. All doors to public spaces should be 36" in width and shall provide a minimum of 32" clear opening with the door open to 90 degrees.
- b. Special consideration should be given to assure an adequate turning radius in all situations where two doors are in a series or doors enter a space immediately requiring a 90 degree turn, situations which occur frequently in entry foyers and bathroom privacy screens.
- c. The force to open all doors (exterior or interior) is not to exceed 5 lbs.
- d. It is recommended that all exterior doors and those doors subdividing major building corridors have 7-1/2 inch minimum kick plate at the bottom of the door.
- e. It is highly preferred that at least one accessible entrance is equipped with an automatic door as per University specifications.

7. Toilet Stalls

- a. Of ANSI's toilet stall designs, two are preferred. The first approved ANSI design is the design which utilizes two side grab bars and has dimensions of 66 inches (deep) by 36 inches (wide). The second utilizes one back grab bar and one side grab and has dimensions of 56 inches (deep) by 60 inches (wide).
- b. All toilet accessories including towel and soap dispensers must fall within the permissible reach limits (15-48 inches) and have clear floor spaces to allow approach.

8. Alarms

- a. Where alarm systems are provided, the capability for future extension of the visual alarm system to selected areas should be provided. For example, a residence hall room or office assigned to a hearing-impaired person should have the capability of providing a visual alarm in that space.
- b. Fire alarms must be within the reach limitations of a person in a wheelchair.

9. Signage

- a. It is required that accessible toilets, phones, and other user facilities be clearly marked using the international symbol of accessibility.

10. Telephones

- a. It is preferred that all operable parts of a telephone are no more than 45 inches high.

SECTION 01 06 70 - HANDICAPPED ACCESSIBILITY

11. Classrooms

- a. Teaching oriented facilities must provide at least one accessible work station (Reference ANSI Computer Table and Desk Standards).
- b. All control height and approach standards shall be met.

12. Recreational Equipment

- a. In the event that a facility contains recreational equipment, every effort is to be made to make all equipment accessible.
- b. In the event that a facility contains a pool, a lift facilitating access to people in wheelchairs is to be provided.

Part 2 – Products

Part 3 - Execution

-END OF SECTION -

SECTION 01 14 19 - CONTRACTOR USE OF PREMISES**Part 1 – General****Part 2 – Products****Part 3 – Execution****3.01 Site Use Map**

1. The Contract Documents must include a Site Use Map with area layout along with all necessary diagrams to delimit and locate staging for construction material storage, trailers, on-site contractor(s) parking with access and non-access routes noted, do-not-disturb areas, priority vegetation, topsoil storage, and any other site considerations. Project limits must be clearly designated on site plans. Plans are to be reviewed by the Project Manager for determination as to temporary site lighting and fencing requirements. These should be noted when possible onsite plan. The Designer will review all items jointly with the Project Manager and the Construction Manager.
2. This site plan must be approved by Vanderbilt Traffic and Parking and Plant Operations as well as various Metro Davidson County agencies (such as codes, Metro Police Department for street closures) prior to any work commencing on site.

3.02 Protection to Streets, Walks, Lawns, Vegetation, Drainage/Irrigation Systems, Etc

Contract Documents must include Specifications that will ensure that access routes to and from the project, and the project premises are protected from mud, sand, stone, litter, and debris of any form, and that this protection be made the responsibility of the Contractor(s). All damage and temporary soiling of an area or misuse of property within, or exterior to, a construction site in variance with agreed upon terms shall be corrected time wise and to approximate the original condition to the satisfaction of Vanderbilt. Corrective measures that must be taken by outside parties at Vanderbilt's direction upon failure of Contractor(s) to make the mutually agreed upon corrections will be the financial responsibility of the Contractor(s).

3.03 Employee Conduct

1. Construction personnel are to adhere to, and contract documents must include, the following:

"At any time during construction of a project on Vanderbilt University property, if the conduct of any worker is judged by the Owner, Contractor, Architect, or Engineer to be of nuisance to the Owner, or a worker be considered incompetent or detrimental to the work, the Contractor shall order such parties removed immediately from the grounds; whistling at and directing attention getting related noises towards any campus occupant are grounds for such removal."
2. No dialogue is to occur between workers and campus occupants. Use of campus facilities (toilets, telephones, interior premises, etc.) or grounds elements, i.e., benches, dumpsters, containers, etc., by construction-related workers is prohibited unless terms are specifically agreed upon otherwise.
3. All contractors to have visible identification.

SECTION 01 14 19 - CONTRACTOR USE OF PREMISES**3.04 Noise and Scheduling of Construction Activity**

Efforts must be explored to minimize all Construction related noise, particularly when near residence halls and classrooms. Daily site activity may begin at 7:00 a.m. but loud, repetitive noise (jackhammers, backhoes, etc.) should not start prior to 9:00 a.m., or as agreed. Construction activity is discouraged on weekends. Construction activity is prohibited on Commencement Day and is limited during three annual Board of Trust visitations (February, April and November) and the day before Commencement. Additionally, noisy work during end of semester exams is discouraged. These dates are to be identified through Project Manager.

3.05 Waste Disposal and Recycling

On all large renovation or new construction projects, contractors are responsible for providing their own dumpsters and disposing of all waste materials. The Contractor is encouraged to recycle materials, where feasible and use a waste hauler who processes comingled waste. The scale of some projects will be sufficiently small to (1) suggest possible savings or (2) minimize the impact of construction on the surrounding campus by utilizing university-supplied dumpsters. On these smaller projects, the Contractor will request permission from the university Project Manager to utilize university dumpster(s). When granted this permission, the Contractor will recycle cardboard, aluminum and white paper in the same manner as university personnel; moreover, these items will be taken to university recycling collection centers by the contractor. The university Project Manager will instruct the Contractor on the locations of the university recycling centers. For all projects, contractors are responsible for handling all waste materials according to Vanderbilt's SBS (Appendix A).

3.06 Maintaining Daily Campus Activities

Care must be taken to maintain or to designate rerouting of primary pedestrian circulation channels around the construction site limits and related barriers. Barriers are to display appropriate signage conveying detour routes. Site lighting should illuminate peripheral areas adequately for safe pedestrian passage along detours at night.

3.07 Key Access to Facilities

The Project Manager will coordinate temporary construction keying and all related issues of access and building security into a facility during construction. Card access will be permitted on a case by case basis. See attached Commodore Card office form for card access to buildings for non- Vanderbilt employees. This form is to be filled out by the Project Manager on a case by case basis. Additionally keys may be obtained through the Key Shop on a case by case basis.

3.08 Open Flame Permit

A permit for cutting and welding with portable gas on ARC equipment shall be filed two days before starting work. The form may be obtained from the Campus Planning website, and must be filed at the job site. See A/E Standards Section 01 35 13.

3.09 Smoking Policy

Smoking or the use of tobacco products is prohibited on all Vanderbilt jobsites.

SECTION 01 14 19 - CONTRACTOR USE OF PREMISES

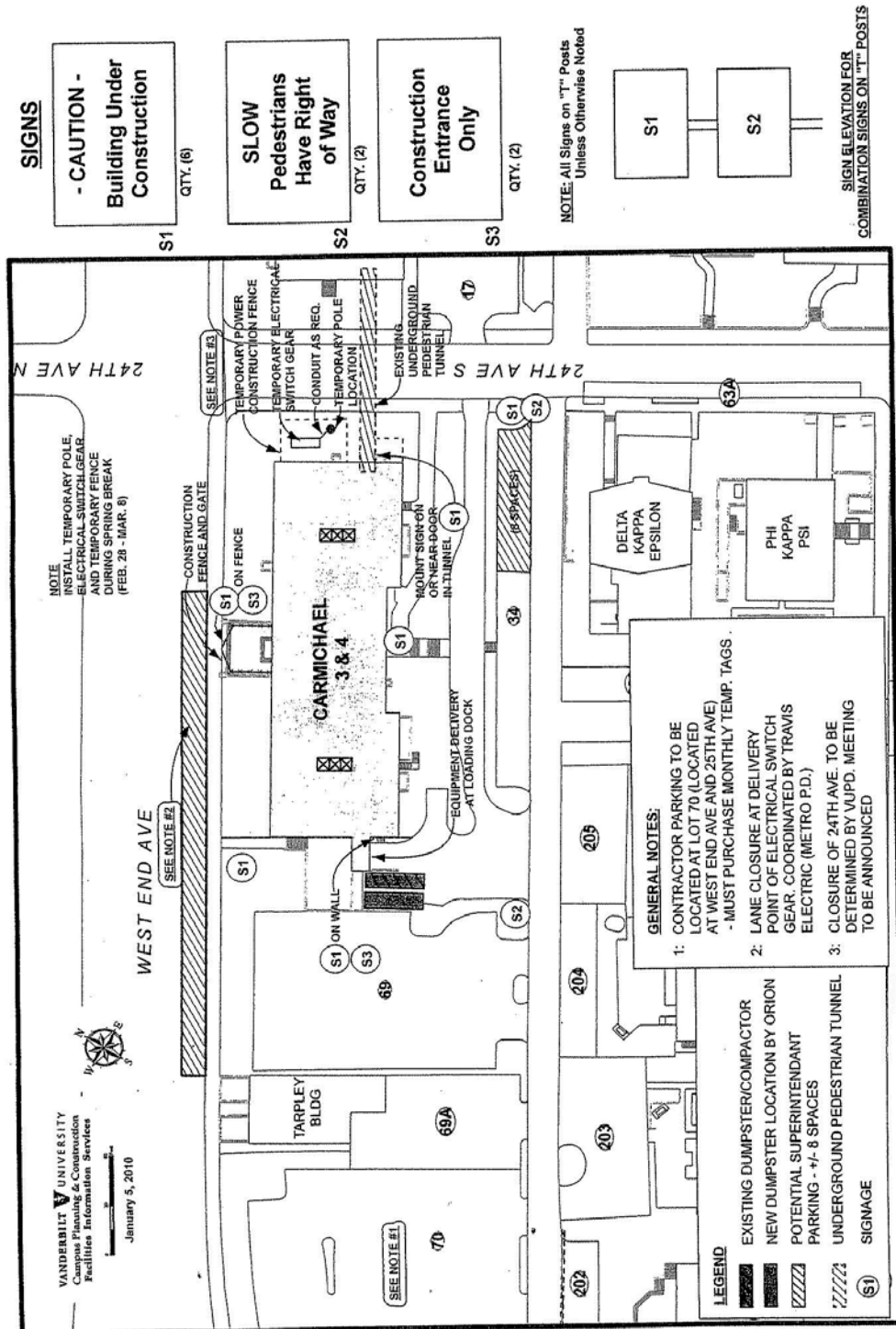

SECTION 01 14 19 - CONTRACTOR USE OF PREMISES

Construction & Scheduled Maintenance Parking Requests

--Plant Operations and Campus Planning Projects--

This policy does not apply to emergency maintenance projects. Plant Operations and Campus Planning must contact the Office of Traffic & Parking as soon as possible when last minute or emergency maintenance is being conducted; parking arrangements will be made on a case-by-case basis.

CONSTRUCTION & SCHEDULED MAINTENANCE PARKING POLICIES

- All request forms should be submitted 72 hours in advance to allow for proper notification and posting.
- Parking inside designated Construction areas (inside Construction Fences) are controlled by the construction supervisor.
- All requests for parking must be submitted online through the [Special Event Request Form](#) (*Please print a copy for your records*).
- Requests are not approved until confirmed by Vanderbilt University Office of Traffic and Parking in writing.
- Incomplete requests cannot be processed.

All Vendors and Construction workers parking on the Vanderbilt campus must purchase **Vendor** permits. These permits are available for one day, one week, one month, 3 months, or for a year. Permits are valid in non-reserved spaces in Zone lots, loading docks (while loading and unloading **ONLY**), or as designated on the permit. Vendor permits are *not* valid in Lot 95 or 96.

Vehicle parking or standing is prohibited on campus in areas not specifically designated for parking. Parking areas within the University complex are clearly marked. **Any area not lined as a space or designated with a parking sign is a NO PARKING area.** Parking is not allowed on sidewalks, lawns, or on patios without specific written approval.

PRICING POLICY

When requests are received at least three business days before needed:

- Reserved Spaces/Lots requiring signs or requiring that spaces be vacated:
 - **\$5.00 daily per space**

When received less than least three business days before needed:

- Reserved Spaces/Lots requiring signs or requiring that spaces be vacated:
 - **\$10.00 daily per space** (when the request is received 2 business days before the event begins)
 - **\$15.00 daily per space** (when the request is received the business day before the event begins)



[Special Event Parking Request Form](#)

Please complete this form to secure authorization for events which will require special traffic or parking services. Form can be found at www.vanderbilt.edu/parking (click on **Event Parking Request** on the left hand side of the page).

- END OF SECTION -

SECTION 01 15 00 - SITE UTILITY PROTOCOL**PURPOSE:**

Unplanned interruption of existing underground utilities poses significant risk to the owner, contractor, facilities plant operations, and utility consumers during new construction. The purpose of the Existing Facilities Protection Plan is to provide guidance and consistency with regard to the application of quality assurance and control measures applied on the Vanderbilt University (VU) and to avoid unnecessary financial burden, delays in construction schedule, and/or unplanned interruption of existing services to VU facilities plant operations, students, faculty, and staff. This plan is intended to provide a very specific action plan that the Construction Manager can use to lead quality throughout the pre-construction and construction processes of this project, to mitigate the risk of unplanned interruption of existing utilities and to document existing and/or new underground utilities. In detail, the Existing Facilities Protection Plan addresses pre-task planning prior to the start of work activity and explains how existing utilities will be located, tracked, and protected during construction. The plan also identifies the document control and communication process to be implemented when undocumented utilities are encountered, existing utilities are relocated, and/or new utilities are put in place.

PART 1 – PRE-TASK PLANNING

The Construction Manager shall perform a Pre-Construction Meeting (Preparatory Meeting) on site with subcontractors immediately prior to the start of work. At this time the subcontractor's work scope, existing site conditions, site logistics, site safety, project plans and specifications, and quality controls are reviewed with the subcontractor foreman leading the work. Prior to commencement of site utilities work or work requiring excavation, trenching, installation, relocation of existing services, etc. the following actions are required.

1.1 UTILITIES NOTIFICATION (REFERENCE SECTION: 01 41 17 UTILITY NOTIFICATION)

A. Contractors must notify "TNOCS" by telephone before performing any earth moving operations including digging, trenching, boring, site demolition, excavation, backfilling, or grading in all public ways and private property.

B. This notification must be made at least 72-hours (excluding weekends and holidays) prior to the work described above, but not more than 10 calendar days before commencement of the contemplated work. The toll free number is 811 or 1-800-351-1111.

C. Member utilities of the Utilities Underground Plant Damage Prevention System are required to respond to the notice within 72 hours from the time said notice is received by designating at the locus the location of pipes, mains, wires, or conduits.

1.2 CONTRACTOR DIG PERMIT (SECTION: 00 73 19 M MCC HEALTH AND SAFETY)

A completed dig permit must be submitted prior to start of work which calls for penetrating the soil either by digging methods or driving stakes into the ground more than two inches. Forms must be completed in detail and can be completed by hand.

PART 2 – UTILITY LOCATING

At the start of construction work, utility locations marked on site by TN ONE CALL and/or VU ONE CALL shall be compared to the project construction drawings and the Vanderbilt University Campus Planning and Construction (CPC) GIS drawings, all differences shall be brought to the owner attention.

SECTION 01 15 00 - SITE UTILITY PROTOCOL**2.1 LOCATING EXISTING UTILITIES**

A. Private utilities shall be marked on site by Underground Locators (JONATHAN PEMERTON) and public utilities will be marked on site by TN ONE CALL locators in areas shown to be disturbed by new work associated with the project.

B. Locations of underground utilities shall be marked by spray paint or stakes. Marks will be color coded with additional descriptions of letters and arrows as required.

C. Contractors are not to commence work until "TNOCS" has been properly notified and has responded as described in Section 1.1 above.

2.2 TRACKING EXISTING UTILITIES

A. Following the pre-construction meeting the Construction Manager and its subcontractors will review the markings on site in comparison to the project construction documents and the VU CPC GIS drawings to verify existing conditions as reflected by the locators' markings reflect the existing conditions as shown on construction and VU plans.

B. The contractor is fully responsible for tracking, protecting, and maintaining utility location markings. Maintenance of the existing markings will be re-painted by the contractor and/or staked for future reference and use.

C. Subcontractors are required to review changes in conditions on a daily basis and report new information, identify hazards, and communicate current planned activities. Any unforeseen conditions shall be reported immediately to the Construction Manager.

D. During Weekly Subcontractor Coordination and Progress Meetings subcontractors provide updates on existing conditions, progress of planned work, and communicate and/or identify utilities that have been modified and/or abandoned.

2.3 PROTECTING EXISTING UTILITIES AND TREES

A. Contractor shall perform work in such a manner, and with reasonable precautions taken to avoid damage to utilities under the surface in said areas of work. Immediately notify any known or suspected damage to underground utilities to the owner of such utilities.

B. Prior to the start of excavation and/or trenching work the Construction Manager shall coordinate a landscaping pre-construction meeting with the subcontractor performing the work and Vanderbilt's Landscape Architect to review planned excavations and VU requirements for tree protection.

C. Excavation adjacent to existing utilities must be performed with caution. Existing utilities shall be protected as required and hand excavation must be utilized when new excavations or trenching encroach upon existing utilities that have been marked by underground locators.

D. Existing utilities required to be relocated for the installation of new work shall be coordinated with the Construction Manager prior to installation of additional work.

SECTION 01 15 00 - SITE UTILITY PROTOCOL**PART 3 – DOCUMENT CONTROL AND COMMUNICATION**

The following document control and communication process shall be implemented when undocumented utilities are encountered, existing utilities are relocated, and/or new utilities are put in place. This process will ensure all necessary parties are informed of existing conditions, changes required for new work, and updates or modifications to existing plans.

The Construction Manager shall not assume any utility that is not marked is abandoned. All Utilities shall be confirmed to be either active or not prior to removal or modification.

3.1 UNDOCUMENTED/UNFORESEEN CONDITIONS AND VARIANCES FROM PLANS

A. When undocumented or unforeseen conditions arise the contractor shall notify the owner of the utility, the designer of record, and Vanderbilt CPC.

B. The Construction Manager shall document the "issue" providing corresponding photos, drawing references, and documentation as required to request additional information from the designer of record. The report will be attached to a formal Request for Information (RFI) for review and response by the owner, designer, and construction team.

3.2 UTILITY RELOCATION, ABANDONED UTILITIES, AND AS-BUILT CONDITIONS

A. The Construction Manager will keep a working copy of construction as-built drawings. Subcontractors shall provide updated information on a weekly basis for new utility locations, changes in existing conditions, and identify utilities that have been modified and/or abandoned. The Construction Manager shall also make field observations and report as-built records or modify existing construction plans to reflect existing conditions.

B. The Construction Manager will document changes in the underground utilities plans as work progresses and provide VU CPC regular updates to coordinate with timely revisions to the VU CPC GIS mapping drawings.

C. Require 3D as-built drawings or models, based on state plan coordinates, for all underground utilities.

END OF SECTION -

SECTION 01 91 00 - COMMISSIONING

01 GENERAL

1.1 DESCRIPTION

Commissioning: Commissioning is a systematic process that helps ensure that all building systems perform interactively in accordance with the design intent and the owner's operational needs. This is achieved by implementing commissioning procedures at the project's inception, starting by generating an Owner's Project Requirements document that all design and construction activities must support; continuing through the project's design phase; by documenting the design intent; and by continuing the commissioning procedures throughout the construction, acceptance, and warranty phases, conducting actual equipment / system performance verification. The commissioning process shall encompass, coordinate and / or help oversee the traditionally separate functions of: system documentation; equipment start up/checkout; control system calibration and point to point (PTP) checkout; testing and balancing; field functional performance testing / performance verification; and owner training.

The commissioning process does not take away from or reduce the responsibility of the system designers or installing contractors to provide a finished and fully functioning facility.

Abbreviations: The following are common abbreviations used in these specifications and in the Commissioning Plan.

- | | | |
|-----|---------|--|
| 1. | A/E | Architect / Engineer. |
| 2. | CA | Commissioning Authority. |
| 3. | CC | Controls Contractor. |
| 4. | CM/GC | Construction Manager / General Contractor. |
| 5. | Cx | Commissioning. |
| 6. | Cx Plan | Commissioning Plan document. |
| 7. | EC | Electrical Contractor. |
| 8. | ES | Equipment Supplier. |
| 9. | FIT | Functional Interface Test. |
| 10. | FPT | Functional Performance Test. |
| 11. | IETA | Independent Electrical Testing Agency. |
| 12. | MC | Mechanical Contractor. |
| 13. | PM | Owner's Project Manager (i.e. client). |
| 14. | OPR | Owner's Project Requirements |
| 15. | EMD | Owner's Engineering Maintenance Director. |
| 16. | PTP | Verification Point to point Verification. |
| 17. | Subs | Subcontractors to CM/GC. |
| 18. | TAB | Test and Balance. |
| 19. | CT | Commissioning Team = CA, PM, EM, CM/GC, A/E, MC, CC, EC, TAB Agency & IETA). |

If a commissioning firm is used to help facilitate commissioning, the Cx firm shall be a totally independent testing organization, with no corporate affiliation with any MC, CM/GC, CC or A/E firm, who specializes in independent testing / verification of HVAC / mechanical and electrical systems. The Cx firm shall carry professional liability insurance and shall employ both mechanical and electrical, graduate engineers, as well as Associated Air Balance Council (AABC) or National Environmental Balancing

SECTION 01 91 00 - COMMISSIONING

Bureau (NEBB) certified field testing engineers. The Cx firm's principal CA shall be a registered professional engineer, with a minimum 10 years HVAC / mechanical design, Cx and field testing experience.

1.2 COORDINATION

Commissioning Team (CT): The make-up of the Cx team shall be as follows: the commissioning authority (CA); the owner's construction representative or construction manager (CM/GC); the owner's project manager (PM); the architect and design engineers (A/E); the mechanical contractor (MC); the electrical contractor (EC); the TAB agency; the independent electrical testing agency (IETA); the controls contractor (CC); the building envelope testing contractor, and any other applicable installing subcontractor or supplier of equipment. Also, if known, the owner's engineering maintenance director (EMD) shall also be considered a member of the Cx team.

Management: The CA shall be the owner, contracted directly by the owner, or contracted by the owner's designated representative. The CA shall direct and coordinate the project Cx activities. All CT members shall work together as a unit to fulfill both their Cx responsibilities (as described herein, and in the Cx Plan) and their individually contracted responsibilities in order to meet the objectives of the Contract Documents, and the stated design intent.

Scheduling: The CA shall work with the PM and CM/GC according to established protocols to schedule the Cx activities. The CA will provide sufficient notice to the CM/GC and PM for scheduling Cx activities. The CM/GC will integrate all Cx activities into the master schedule. All parties will address scheduling problems and make necessary notifications in a timely manner in order to expedite the Cx process. The CA will provide the initial schedule of milestone Cx events (on a percent project completion basis) at the Cx kickoff or scoping meeting, and the preliminary Cx Plan shall provide a format for implementing this schedule. As construction progresses, more detailed schedules will be developed by the CA and updated and submitted to the CM/GC, via revisions of the Preliminary Cx Plan.

1.3 COMMISSIONING PROCESS

Cx Plan: The purpose of the Cx plan shall be to provide guidance in the execution of the Cx process. A preliminary Cx Plan shall be provided at, or before, the initial Cx scoping meeting. The CA will update the Cx plan periodically as the project progresses, issuing a final Cx plan just prior to the start of acceptance phase testing. In the event of conflicts between the Cx Plan and Project Specifications, Project Specifications shall take precedence.

Cx Process: The following is a brief overview of typical Cx tasks.

1. Cx begins at project inception, by documenting the Owner's Project Requirements. All further design and construction activities must support the OPR.
2. During the design phase the CA shall participate in both reviews of design concept and intent, and later, the actual design documents.
3. Cx during the construction phase shall begin with the initial Cx scoping meeting, which shall be conducted by the CA. During this meeting, the CA shall review the Cx process with the CT members, and distribute the preliminary Cx Plan.

SECTION 01 91 00 - COMMISSIONING

4. The CA shall periodically attend, as needed, regularly scheduled (by CM/GC) construction meetings throughout the construction phase in order to keep CT members apprised of: Cx process milestones and scoping / coordination issues; scheduling of Cx activities; and status / resolution of identified deficiencies and miscellaneous issues.
5. The CA shall facilitate controls coordination meetings between the owner, A/E, MC, CC and EC to ensure control systems algorithms will meet the Owner's Project Requirements.
6. The CA shall facilitate selecting building envelope tests applicable to the project.
7. Mechanical & electrical equipment / system submittals & documentation shall be submitted to the CA, during the normal submittal review process, for purposes of a concurrent review. Where applicable, submittals shall include detailed start up and checkout procedures.
8. The CA shall work with the CT and applicable Subs in developing start up plans and start up documentation formats, including providing the Subs with sample prefunctional checklists (PCs), via the Cx Plan, to be completed during the start up process and submitted prior to the beginning of the TAB or IETA fieldwork.
9. In general, Cx checkout and performance verification procedures shall proceed from component level to system level to inter-system level. Various equipment / system PCs shall be completed prior to the start of TAB or IETA fieldwork or functional performance testing.
10. The Subs, under their own initiative, shall execute equipment / system PCs and perform start up on equipment they have installed, but shall provide the CT with a tentative schedule prior to commencing these activities. The CA shall randomly witness equipment / system start up with appropriate personnel and document whether or not checklists and start up procedures have been completed in a satisfactory manner, and in accordance with the project documents.
11. The TAB agency shall be released on a system-by-system basis to begin TAB fieldwork, after signed & certified PCs have been received by the CT, from the installing contractor, for the applicable system.
12. At the completion of the TAB or IETA fieldwork, the Cx authority shall conduct a final TAB report verification on randomly selected systems. The CA shall randomly select a maximum of 25% of the final TAB report data for purposes of verification. If 10% or more of the retested items are found to be plus or minus 10% or more out-of-tolerance of published final TAB (or IETA) report values, then the TAB agency (or IETA) shall be liable for retesting part or all of the specific system before undergoing further performance verification. However, all out-of-tolerance values identified shall be corrected. The TAB agency (or IETA) shall make an allowance in their contract price for the additional time needed to complete any required retesting.
13. The CA shall, with the assistance of the CT, develop specific equipment and system FPT procedures.
14. The FPT procedures shall be executed by the Subs, under the supervision of the CA.
15. Items of non-compliance in material, installation or setup shall be corrected, and the system re-tested, at the Sub's expense.
16. The CA shall review the O&M documentation for completeness.
17. All Cx / FPT procedures shall be completed prior to substantial completion, except for opposed season system checks.
18. The CA shall review, confirm the acceptability of, and help coordinate (together with the CM/GC) the training provided by the Subs and verify that all such training was completed satisfactorily.

SECTION 01 91 00 - COMMISSIONING

19. CA shall issue a complete bound final Cx report to the owner.

1.4 RESPONSIBILITIES

The responsibilities of various parties in the Cx process (i.e. members of the CT) are described in this section. The project responsibilities of the mechanical contractor, TAB agency and controls contractor are itemized under Division 23, those of the electrical contractor and IETA under Division 26, and those of the other sections where requirements of other divisions are found. It is noted that the services listed for the various CT members (other than the CA) are not provided for under this contract, but have been delineated here to help clarify the Cx process.

Architect (of A/E):

1. Does not manage the CA's contract; said contract managed directly by owner or owner's designated representative (i.e. owner's PM or program manager, etc.).
2. Attend the initial Cx scoping meeting and regularly scheduled construction meetings where the CT's attendance has been requested.
3. Perform normal submittal review, construction observation, as built drawing preparation, O&M manual preparation, etc., as contracted.
4. Provide any design narrative documentation requested by the CA.
5. Coordinate resolution of system deficiencies identified during Cx construction and acceptance phases, according to the Contract Documents.
6. Prepare and submit final as built design intent documentation for inclusion in the Cx Manual. Review and approve the O&M manuals.
7. Coordinate resolution of design non-conformance and design deficiencies identified during warranty-period Cx.

Mechanical and Electrical Designers/Engineers (of the A/E):

8. Perform normal submittal review, construction observation, as built drawing preparation, etc., as contracted. One site observation should be completed just prior to system start up.
9. Provide any design narrative and control sequence documentation requested by the CA. The designers shall assist (along with the contractors) in clarifying the operation and control of commissioned equipment in areas where the specifications, control drawings or equipment documentation is not sufficient for writing detailed FPT procedures.
10. Attend the initial Cx scoping meeting and regularly scheduled construction meetings where the CT's attendance has been requested.
11. Participate in the resolution of system deficiencies identified during Cx construction and acceptance phases, according to the Contract Documents.
12. Prepare and submit the final as built design intent and operating parameters documentation for inclusion in the Cx manual. Review and approve the O&M manuals.
13. Provide a presentation at the first training session for the owner's personnel.
14. Participate in the resolution of non-conformance and design deficiencies identified during warranty-period Cx.

SECTION 01 91 00 - COMMISSIONING

Cx Authority (CA):

15. The CA is not responsible for design content, design criteria, compliance with codes, design or general construction scheduling, cost estimating, or construction management. The CA may assist with problem solving and / or resolving non-conformance or deficiency issues, but ultimately that responsibility resides with the general contractor and the A/E. The primary role of the CA shall be as follows: develop and coordinate the execution of the Cx plan; review project design documents and equipment submittals; inspect, observe and document the status of the construction as the installation progresses via periodic site inspections and follow-up written inspection reports; conduct performance verification of the final submitted TAB or IETA report; and conduct field FPT of completed HVAC / mechanical and electrical systems to verify compliance with the documented design intent and the Contract Documents. The installing contractors shall provide all applicable tools and/or personnel to start up, check-out and functionally test equipment and systems, except for specified testing with portable data-loggers (if applicable), which shall be supplied and installed by the CA.
16. The CA shall coordinate and direct the Cx activities in a logical, sequential and efficient manner utilizing its technical expertise as well as the following: consistent test protocols and FPT forms; centralized documentation; clear and regular communications and consultations with all necessary parties (i.e. members of the CT); and periodically updated Cx event schedules.
17. In conjunction with the CM/GC, coordinate Cx activities among all contractors, sub-trades and equipment suppliers to ensure that Cx activities are being scheduled into the master schedule.
18. Plan and conduct initial Cx scoping meeting. Attend periodically, as needed, regularly scheduled (by CM/GC) construction meetings throughout the construction phase in order to keep CT members apprised of: Cx process milestones and scoping / coordination issues; scheduling of Cx activities; and status / resolution of identified deficiencies and miscellaneous issues.
19. Prepare the Cx plan, and ensure its distribution for review and comment.
20. Revise the Cx plan as required during construction phase.
21. Request and review additional information required to perform Cx tasks including O&M materials, contractor start up and checkout procedures.
22. Review and provide written comments on normal contractor submittals applicable to systems being commissioned for compliance with Cx needs concurrent with the A/E reviews.
23. Write and distribute sample PCs and start up checklists.
24. Develop start up and initial systems checkout plan with Subs.
25. Perform site visits, as necessary, to observe component and system installations. Attend selected construction and / or job-site planning meetings to obtain information on construction progress. Assist in resolving any discrepancies.
26. Before start up, gather and review the current control sequences and work with contractors and design engineers until sufficient clarity has been obtained, in writing, to be able to write detailed FPT procedures.
27. Randomly witness HVAC / mechanical systems piping testing and flushing procedures. Document this testing and include the documentation in O&M manuals. Notify owner's project manager of any deficiencies in results or procedures.

SECTION 01 91 00 - COMMISSIONING

28. Randomly witness ductwork air leakage testing (DALT) procedures. Document this testing and include the documentation in O&M manuals. Notify owner's project manager of any deficiencies in results or procedures.
29. Monitor and randomly observe equipment start ups and initial system operations tests and checks to ensure that all results are documented as the checks are done.
30. Confirm/verify pre-functional tests and start up checklists procedures have been accurately completed.
31. Review TAB execution plan and estimated time.
32. Monitor controls point to point checks done by the controls contractor, and ensure that all results are documented as the checks are done.
33. Perform random functional performance checks of the control system prior to TAB fieldwork being executed, to confirm that CC has implemented acceptable PTP checkout procedures.
34. Review final TAB (or IETA) report and conducts final TAB (or IETA) report performance verification.
35. With necessary assistance and review from installing contractors, write the FPT procedures for equipment and systems. This shall include any energy management control system trending, stand-alone data logger monitoring or manual functional testing, if required. Submit to PM for review and for approval, if required.
36. Direct the contractors to operate equipment and systems as required to ensure that all required FPTs are carried out for verification purposes.
37. Facilitate and oversee the conducting of all FPTs and document the results.
38. Analyze any functional performance trend logs and monitoring data to verify performance.
39. Randomly witness performance testing of smoke control systems and all other owner contracted tests or tests by manufacturer's personnel over which the CA may not have direct control. Document these tests and include this documentation in Cx Record in O&M manuals.
40. Maintain a master deficiency (i.e. Action Item Summary) and resolution log and a separate testing record. Provide the PM with written progress reports and test results with recommended actions and help the PM coordinate the resolution of non-compliance issues and design deficiencies identified during all phases of Cx.
41. Ensure that all required O&M manuals, instructions and demonstrations are provided to the Owner's designated operating staff.
42. Review equipment warranties to ensure that the owner's responsibilities are clearly defined. Verify that installing contractors have maintained appropriate maintenance logs, where applicable, of all interim maintenance tasks performed on all started-up equipment, so that manufacturer's warranties are not voided prior to the equipment being turned over to the owner. Verify that installing contractors' maintenance log is submitted when the equipment is officially released to the owner.
43. Prepare and submit a final Cx Report, which documents all checks and tests done throughout the Cx process, and the results obtained from same.
44. Oversee and confirm acceptability of the training of the owner's operating personnel.
45. Coordinate and supervise required seasonal or deferred testing and deficiency corrections.

SECTION 01 91 00 - COMMISSIONING

46. Return to the site at 10-months into the 12-month warranty period and review with facility staff the current building operation and the condition of outstanding issues related to the original and seasonal Cx. Also, interview facility staff and identify problems or concerns they have operating the building as originally intended. Make suggestions for improvements and for recording these changes in the O&M manuals. Identify areas that may come under warranty or under the original construction contract. Assist facility staff in developing reports, documents, and requests for services to remedy outstanding problems.
47. Alternate: Assist in the development of a preventative maintenance plan, a detailed operating plan, an energy and resource management plan, and as built documentation.

Owner's Project Manager (PM):

48. Facilitate the coordination of the Cx work by the CA and with the CM/GC and CA help ensure that Cx activities are being scheduled into the master schedule.
49. Review and approve the final Cx plan.
50. Attend the initial Cx scoping meeting and regularly scheduled construction meetings where the CT's attendance has been requested.
51. Perform the normal review of contractor submittals.
52. Ensure that a copy of all design & construction documents, addenda, change orders and mechanical and electrical equipment / systems submittals and shop drawing related to commissioned equipment has been furnished to the CA for purposes of a concurrent review.
53. Review and approve the FPT procedures submitted by the CA, prior to testing.
54. When necessary, observe and witness installing contractors' execution of PC & equipment start up and FPT of selected equipment.
55. Review Cx progress and submitted deficiency reports.
56. Coordinate the resolution of non-compliance issues and design deficiencies identified in all phases of Cx.
57. Assist the CM/GC in coordinating the training of the owner's personnel.
58. Manage the contract of the A/E, CM/GC and CA.
59. Warranty Period: Assist the CA as necessary in the seasonal or deferred testing and deficiency corrections required by the specifications.

Construction Manager / General Contractor (CM/GC):

60. Participate in the mechanical / electrical systems Cx process by facilitating the coordination of the Cx work with the PM and CA to ensure that Cx activities are being scheduled into the master schedule.
61. Ensure that the various installing contractors perform all assigned Cx responsibilities as specified.
62. Ensure that the TAB agency and independent electrical testing agencies (IETA) perform all assigned Cx responsibilities as specified.
63. Furnish a copy of all design & construction documents, addenda, change orders and mechanical and electrical equipment / systems submittals and shop drawing related to commissioned equipment to the CA for purposes of a concurrent review.
64. Incorporate into each issued purchase order or subcontract, written requirements for submittal data, O&M data, Cx tasks and responsibilities, and owner training requirements.

SECTION 01 91 00 - COMMISSIONING

65. The CM/GC shall facilitate communications among all contractors and suppliers and other CT members, and shall foster the necessary cooperative action. The CM/GC shall attend the initial Cx scoping meeting and as necessary, request the CA's and CT's attendance at applicable regularly scheduled construction meetings to facilitate the Cx process. In addition, the CM/GC shall help ensure that action items arising from meeting discussions are satisfactorily addressed, as required, to enable the Cx process to proceed on schedule.
66. Ensure that all Subs execute their Cx responsibilities according to the Contract Documents and schedule.
67. In the event that any scheduled equipment or system start ups or FPTs are terminated because the CA or the design engineer(s) discover deficient or incomplete work, or due to the non-attendance of required contractor or equipment manufacturer's personnel, the contractor or sub-contractor responsible for the termination shall also be held responsible for paying reasonable costs of time and travel expenses of any or all of the following representatives who were physically present for the purpose of witnessing the start up or the FPT: the CA, the mechanical engineer, the electrical engineer, the owner. The owner may provide a statement to the general contractor identifying the specific activity that was terminated, the scheduled date, and a list of those in attendance, along with their reasonable time and travel expense costs.
68. Coordinate the training of the owner's personnel.
69. Prepare O&M manuals according to the Contract Documents, including clarifying and updating the original sequence of operation to as built conditions.
70. Warranty Period: Ensure that Subs execute seasonal or deferred FPT, witnessed by the CA, according to the specifications. Ensure that Subs correct deficiencies and make necessary adjustments to O&M manuals and as built drawing for applicable issues identified in any seasonal testing.

Mechanical Contractor:

71. The mechanical contractor's Cx team representative shall have the authority to make decisions on behalf of the mechanical contractor as they relate to the organization and scheduling of Cx. The representative shall help ensure that communications are maintained between Division 15 contractors, equipment suppliers and all other Cx team members. One specific responsibility shall be to attend the initial Cx scoping meeting, and all subsequent regularly scheduled construction meetings where the CA's and CT's attendance has been specifically requested. Help ensure that action items arising from mechanical issues are addressed in a timely manner to allow the Cx process to proceed on schedule.
72. Shall ensure that his sub-contractors include in their quotes, the cost of participating in the Cx process as described herein.
73. If applicable (i.e. the controls contractor is a subcontractor under the mechanical contractor), the mechanical contractor shall ensure that the HVAC / mechanical systems controls contractor performs its Cx responsibilities.
74. Provide instruction and demonstrations for the Owner's designated engineering maintenance staff, in conjunction with the Cx authority and the design engineer and with the participation of qualified technicians from major equipment suppliers and the controls contractor.
75. Include specified requirements for submittal data, O&M data and training information in each purchase order or sub-contract written.

SECTION 01 91 00 - COMMISSIONING

76. Ensure cooperation and participation of specialty sub-contractors such as sheet metal, piping, refrigeration, and water treatment as applicable.
77. Ensure participation of major equipment manufacturers in appropriate start up, testing and training activities. In addition, ensure that copies of manufacturers' technician's equipment PCs or start-up / checkout paperwork are submitted to the CT for its information and reference.
78. Notify the CA, in writing, a minimum of two weeks in advance of scheduled equipment and system start ups, so that the CA may witness system verifications, and equipment and system start ups.
79. Provide sufficient personnel to assist the CA as required during system verification and FPT.
80. Prior to mechanical equipment / system start up, inspect, check and confirm the correct and complete installation of all equipment and systems, utilizing either the PCs included in the Cx plan, or an alternate start-up checklist approved by the CT. Document the results of all inspections and checks on the checklists and sign them, certifying that start-up work has been satisfactorily implemented. If deficient or incomplete work is discovered, ensure corrective action is taken and re-check until the results are satisfactory, and the system is ready for safe start up.
81. If applicable (i.e. the TAB agency is a subcontractor under the mechanical contractor), notify the CA a minimum of two weeks in advance, of the time when TAB fieldwork will begin. Attend the initial TAB scoping meeting for review of the TAB procedures.
82. Provide equipment and systems start up resources as specified and required. If during an attempted equipment or system start up, deficient or incomplete work is discovered that would preclude safe operation, the start up shall be aborted until corrective action has been taken. Ensure such action is taken and verified before re-scheduling a new start up. Those responsible for deficient or incomplete work will be responsible for all associated costs.
83. Implement system functional performance checks in advance, utilizing the sample FPT forms provided in the Cx plan, to ensure that all equipment and systems are fully functional and ready for the CA to witness formal FPT.
84. Operate equipment and systems for FPTs in accordance with the Cx plan and as directed by the Cx authority. If improper functionality, incomplete work, or other deficiencies affecting system performance are discovered, the FPTs will be aborted by the CA. Those responsible for deficient or incomplete work will be responsible for all associated costs in accordance with Section 17100. Mechanical contractor shall ensure that all corrections necessary for full and complete system operation, as specified, are completed or otherwise satisfactorily addressed. Upon correction of submitted FPT action items, in conjunction with the CC and other applicable sub-contractors, carry out preliminary functional performance checks to confirm correct operation before requesting the CA to reschedule the FPTs for the system in question.
85. Prepare, for use by the CA, a preliminary schedule for: O&M manual submission (preliminary); pipe and duct system leakage testing; piping systems flushing and cleaning; equipment start up; mechanical system operation; TAB fieldwork; and other miscellaneous task completion. Update schedule as appropriate throughout the construction period.
86. Attend initial O&M staff training session, and conduct mechanical system orientation and inspection at the equipment placement completion stage.

SECTION 01 91 00 - COMMISSIONING

87. Update drawings to as built condition and review with the CA. In addition, gather O&M data on all equipment, and assemble in binders as required by the Cx specification. Submit preliminary O & M manuals to CA as soon as all system / equipment submittals have been approved. O&M manuals shall be properly tabbed by equipment classification or Division 15 specification number, and shall be as “user-friendly” as possible and shall include the following: copies of specific submitted performance data on the particular equipment; performance curves for all fans, pumps, airflow / waterflow monitoring stations, pump triple-duty valves, circuit setter / auto-flow valves, etc.; operating and maintenance instructions including suggested equipment PC and required maintenance intervals; all applicable equipment maintenance logs; and appropriate applicable drawings.
88. Participate in, and schedule, vendors and contractors to participate in the O&M staff training sessions as set up by the CM/GC.
89. Provide written notification to the CM/GC and CA that the following work has been completed in accordance with the contract documents and the equipment, systems and sub-systems are operating as required.
 - a. HVAC / mechanical equipment including all fans, air handling units, dehumidification units, ductwork, dampers, terminals and all Division 23 equipment.
 - b. Refrigeration equipment, pumping systems and heat rejection equipment.
 - c. Fire stopping in all fire rated construction, including fire and smoke damper installation, caulking, gasketing and sealing of smoke barriers.
 - d. Dedicated smoke control systems including stairway pressurization and atrium systems.
 - e. Non-dedicated systems using the air-handling units for smoke control.
 - f. Fire detection and smoke detection devices furnished under other divisions of the specifications as they affect the operation of the smoke control systems.
 - g. That the building control system is functioning to control mechanical equipment and smoke control systems as specified.
 - h. Provide a complete set of as built drawings and O&M manuals to the CA as well as completing, signing, and submitting all mechanical systems / equipment PCs.

Controls Contractor:

90. Include the cost in his contract of participating in the Cx process as described herein.
91. Review system design for controllability with respect to equipment selected for the project.
92. Review and confirm in writing that a proper hardware specification exists to permit FPT as required by the project specifications and control sequences of operation.
93. Review and confirm in writing that proper safeties and interlocks are included in the project design documents.
94. Ensure that control valves and actuators have been properly sized, based upon design pressure drops, and that selected control valves will result in the airflow / waterflow capacity control specified. Include all valve sizing information in control valve submittal.

SECTION 01 91 00 - COMMISSIONING

95. Ensure that control dampers have been properly sized to control airflows as specified. Review and confirm in writing proper damper positioning for mixing to prevent stratification. Ensure correct actuator vs. damper movement for smooth operation, and include damper sizing, control method and actuator selection data in control damper submittal.
 96. Ensure that temperature, pressure, humidity, CO₂, airflow and waterflow sensor ranges have been properly selected, and include supporting data with submittal.
 97. Clarify all questions concerning control sequences of operation with the design engineer.
 98. Attend initial Cx scoping meeting scheduled by the CA, and all subsequent regularly scheduled construction meetings where the CA's and CT's attendance has been specifically requested. Help ensure that action items arising from control system issues are addressed in a timely manner to allow the Cx process to proceed on schedule.
 99. Provide the following submittals to the CA for review:
 - a. All operation and maintenance manuals including all hardware and software (i.e. application software and project applications code manuals) submittals.
 - b. Control panel construction shop drawings.
 - c. Diagrams showing all control points, sensor locations, point names, actuators, controllers and where necessary, points of access, all superimposed on diagrams of the physical equipment.
 - d. Narrative description of all control sequences for each piece of equipment controlled.
 - e. Logic diagrams showing the logic flow of all control sequences.
 - f. A list of all control points, including analog inputs, analog outputs, digital inputs and digital outputs. Include the values of all parameters for each system point. Provide a separate list for each stand-alone control unit.
 - g. Provide a program write-up, organized in the same manner as the control software. This narrative shall describe the logic flow of the software and the functions of each routine and sub-routine. It should also explain individual math or logic operations that are not clear from reading the software listing.
 100. Inspect, check and confirm the proper installation and performance of controls/BAS hardware and software provided by others.
 101. Integrate installation and programming scheduling with construction and Cx schedules.
 102. Inspect, check and confirm the correct installation and operation of input and output field points and devices through documented and signed off point to point checkout sheets.
 103. Provide thorough training to owner's engineering operations personnel on hardware operations and programming, and the application program for the system, in accordance with the O&M staff training program in the Cx plan.
 104. In conjunction with the mechanical contractor, demonstrate system performance to the CA including all modes of system operation (e.g. occupied, unoccupied, emergency, etc.) during FPT. If improper functionality, incomplete work, or other deficiencies affecting system performance are discovered, the FPTs will be aborted by the CA. Those responsible for deficient or incomplete work will be responsible for all associated costs.
-

SECTION 01 91 00 - COMMISSIONING

105. Provide control system technicians to assist during system verification and FPT. The BAS controls contractor shall make two (2) technician available to the CA throughout the FPT phase of the commissioning process. One of the technicians shall be familiar with the controls software and programming and the other shall be capable of making controls system hardware repairs during FPT. The BAS controls contractor shall also submit a copy of his controls point-to-point (PTP) checkout sheets to the CA, prior to the start of the mechanical system FPT.
106. Provide support and coordination with TAB agency on all interfaces between controls and TAB scopes of work. Provide, at no additional cost to the TAB and Cx agencies, all devices, such as portable operator's terminals and all software for the TAB agency to use in completing TAB procedures.
107. Provide trend data as requested for the systems being commissioned.

TAB Agency:

108. Include the cost in his contract of participating in the Cx process as described herein.
109. Attend initial Cx scoping meeting scheduled by the CA, and all subsequent regularly scheduled construction meetings where the CA's and CT's attendance has been specifically requested, both prior to and during TAB fieldwork.
110. Submit proposed TAB procedures to the CA and design engineer for review and acceptance within 90 days of contract award.
111. Attend the TAB planning meeting scheduled by the CM/GC. Be prepared to discuss the procedures that shall be followed in testing, adjusting and balancing the HVAC / mechanical systems.
112. Submit deficiency reports generated during TAB fieldwork to appropriate installing contractors, and to the CT, so that immediate attention can be given to addressing and resolving the various deficiencies identified.
113. At the completion of the TAB work and prior to substantial completion, submit the final TAB report to the general contractor (or construction manager) with copies to the Owner, CA and the design engineer.
114. Participate in performance verification of the final TAB report by the CA. The TAB agency shall provide one (1) technician with full instrumentation for the purpose of verifying the data submitted in the final TAB report. This will consist of repeating a sample (25%) of the measurements contained in the TAB report as directed by the CA.

Electrical Contractor:

115. Include the cost in his contract of participating in the Cx process as described herein.
116. Review design with respect to providing power to the mechanical equipment and verify the following:
 - a. That proper hardware specifications exist to accomplish the specified functional performance and sequences of operation required by the project documents.
 - b. That proper safeties and interlocks are included in the design of electrical connections for mechanical equipment.
117. Attend initial Cx scoping meeting scheduled by the CA, and all subsequent regularly scheduled construction meetings where the CA's and CT's attendance has been specifically requested. Help ensure that action items arising from electrical system issues are addressed in a timely manner to allow the Cx process to proceed on schedule.

SECTION 01 91 00 - COMMISSIONING

118. Schedule work so that required electrical installations are completed, and so that systems verification checks and FPTs can be carried out on schedule.
119. Inspect, check and confirm in writing the proper installation and performance of all electrical systems / services provided.
120. Provide electrical system technicians to assist during system verification and FPT as required by the CA.

Independent Electrical Testing Agency:

121. Include the cost in his contract of participating in the Cx process as described herein.
122. Attend initial Cx scoping meeting scheduled by the CA, and all subsequent regularly scheduled construction meetings where the CA's and CT's attendance has been specifically requested, both prior to and during IETA fieldwork.
123. Submit proposed electrical system testing procedures to the CA and design engineer for review and acceptance within 90 days of contract award.
124. Attend the IETA planning meeting scheduled by the CM/GC. Be prepared to discuss the procedures that shall be followed in testing the electrical systems.
125. Submit deficiency reports generated during IETA fieldwork to appropriate installing contractors, and to the CT, so that immediate attention can be given to addressing and resolving the various deficiencies identified.
126. At the completion of the IETA work and prior to substantial completion, submit the final IETA report to the general contractor (or construction manager) with copies to the Owner, CA and the design engineer.
127. Participate in performance verification of the final IETA report by the CA. The IETA agency shall provide one (1) technician with full instrumentation for the purpose of verifying the data submitted in the final IETA report. This will consist of repeating a sample (25%) of the measurements contained in the IETA report as directed by the CA.

Equipment Suppliers:

128. Provide all requested submittal data including detailed start up procedures and specific responsibilities of the owner to keep warranties in force.
129. Assist in equipment start-up / checkout and testing per agreement with Subs.
130. Include all special tools and instruments (only available from vendor, specific to a piece of equipment) required for testing equipment according to these Contract Documents in the base bid price to the contractor, except for stand-alone data-logging equipment that may be used by the CA.
131. Provide information requested by CA regarding equipment sequence of operation and testing procedures.
132. Review test procedures for equipment installed by factory representatives.

1.5 DEFINITIONS

Design Narrative or Design Documentation: Sections of either the Design Intent or Basis of Design.

Factory Testing: Testing of equipment on site or at the factory by factory personnel with an owner's representative present.

SECTION 01 91 00 - COMMISSIONING

Functional Performance Test (FPT): Test of the dynamic function and operation of equipment and systems using manual (direct observation) or monitoring methods. FPT is the dynamic testing of systems (rather than just components) under full operation (e.g., the chiller pump is tested interactively with the chiller functions to see if the pump ramps up or down to maintain the differential pressure set point). Systems are tested under various modes, such as during low cooling or heating loads, high loads, component failures, unoccupied, varying outside air temperatures, fire alarm, power failure, etc. The systems are run through numerous control systems' sequences of operation, and components are verified to be responding per the specified design sequences. Traditional air or water test and balancing (TAB) is not FPT, in the Cx sense of the word. The TAB agency's primary work is setting up the systems flows and pressures as specified, while FPT is verifying that which has already been set up. However, prior to the commencement of FPT, the CA shall conduct a final TAB report verification. The Cx authority develops the FPT procedures in a sequential written form, coordinates, oversees and documents the actual testing, which is usually performed by the installing contractor or vendor. FPTs are performed after PCs have been submitted, equipment start up / checkout have been completed, and all TAB or IETA fieldwork has been completed, and a report issued.

Construction Manager: The prime contractor for this project. Generally refers to all the CM/GC's subcontractors as well. Also referred to as the Contractor, in some contexts.

Indirect Indicators: Indicators of a response or condition, such as a reading from a control system screen reporting a damper to be 100% closed.

Manual Test: Using hand-held instruments, immediate control system readouts or direct observation to verify performance (contrast to analyzing monitored data taken over time to make the "observation").

Monitoring: The recording of parameters (flow, current, status, temperature, pressure, etc.) of equipment operation using data-loggers or the trending capabilities of control systems.

Simulated Signal: Writing over a sensor value in the control system to see the response of a system (e.g., changing the outside air temperature value from 50°F to 75°F to verify economizer operation).

Owner – Contracted Tests: Tests paid for by the owner outside the CM/GC's contract and for which the CA does not oversee. These tests will not be repeated during FPTs, if properly documented.

Phased Cx: Cx that is completed in phases (by floors, for example) due to the size of the structure or other scheduling issues, in order to minimize the total construction time.

SECTION 01 91 00 - COMMISSIONING

Pre-functional Checklist (PC): A list of items to inspect and elementary component tests to conduct to verify proper installation / start-up / checkout of equipment. Sample PCs are provided by the CA in the preliminary Cx Plan; however, the Subs may utilize their own PCs or PCs provided by their equipment suppliers, provided that accepted industry start-up procedures are followed. Correct start-up procedures & checklists are essential for ensuring that equipment and systems are checked out properly before being brought on-line and made operational. PCs are primarily static inspections and procedures to prepare the equipment or system for initial operation (e.g., belt tension, oil levels OK, labels affixed, gages in place, sensors calibrated, etc.). However, some PC items entail simple testing of the function of a component, a piece of equipment or system (such as measuring the voltage imbalance on a three-phase pump motor of a chiller system, or the rotation on a pump or fan). The word pre – functional refers to before functional testing. PC augment and are combined with the manufacturer’s start up checklist. Even without a Cx process, contractors will typically perform some of the pre-functional checklist items a CA will recommend; however, few contractors document in writing the execution of these checklist items. Start-up checklists shall be utilized on this project to help ensure that the independent testing phases (i.e. TAB / IETA and FPT) of the project proceed smoothly without unnecessary delays. Each piece of equipment must undergo proper start-up procedures, no exceptions.

Project Manager (PM): The contracting and managing authority for the owner over the design and/or the construction of the project.

Sampling: Functionally testing a fraction (i.e. representative sample) of the total number of identical or near identical pieces of equipment.

Seasonal Performance Tests: FPT that is deferred until the system(s) will experience conditions closer to their design conditions.

Simulated Condition: Condition that is created for the purpose of testing the response of a system (e.g., applying a hair blower to a space sensor to see the response in a VAV box).

Specifications: The construction specifications of the Contract Documents.

Start-up: The initial starting or activating of dynamic equipment, including executing PCs.

Subs: The subcontractors to the CM/GC who provide and install building components and systems.

Test Procedures: The step-by-step process, which must be executed to fulfill the test requirements. The test procedures are developed by the CA.

Test Requirements: Requirements specifying what modes and functions, etc. shall be tested. The test requirements are not detailed test procedures. The test requirements are specified in the Contract Documents.

Trending: Monitoring using the building automation system (BAS).

SECTION 01 91 00 - COMMISSIONING

Vendor: Supplier of equipment.

Warranty Period: Warranty period for the entire project, including equipment components. Warranty begins at Substantial Completion and extends for at least one year, unless specifically noted otherwise in the Contract Document and accepted submittals.

1.6 SYSTEMS REQUIRING INTENSE COMMISSIONING FOCUS

The following examples are systems usually requiring intense commissioning focus. This list shall be expanded or condensed as warranted by the Owner’s Project Requirements:

	HVAC / Mechanical Systems		Electrical Systems
	Pumps		Main Power
	Mechanical Piping Systems		Fire and smoke alarm
	Ductwork & Duct Specialties		Fire protection systems
	Variable Frequency Drives		Communication system
	Terminal Units (Air)		Emergency Power
	Air Handling Units and DOAS Units		Lighting Control system
	Pumps and Heat Exchangers		
	Exhaust Fans		Other
	HVAC Control Systems		Domestic HW system / equipment
	Tab Fieldwork		Rainwater harvesting system
	Fire And Smoke Dampers		Building Envelope Systems
	Laboratory Systems		

02 PRODUCTS

1.7 TEST EQUIPMENT

All standard test equipment required to perform equipment / system start up, initial checkout (including PTP checkout) and required FPT shall be provided by the applicable (i.e. Division 23 or 26) contractor for the equipment / system being tested. For example, the Division 23 MC shall be responsible for all standard test equipment required for the checkout of HVAC / mechanical systems, except for equipment specific to and used by TAB in their Cx responsibilities, and the Division 23 CC shall be responsible for test equipment for checkout of the BAS system controls. Two-way radios shall be provided by the Division contractor.

Special equipment, tools and instruments (only available from vendor, specific to a piece of equipment) required for test equipment, according to these Contract Documents, shall be included in the base bid price to the CM/GC and left on site, except for stand-alone data logging equipment that may be used by the CA.

SECTION 01 91 00 - COMMISSIONING

All test equipment shall be of sufficient quality and accuracy to test and /or measure system performance with the tolerances required by the Specifications. If not otherwise noted, the following minimum requirements apply; Temperature sensors and digital thermometers shall have a certified calibration within the past year and a resolution of $\pm 0.1^{\circ}\text{F}$. Pressure sensors shall have an accuracy of $\pm 2.0\%$ of the value range being measured (not full range of meter) and have been calibrated within the last year. All equipment shall be calibrated according to the manufacturer's recommended intervals and when dropped or damaged. Calibration tags shall be affixed or certificates readily available.

03 EXECUTION**1.8 MEETINGS**

Scoping Meeting: Within 60 to 90 days, depending on building size, prior to the commencement of construction, the CA will schedule, plan and conduct a Cx scoping meeting with the entire CT in attendance. The CA will also provide copies of the preliminary Cx Plan to all CT members, at or before this meeting. Meeting minutes will be compiled and distributed to all parties by the CA.

Miscellaneous Meetings: The CM/GC shall periodically request the CA's and CT's attendance at applicable regularly scheduled construction meetings to facilitate the Cx process. These meetings will cover Cx process coordination, deficiency resolution and planning issues with members of the CT and various Subs. In addition, the CM/GC shall help ensure that action items arising from meeting discussions are satisfactorily addressed, as required, to enable the Cx process to proceed on schedule.

1.9 REPORTING

The CA will provide regular reports to the PM and CM/GC as deemed necessary, with increasing frequency as construction and Cx progresses.

The CA will regularly communicate with all members of the Cx team, keeping them apprised of Cx progress and scheduling changes through memos, field inspection reports, miscellaneous progress reports, etc.

The CA shall maintain a master deficiency (i.e. Action Item Summary) and resolution log and a separate testing record. In addition, the CA will help the PM & CM/GC coordinate the resolution of non-compliance issues and design deficiencies identified in the Action Item Summary and during all phases of Cx.

SECTION 01 91 00 - COMMISSIONING

A final summary report will be provided by the CA, which summarizes the results of the Cx process. The final Cx report shall include: an executive summary of the Cx process; a project narrative covering highlights of all project Cx phases; a detailed summary of all observations, comments and deficiencies noted throughout the Cx process; a summary of FPT results; appropriate conclusions and recommendations; and a value statement detailing the economic impact of Cx to the project. The conclusion and recommendations will focus on evaluating the Cx process issues and identifying areas where the process could be improved. All acquired documentation, logs, minutes, reports, deficiency lists, communications, findings, unresolved issues, etc., will be compiled in appendices and provided with the summary report. PCs, TAB verification results, FPT results and monitoring reports will also be part of the final Cx report.

1.10 SUBMITTALS

The CA will provide appropriate contractors with a specific request for the type of submittal documentation the CA requires to facilitate the Cx work. These requests will be integrated into the normal submittal process and protocol of the construction team. As a minimum, the request will include the manufacturer and model number, the manufacturer's printed installation and detailed start up procedures, full sequences of operation, and O&M data, performance data and performance curves, any performance test procedures, control drawings and details of owner contracted tests.

The CA will review and submit written comments on submittals related to the commissioned equipment for conformance to the Contract Documents. This review is intended to aid in the development of FPT procedures as well as to verify compliance with equipment specifications. The CA will notify the PM, CM/GC and/or A/E where applicable, of omitted items or of items that are not in conformance with the Contract Documents and which require resubmission.

The CA may request additional design narrative from the A/E and Controls Contractor, depending on the completeness of the design intent documentation and control sequences of operation provided with the specifications.

The CA shall review O&M manual documentation for acceptability and completeness to ensure that O&M manuals are as follows: properly tabbed by equipment classification or Division 23 / 26 specification number; as "user-friendly" as possible; include copies of specific submitted performance data for specific equipment; include performance curves for all fans, pumps, airflow / waterflow monitoring stations, pump triple-duty valves, circuit setter / auto-flow valves, etc.; include operating and maintenance instructions including suggested equipment PCs and required maintenance intervals; include all applicable equipment maintenance logs; include appropriate applicable drawings.

1.11 START-UP, PRE-FUNCTIONAL CHECKLISTS (PCs) AND INITIAL CHECKOUT

The following procedures apply to all equipment to be commissioned (See Section 1.6, Systems to be commissioned). Some systems that are not comprised of actual dynamic machinery, e.g., electrical system power quality, may have very simplified PCs and start up procedures.

SECTION 01 91 00 - COMMISSIONING

General: PCs are necessary for ensuring that equipment and systems are made properly operational for TAB or IETA fieldwork, and Cx FPT. PCs help ensure that FPT (and in-depth system checkout) may proceed without unnecessary delays. Each piece of equipment shall receive a full pre-functional checkout, and no sampling strategies shall be used. The pre-functional testing for a given system must be successfully completed prior to the beginning of the TAB or IETA fieldwork, and prior to the start of formal FPT of equipment or systems. The PC's will be integrated into the Cx Alloy software and are to be completed digitally by the responsible contractor.

Start up and Initial Checkout Plan: The CA shall assist the CT members responsible for start up of any equipment in developing detailed start up plans for all equipment. The primary role of the CA in this process is to ensure that written documentation is produced that verifies that equipment / system manufacturer-recommended start-up / checkout procedures have been completed. Parties responsible for PCs and start up are identified in the Cx scoping meeting and on the PC forms.

1. The CA will adapt manufacturer's recommended start-up / checkout procedures in preparing PC forms. These checklists indicate required procedures to be executed as part of start up and initial checkout of the systems and the responsible party.
2. Sample PCs shall be provided by the CA to the CT members, via the preliminary Cx Plan. Installing contractor CT members shall determine which trade is responsible for executing and documenting the various line item tasks and notes indicated on the PCs. Most PC forms will have more than one trade responsible for its execution.
3. The installing contractor CT members responsible for the purchase of various pieces of equipment shall develop the full start-up plan (with the assistance provided by the CA as needed) for that equipment. This shall be accomplished by combining the CA's PCs with both the manufacturer's detailed start up and checkout procedures along with the contractors own standard field checkout sheets. The start-up plan shall include checklists and procedures with specific boxes or lines for recording and documenting the checking and inspections of each procedure and a summary statement with a signature block at the end of the plan.
4. The full start-up plan could consist of something as simple as:
 - a. The CA's PCs.
 - b. The manufacturer's standard written start up procedures copied from the installation manuals with check boxes by each procedure and a signature block added by at the end of the form.
 - c. The manufacturer's normally used field checkout sheets.
5. The installing contractor CT members shall submit full start-up plans for all required equipment / systems to the CA for review and confirmation of acceptability. The CA shall review the start-up plan and PC format for acceptability, noting any procedures that need to be added.
6. The full start-up procedures and all PC forms shall be provided to the A/E and PM for review and approval, depending on management protocol.

SECTION 01 91 00 - COMMISSIONING

Sensor Calibration: Control system PTP checkout and calibration of all sensors shall be included as part of the PCs performed by the Controls Contractor, according to the following procedures:

7. All Sensors: Verify that sensors with shielded cable are grounded only at one end. For sensor pairs that are used to determine a temperature or pressure difference, make sure they are reading within 0.2°F of each other for temperature and within a tolerance of equal to 2% of the reading of each other, for pressure. Tolerances for critical applications will be stricter.
8. Sensors without Transmitters: Standard Application: Make a reading with a calibrated test instrument within 6 inches of the site sensor. Verify that the sensor reading (via the permanent thermostat, gage or building automation system (BAS) is within the tolerances in the table below of the instrument measured value. If not, calibrate or replace sensor.
9. Sensors with Transmitters: Standard Application: Disconnect sensor. Connect a signal generator in place of the sensor. Connect ammeter in series between transmitter and BAS control panel. Using manufacturer's resistance-temperature data simulate minimum desired temperature. Adjust transmitter potentiometer zero until 4mA is read by the ammeter. Repeat for the maximum temperature matching 20mA to the potentiometer span or maximum and verify at the BAS. Reconnect sensor. Make a reading with the calibrated test instrument within 6 inches of the site sensor. Verify that the sensor reading (via the permanent thermostat, gage or building automation system (BAS)) is within the tolerances in the table below of the instrument-measured value. If not, replace sensor and repeat. For pressure sensors, perform a similar process with a suitable signal generator.

Execution of Pre-functional Checklists and Start up:

10. Six (6) weeks prior to start up, the Subs and vendors schedule start up with the PM, CM/GC and CA. The performance of the PC, start up and checkout are directed and executed by the Subcontractor or vendor. When checking off PC, signatures will be required of other Subs for verification of completion of their work.
11. The CA shall observe, at minimum, the procedures for each piece of primary equipment, unless there are multiple units, (in which case a sampling strategy may be used as approved by the CA).
12. For lower-level components of equipment, (e.g., VAV boxes, sensors, controllers), the CA shall observe a sampling of the pre-functional and start up procedures. The sampling procedures are identified in the Cx Plan.
13. The Subs and vendors shall execute start up and provide the CA with a signed and dated copy of the completed start up and pre-functional tests and checklists and/or PTP checkout sheets.
14. Only individuals that have direct knowledge and witness that a line item task on the pre-functional checklist was actually performed shall initial or check that item off. It is not acceptable for witnessing supervisors to fill out these forms.

Deficiencies, Non-Conformance and Approval in Checklists and Start up:

15. The Subs shall clearly list any outstanding items of the initial start up and pre-functional procedures that were not completed successfully on an attached sheet. The procedures form and any outstanding deficiencies are to be provided to the CA within two (2) days of test completion.

SECTION 01 91 00 - COMMISSIONING

16. The CA will review the report and submit it with his comments to the Subcontractor and the PM. The CA shall oversee the Subs and the vendors in collecting and retesting deficiencies or uncompleted items. The installing Subs or vendors shall correct all areas that are deficient in the checklists and tests in a timely manner, and shall notify the CA as soon as outstanding items have been corrected and resubmit an updated start up report and a Statement of Correction on the original non-compliance report. When satisfactorily completed the CA recommends approval of the execution of the checklists and start up of each system to the PM using a standard form.
17. Items left incomplete, which later cause deficiencies or delays during functional testing, may result in back charges to the responsible party. Refer to Part 3.7 herein for details.

1.12 FUNCTIONAL PERFORMANCE TESTING

This sub-section applies to all Cx functional testing for all divisions.

Objectives and Scope: The objective of FPT is to demonstrate that each system is operating according to the documented design intent and Contract Documents. Functional testing facilitates bringing the systems from a state of substantial completion to full dynamic operation. Additionally, during the testing process, areas of deficient performance are identified and corrected, improving the operation and functioning of the systems.

Development of Test Procedures: Before test procedures are written, the CA shall obtain all requested documentation, equipment or systems, including an updated points list, program code, control sequences and parameters. The CA will develop specific test procedures and forms to verify and document proper operation of each piece of equipment and system. Prior to execution, the CA shall provide a copy of the test procedures to the Subcontractor(s) who shall review the tests of feasibility, safety, equipment and warranty protection. The CA shall submit the tests to the A/E for review, if requested.

The CA shall review owner-contracted, factory testing or required owner acceptance tests, including documentation format, and shall determine what further testing or format changes may be required to comply with the Specifications. Redundancy of testing shall be minimized.

The purpose of any given specific test is to verify and document compliance with the stated criteria of acceptance given on the test form. In general, the FPTs will be comprised of the following:

1. Sensor Calibration Checks / Equipment Room.
2. Sensor Calibration Checks / Space.
3. Device Calibration Checks.
4. Sequence of Operation Functional Tests.

SECTION 01 91 00 - COMMISSIONING

Test Methods:

5. FPT and verification will be achieved by a combination of manual testing (persons manipulate the equipment and observe performance) and simultaneous monitoring of the performance via the Building Automation System (BAS). Analysis of the results may also include using the control system's trend log capabilities or stand-alone data loggers. The CA may substitute specified methods referenced in other specification sections, or require an additional method to be executed, other than what was specified, with the approval of the A/E and PM. This may require a change order and adjustment in charge to the Owner. The CA will determine which method is most appropriate for tests that do not have a method specified.
6. Simulated Conditions: Simulating conditions (not by an overwritten value) shall be allowed, though timing the testing to experience actual conditions is encouraged wherever practical.
7. Overwritten Values: Overwriting sensor values to simulate a condition, such as overwriting the outside air temperature reading in a control system to be something other than it really is, shall be allowed, but shall be used with caution and avoided when possible. Such testing methods often can only test a part of a system, as the interactions and responses of other systems will be erroneous or not applicable. Simulating a condition is preferable, e.g., for the above case, by heating the outside air sensor with a heat source rather than overwriting the value or by altering the appropriate set point to see the desired response.
8. Simulated Signals: Using a signal generator which creates a simulated signal to test and calibrate transducers and DDC constants is generally recommended over using the sensor to act as the signal generator via simulated conditions or overwritten values.
9. Altering Set Points: Rather than overwriting sensor values, and when simulating conditions is difficult, altering setpoints to test a sequence is acceptable. For example, to see the AC compressor lockout work at an outside air temperature below 55°F, when the outside air temperature is above 55°F, temporarily change the lockout setpoint to be 2°F above the current outside air temperature.
10. Indirect Indicators: Relying on indirect indicators for responses or performance shall be allowed only after visually and directly verifying and documenting, over the range of the tested of the tested parameters, that the indirect readings through the control system represent actual conditions and responses. Much of this verification is completed during pre-functional testing.
11. Setup: Each function and test shall be performed under conditions that simulate conditions as close as is practically possible. The Subcontractor executing the test shall provide all necessary materials, system modifications, etc. to produce necessary flows, pressures, temperatures, etc. necessary to execute the test according to the specified conditions. At completion of the test, the Subcontractor shall return all affected building equipment and systems, due to these temporary modifications, to their pre-test condition.
12. Trending: During the course of functional testing, the controls contractor is to setup any required trends that are asked by the CT and provide them the data in an organized manner on an excel spreadsheet.

SECTION 01 91 00 - COMMISSIONING

13. Sampling: Multiple identical pieces of non-life-safety or otherwise non-critical equipment may be functionally tested using a sampling strategy. Significant application differences and significant sequence of operation differences in otherwise identical equipment invalidates their common identity. A small size or capacity difference, alone, does not constitute a difference.
14. If at any point, frequent failures are occurring and testing is becoming more troubleshooting than verification, the CA will stop the testing and require the responsible Subcontractor to perform and document a checkout of the remaining units, prior to continuing with functionally testing the remaining units.

Coordination and Scheduling: The Subs shall provide sufficient notice to the CA regarding their completion schedule for the PC and start up of all equipment and systems. The CA will schedule functional tests through the PM, CM/GC, and affected Subs. The CA shall direct, witness and document the functional testing of all equipment and systems. The Subs shall execute the tests.

In general, FPT will be conducted after pre-functional testing and start up has been satisfactorily completed, and after verification of the final TAB report. The control system shall be sufficiently tested and all PTP checkout sheets submitted to the CA for review prior to the start of the TAB field work. Once air balancing and water balancing has been completed and the final TAB report verification concluded, FPT of air-related or water-related equipment or systems can begin. Testing proceeds from components to subsystems to systems. When the proper performance of all interacting individual systems has been achieved, the interface or coordinated responses between systems is checked.

Test Equipment: Refer to CX Authority, Part 2 for test equipment requirements.

Problem Solving: The CA will recommend solutions to problems found; however, the burden of responsibility to solve, correct and retest problems is with the CM/GC, Subs, and A/E.

1.13 DOCUMENTATION, NON-CONFORMANCE AND APPROVAL OF TESTS

Documentation: The CA shall witness and document the results of all FPTs using the specific procedural forms developed for that purpose. Prior to testing, these forms are provided to the PM for review and approval and to the Subs for review. The CA will include the filled out forms in the O&M manuals.

Non-Conformance:

1. The CA will record the results of the FPT on the test forms. All deficiencies or non-conformance issues shall be noted and reported to the Owner and the PM via written interim reports.
2. Corrections of minor deficiencies identified may be made during the tests at the discretion of the CA. In such cases, the deficiency and resolution will be documented on the procedure form.
3. Every effort will be made to expedite the testing process and minimize unnecessary delays, while not compromising the integrity of the procedures.

SECTION 01 91 00 - COMMISSIONING

4. As tests progress and a deficiency is identified, the CA discusses the issue with the executing contractor.
 - a. When there is no dispute on the deficiency and the Subcontractor accepts responsibility to correct it:
 - 1) The CA documents the deficiency and the Sub's response and intentions, and they go on to another test or sequence. After a days work, the CA submits the non-compliance reports to the PM/owner for signature. A copy is provided to the Subcontractor and CA. The Subcontractor corrects the deficiency, signs the statement of correction at the bottom of the non-compliance form certifying that the equipment is ready to be tested and sends it back to the CA.
 - 2) The CA reschedules the test, and the test is repeated.
 - b. If there is a dispute about a deficiency, regarding whether it is a deficiency or who is responsible:
 - 1) The deficiency shall be documented with the Sub's response and a copy given to the PM/Owner and the Sub's representative assumed to be responsible.
 - 2) Resolutions shall be made at the lowest management level possible. Other parties are brought into the discussions as needed. Final interpretive authority is with the A/E. Final acceptance authority is with the Owner Representative.
 - 3) The CA documents the resolution process.
 - 4) Once the interpretation and resolution have been decided, the appropriate party corrects the deficiency, signs a statement of correction and provides it to the CA. The CA reschedules the test, and the test is repeated until satisfactory performance is achieved.
 5. Cost of Retesting:
 - a. The cost for the Subcontractor to retest a pre-functional or functional test, if they are responsible for the deficiency, shall be theirs. If they are not responsible, any cost recovery for retesting costs shall be negotiated with the CM/GC.
 - b. For a deficiency identified, not related to any pre-functional checklist or start up fault, the following shall apply. The CA and PM will direct the retesting of the equipment once at no "charge" to the CM/GC for their time. However, the CA's and PM's time for a second retest will be charged to the CM/GC, who may choose to recover costs from the responsible Sub.
 - c. The time for the CA and PM to direct any retesting required because a specific pre-functional checklist or start up test item, reported to have been successfully completed, but determined during functional testing to be faulty, will be back charged to the CM/GC. The CM/GC may choose to recover costs from the party responsible for executing the faulty pre-functional test.
 6. The contractor shall respond in writing to the CA and PM at least as often as Cx meetings are being scheduled concerning the status of each apparent outstanding discrepancy identified during Cx. Discussion shall cover explanations of any disagreements and proposals for their resolution.
 7. The CA retains the original non-conformance forms until the end of the project.
-

SECTION 01 91 00 - COMMISSIONING

Failure Due to Manufacturer's Defects: If 10% of identical pieces of equipment (size alone does not constitute a difference) fail to perform in accordance with the Contract Documents (mechanically or substantively) due to a manufacturing defect, not allowing it to meet its submitted performance spec, all identical units may be considered unacceptable by the CM/GC or PM. In such case, the Contractor shall provide the Owner with the following:

8. Within one (1) week of notification from the PM, the Contractor or manufacturer's representative shall examine all other identical units making a record of the findings. The findings shall be provided to the PM within two (2) weeks of the original notice.
9. Within two (2) weeks of the original notification, the Contractor or manufacturer shall provide a signed and dated, written explanation of the problem, cause of failures, etc. and all proposed solutions which shall include full equipment submittals. The proposed solutions shall not significantly exceed the specification requirements of the original installation.
10. The PM/Owner will determine whether a replacement of all identical units or a repair is acceptable.
11. Two (2) examples of the proposed solution will be installed by the Contractor and the PM will be allowed to test the installations for up to one week, upon which the PM will decide whether to accept the solution.
12. Upon acceptance, the Contractor and/or manufacturer shall replace or repair all identical items, at their expense and extend the warranty accordingly, if the original equipment warranty had begun. The replacement/repair work shall proceed with reasonable speed beginning within one week from when parts can be obtained.

Approval: The CA notes each satisfactorily demonstrated function on the test form. Formal approval of the functional test is made later after review by the CA and by the PM, if necessary. The CA recommends acceptance of each test to the Owner using a standard form.

1.14 OPERATION AND MAINTENANCE MANUALS

Standard O&M Manuals:

1. The specific content and format requirements for the standard O&M manuals are detailed elsewhere throughout the specifications. Special requirements for the controls contractor and TAB agency are found in their respective sections of the specifications.
2. A/E Contribution: The A/E will include in the beginning of the O&M manuals a separate section describing the systems including:
 - a. The design intent narrative prepared by the A/E and provided as part of the bid documents, updated to as built status by the A/E.
 - b. Simplified professionally drawn single line system diagrams on 8 1/2" x 11" or 11" x 17" sheets. These shall include chillers, water system, condenser water system, heating systems, supply air systems, exhaust systems and others as designated. These shall show major pieces of equipment such as pumps, chillers, boilers, control valves, expansion tanks, coils, service valves, etc.

SECTION 01 91 00 - COMMISSIONING

3. CA Review: Prior to substantial completion, the CA shall review the O&M manuals, documentation and redline as built for systems that were commissioned and list other systems documentation that the CA should review to verify compliance with the Specifications. The CA will communicate deficiencies in the manuals to the PM or A/E, as requested. Upon a successful review of the corrections, the CA recommends approval and acceptance of these sections of the O&M manuals to the PM or A/E. The CA also reviews each equipment warranty and verifies that all requirements to keep the warranty valid are clearly stated. This work does not supersede the A/E's review of the O&M manuals according to the A/E's contract.

Cx Record in O&M Manuals:

4. The CA is responsible for compiling, organizing, and indexing all Cx data by equipment into labeled, indexed and tabbed, three-ring binders and delivering them to the CM/GC, to be included with the O&M manuals. Three (3) copies of the manuals will be provided.
5. Other documentation will be retained by the CA.

1.15 TRAINING OF OWNER PERSONNEL

The CM/GC shall be responsible for training coordination and scheduling and ultimately for ensuring that training is complete.

The CA shall be responsible for overseeing and approving the conduct and adequacy of the training of Owner personnel for commissioned equipment.

1. The CA shall interview the facility manager and lead engineer to determine the special needs and areas where training will be most valuable. The Owner and CA shall decide how rigorous the training should be for. The CA shall communicate the results to the Subs and vendors who have training responsibilities.
2. In addition to these general requirements, the specific training requirements of Owner personnel by Subs and vendors is specified in Division 23 and 26 and list other sections where training requirements are found.
3. Each Subcontractor and vendor responsible for training will submit a written training plan to the CA for review and approval prior to training. The plan will cover the following elements:
 - a. Equipment (included in training).
 - b. Intended audience.
 - c. Location of training.
 - d. Objectives.
 - e. Subjects covered (description, duration of discussion, special methods, etc.).
 - f. Duration of training on each subject.
 - g. Instructor for each subject.
 - h. Methods (classroom lecture, video, site walk-through, actual operational demonstrations, written handouts, etc.).
 - i. Instructor and qualifications.
4. For the primary HVAC equipment, the Controls Contractor shall provide a short discussion of the control of the equipment during the mechanical or electrical training conducted by others.

SECTION 01 91 00 - COMMISSIONING

5. The CA develops an overall training plan and coordinates and schedules, with the PM and CM/GC, the overall training for the commissioned systems. The CA develops criteria for determining that the training was satisfactorily completed, including attending some of the training, etc. The CA recommends approval of the training to the PM using a standard form. The PM also signs the approval form.
6. At one of the training sessions, the CA discusses the use of the blank functional test forms for the re-Cx equipment.
7. At the first training session, the mechanical design engineer will present the overall system design concept and the design concept of each equipment section. This presentation shall be one hour in length and include a review of all systems using the simplified system schematics (one-line drawings) including chilled water systems, condenser water or heat rejection systems, heating systems, and gas supply systems, supply air systems, exhaust systems and outside air strategies.

1.16 DEFERRED TESTING

Unforeseen Deferred Tests: If any check or test cannot be completed due to the building structure, required occupancy condition or other deficiency, execution of checklists and functional testing may be delayed upon approval by the PM. These tests will be conducted in the same manner as the seasonal tests as soon as possible. Services of necessary parties will be negotiated.

Seasonal Testing: During the warranty period, seasonal testing (test delayed until weather conditions are closer to the system's design) specified in other sections of the specifications (e.g. Testing and Balancing) shall be completed as part of this contract. The CA shall coordinate this activity. Tests will be executed, documented and deficiencies corrected by the appropriate Subs, with facilities staff and the CA witnessing. Any final adjustments to the O&M manuals and as-builts due to the testing will be made.

END OF SECTION

SECTION 01 35 13 - PERMIT FOR CUTTING AND WELDING WITH PORTABLE GAS OR ARC EQUIPMENT**Part 1 – General****Part 2 – Products****Part 3 – Execution****3.01 Permit for Cutting and Welding with Portable Gas or Arc Equipment**

1. The outside Contractor or Construction Manager is responsible to Vanderbilt's Project Manager for seeing that all cutting, soldering, or welding with portable gas or arc equipment is performed safely and in accordance with NFPA 51B. All such work in occupied buildings must be scheduled in advance with the Construction Manager's Project Manager or Field Superintendent, using the Vanderbilt University Permit. The Field Superintendent shall maintain these permits on file at the jobsite, confirm that the required procedures are followed, and complete the checklist and final check-up, as outlined on the form. Jobsites are subject to unannounced inspections by representatives of Vanderbilt Environmental Health and Safety (VEHS). Upon discovery of violations they are empowered to temporarily close the jobsite until corrective measures are taken.
2. A copy of the Permit (see following page) is included in these standards and is also available through the Vanderbilt Campus Planning website.

HOT WORK PERMIT

STOP!
 Avoid hot work when possible! Consider using an alternative cold work method.

This Hot Work Permit is required for any temporary operation involving open flames or producing heat and/or sparks conducted outside a Hot Work Designated Area. This includes, but is not limited to: brazing, cutting, grinding, soldering, torch-applied roofing and welding.

Instructions for Permit Authorizer	Part 1	Required Precautions
<ol style="list-style-type: none"> 1. Specify the precautions to take. 2. Fill out and keep Part 1 during the hot work process. 3. Issue Part 2 to the person doing the job. 4. Keep Part 2 on file for future reference, including signed confirmation that the post-work fire watch and monitoring have been completed. 5. Sign off the final check on Part 2. 	1. The fire pump is in operation and switched to automatic. Control valves to water supply for sprinkler system are open. Firefighters are in service/operable. Hot work equipment is in good working condition.	<div style="border: 1px solid black; height: 100px; width: 100%;"></div> <p>Requirements within 35 ft. (10 m) of hot work</p> <ul style="list-style-type: none"> Shield combustible construction using listed (e.g., FM Approved) welding pads, blankets and curtains. Remove or shield nonremovable combustibles using listed (e.g., FM Approved) welding pads, blankets and curtains. Isolate potential sources of flammable gas, ignitable liquid or combustible dust/fine (e.g., shut down equipment). Remove ignitable liquid, combustible dust/fine and combustible residues. Shut down ventilation and conveying systems. Remove combustibles and consider a second fire watch on opposite side of floor, wall, ceiling or roof when openings exist or thermally conductive materials pass through. Is work on a combustible building assembly (e.g., Torch-Applied Roofing)? If yes, provide ADDITIONAL REQUIRED PRECAUTIONS below. <p>Hot work on/in closed equipment, ductwork or piping</p> <ul style="list-style-type: none"> Isolate equipment from service. Remove ignitable liquid and purge flammable gas/liquid. Prior to work, and/or during work, monitor for flammable gas/liquid (LFL, re-ignition). Remove combustible dust/fine or other combustible materials. Is work on equipment with nonremovable combustible linings or parts? If yes, provide ADDITIONAL REQUIRED PRECAUTIONS below. <p>Fire watch/fire monitoring the hot work area</p> <p>Does listed site sufficient for majority (Use Table at back of permit for guidance) for combustible concealed cavities, roof work or flammable factors.</p> <ul style="list-style-type: none"> Perform a continuous fire watch during hot work. Perform a continuous fire watch post-work for <ul style="list-style-type: none"> 1 hour or Other ____ hours. Perform fire monitoring for <ul style="list-style-type: none"> 3 hours or Other ____ hours. <p>ADDITIONAL REQUIRED PRECAUTIONS:</p> <hr/> <hr/> <hr/> <hr/>
HOT WORK BY <input type="checkbox"/> Employee <input type="checkbox"/> Contractor _____		
DATE _____ JOB NUMBER _____		
LOCATION OF WORK (BUILDING/ROOM/OBJECT) _____		
WORK TO BE PERFORMED _____		
NAME OF PERSON PERFORMING HOT WORK _____		
NAME OF PERSON PERFORMING FIRE WATCH _____		
I verify the above location has been assessed, the Required Precautions have been taken, and permission is authorized for this work.		
PERMIT AUTHORIZER (PRINT AND SIGN) _____		
THIS PERMIT EXPIRES ON (LIMIT AUTHORIZATION TO ONE SHIFT):		
DATE _____ TIME _____ AM/PM _____		
Note: Emergency notification on back of form.		
<p>Additional FM Global Resources: Property Loss Prevention Data Sheet 10-1, Hot Work Management Hot Work Permit App via fmglobal.com/app Hot Work Permit form # 2630 via fmglobal.com Online training at training.fmglobal.com FM Approved equipment via fmapproved.com</p>		
1990 © 2019 FM Global 01/2019. All rights reserved.		

END OF SECTION -

SECTION 01 51 00 - TEMPORARY UTILITIES**Part 1 – General****Part 2 – Products****Part 3 - Execution****3.01 Utility Shut-Downs**

All utility shut-downs affecting University facilities outside the construction project shall be scheduled through the Project Manager. A ten-day notice is required. Utility interruptions should generally be scheduled to occur during non-business hours. See attached sheet in this section for typical form to be utilized.

3.02 Temporary Lighting

The Contractor shall provide temporary lighting for construction projects to ensure that all areas affected by construction shall be lit to a level commensurate with the surrounding campus environment.

3.03 Utility Cost Recovery

The Contractor is expected to include in construction the applicable cost of all utilities.

3.04 Major Construction

1. During frame construction and closing-in the building, the Contractor should include in construction cost; utilities for temporary electricity, heat, and water. It is the Contractor's responsibility to obtain the metered services from the appropriate utility company and pay all costs associated with these temporary services.
2. After the building is closed-in, it is generally in the best interests of the University to provide steam and electricity from the Steam Plant and/or University substation if these are the permanent sources. Permanent metering acceptable to Plant Operations needs to be provided by the Contractor before connecting to the University's steam or electric system. Charges will be made for actual usage at current rates. Vanderbilt Plant Operations staff will be responsible for reading the steam and/or electric meter. Payments will be coordinated through the Project Manager.
3. Where a new project has a direct Nashville Electric Service (NES) permanent electrical service or a stand-alone heating system, the Contractor is responsible for all utility expenses until the Project is accepted for occupancy by Vanderbilt.

3.05 Renovation Projects

Where work is performed in existing buildings and it is directly metered, the procedures outlined above will apply. Where utility costs cannot be isolated or independently metered, the Project Manager will advise the contractor on how utility costs are to be recovered.

-END OF SECTION -

SECTION 01 55 00 - ACCESS ROADS AND PARKING**Part 1 General****1.01 Scope**

The Contract Documents are to instruct the Contractor to establish and coordinate all construction-related parking arrangements through Parking Services.

Part 2 Products**Part 3 Execution**

1. General parameters include assurances that no personal vehicles are allowed within construction site, and that all requirements of the Parking Services for permitting, etc. are met and remain current in compliance.
2. The Designer shall determine with the Project Manager and Contractor, when possible, the acceptable access routes to and from a project and parking arrangements. These shall be noted in Contract Documents and on the Site Use Map whenever feasible.

END OF SECTION -

SECTION 01 56 00 - TEMPORARY BARRIERS**Part 1 - General****1.01 Scope**

All barrier types and locations must be reviewed with and approved by Project Manager.

Part 2 – Products**Part 3 – Execution****3.01 Fences**

1. All projects of duration greater than one normal working day, that require outdoor staging, excavation, or disturbance to any existing exterior conditions must be enclosed with chain link fencing six (6) feet high and use pipe-frame gates covered in chain link. Where driving posts into the ground is not practical, pipe framed bases (field fencing) weighed to enhance stability may be substituted. This method of constructing chain link fencing must be approved in advance by the Project Manager. Any excavation required beyond the enclosed site limits lasting longer than one normal working day must be fenced as noted above.
2. Excavations and open utilities that can be completed within one normal working day require enclosing in field fencing as described above.

3.02 Gate Keying

1. Gates will be padlocked with all locks keyed alike on each project. One key will be given to the Project Manager and one to Plant Operations Key Shop.

3.03 Tree and Plant Protection

1. Landscape areas and trees designated for protection on the Site Use Map will be field inspected by Project Manager and/or University Landscape Architect and Contractor prior to site mobilization to determine actual barrier locations. Six (6) foot high chain link fences on driven metal posts are typically used. See also section 32 01 90.33. Care should be taken when driving metal posts as to not hit irrigation or other buried conduit. Underground utility locating company are required to define all underground utility locations.

3.04 Barricades

1. Any excavation, trenching deeper than 2 inches, open utility, etc., regardless of duration or depth that cannot reasonably be fenced must be posted at all times with blinking light barricades at all approaches.

END OF SECTION –

SECTION 01 70 00 - PROJECT CLOSEOUT**Part 1 – General****Part 1 Scope**

Successful Closeout of a major project requires close cooperation of the Designer, Contractor, and Vanderbilt University. It is the responsibility of the Designer to take a leading role in the process to ensure that appropriate requirements are included in the Contract Documents; that submittals and record documents are transmitted and organized.

Part 2 – Products**Part 3 – Execution****3.01 Record Document Submittals**

The Designer and Contractor shall share responsibility for production of the following record documents:

1. Record Drawings – The Contractor shall be required to provide a set of Contract Documents, in undamaged condition, with mark-up of actual installations which vary substantially from the work as originally shown. The mark-up's need to indicate new information which is recognized to be of importance to Vanderbilt University. Give particular attention to concealed work which would be difficult to measure and record at a later date. Note related change order numbers where applicable.
2. Line Drawings – Provide CAD files of floor plans that indicate all “as-built” walls and structure, Vanderbilt-approved room numbers, gross square footage per floor, north arrow, and graphic scale. Final product to adhere in format and style to existing “Line Drawings” presently maintained at the Space and Facility Information Center, Room 106, Bryan Building. All questions as to proper scale of drawings, etc. to be directed to Manager of the Center.
3. Product Data Submittals – Provide one (1) copy of each Shop Drawing and product data submittal and mark-up significant variations in actual work in comparison with submitted information. Shop drawings are to be organized and collated using standard CSI format.
4. Operating & Maintenance Manuals - Provide organized and comprehensive digital Operating-and-Maintenance Manuals. Include emergency instructions, spare parts listing, wiring diagrams, recommended "turn-around" cycles, inspection procedures, shop drawings, product data and similar applicable information.
5. The manual shall include all warranties, bonds, final certificates, and other similar documents. Furnish an index which outlines all work covered by specific warranties identifying the item, the length of the warranty, and the contractor responsible for the warranty.
6. For new buildings and major renovations, the Designer shall provide a Finishes Manual which outlines the brand name, manufacturer's number, color, and finishes for the building, such as carpeting, paint, wall finishes, ceilings, casework, light fixtures, hardware, etc. Sufficient information should be provided to serve as a reference source to order similar products for future renovations or replacements. Storage of the finish manual is online at (OFIS button).

SECTION 01 70 000 - PROJECT CLOSEOUT**3.02 Operating & Maintenance Instruction**

For new building and major renovations the Designer and Contractor shall share responsibilities for coordinating the initial operating demonstrations. The Designer and Contractor shall arrange for training sessions with Vanderbilt for each major installation of work requiring training in operation and maintenance procedures. These training sessions shall include:

1. Review of manufacturer's instructions, operating and maintenance manuals, control sequences, hazards, and other similar procedures.
2. Demonstrate equipment start-up, shut-down, emergency operations, noise and vibration adjustments, safety features, economy/efficiency adjustments, and similar operations.
3. Review applicable warranties, bonds, maintenance agreements, and other similar commitments as they relate to ongoing maintenance.

3.03 Final Clean-Up

The Contractor shall at completion of each contract prior to final inspection, thoroughly clean the project, the site(s) occupied, leaving interior spaces broom clean and exterior areas fine graded, clean and free of all debris, papers, discarded or broken glass, materials, tools, and equipment.



RECORD SET DELIVERABLE REQUIREMENTS

This project has been determined to be substantially complete and ready for financial close out. In order to complete the University's indexing and archiving of this project, Vanderbilt requires the following Record Set deliverables as outlined in the Owner Architect Agreement as executed by the Architect and Vanderbilt.

1. GENERAL NAMING CONVENTION^{*}

Always contact Facility Information Services (FIS) for University and Real Estate buildings or Space and Facilities Planning (SFP) for Medical Center Buildings to confirm the use of the appropriate naming conventions. Please refer to the appropriate naming conventions sections and examples in the Record Set Examples Documentation section of the Closeout Request packet. The general naming convention is as follows:

BLDG # – ARCHITECT PROJECT # – PROJECT SECTION or PHASE # – SHEET #

Building # = Assigned by Vanderbilt and should be verified by FIS or SFP

Architect Project # = the Architect of Record's initiated project number[†] and match exactly character for character.

Project Section or Phase # = A Project Section or Phase number is only to be used when a project is divided into multiple stages (-01, -02, -03). Do not use -00 when the project is unique / individual with no following phases/sections to be completed. Should any additional "side work" be performed and its documents included under the scope of the original project, then no section or phase number is required.

Sheet # = the sheet number assigned by an Architect or Engineering firm. The sheet number is to match the drawing sheet number exactly character for character.

A. **File naming convention:**

BLDG # – ARCHITECT PROJECT # – PROJECT SECTION or PHASE # – SHEET #

The file naming convention shall be used to identify each file, within the directory structure, with the corresponding cad file and corresponding plot file. The file naming convention should be identical to the sheet naming convention and carry the correct file extension for its file type (dwg, dgn, plt, cal).

B. **Sheet naming convention within the drawing sheet/image:** [CAD and plot files]

BLDG # – ARCHITECT PROJECT # – PROJECT SECTION or PHASE # – SHEET #

The sheet naming convention shall be used to identify each drawing sheet/image with the corresponding CAD and plot files. The sheet naming convention shall be electronically embedded and located within or adjacent to the title block. The following shall be electronically embedded and located within or adjacent to the title block in addition to the sheet name:

- Include the term "Record Set"
- Include the term "COSC"[‡] and the date of the Certificate of Substantial Completion (C.O.S.C.) formatted as **Month-Day-Year** (example: 1-15-2010. Note: the year shall be 4 digits)

C. **Digital Manual file naming convention for PDF manuals:**

The Digital manual file naming convention shall be used to identify the pdf of the Closeout manual(s) and/or the pdf of the Project manual(s) within the directory structure.

BLDG # – ARCHITECT PROJECT # – PROJECT SECTION or PHASE # – OM and/or

BLDG # – ARCHITECT PROJECT # – PROJECT SECTION or PHASE # – PM

^{*} Refer to the "Record Documentation Example" for acceptable naming convention examples or contact FIS or SFP to confirm the use of appropriate naming conventions. ie: OM, PM, and drawing file and sheet naming conventions.

[†] Number should be exact as it appears on drawing sheet/image

[‡] Certificate of Substantial Completion Date and must be formatted as **Month-Day-Year** (year is to be 4 digits).

2. COORDINATE SYSTEM

The Tennessee State Plane Coordinate System (FIPSzone 4100); North American Horizontal Datum, NAD 83 (90 Epoch); North American Vertical Datum, NAVD 88 in U.S. feet and inches shall be used for the following drawings:

- A. All Surveys
- B. All drawings containing a building footprint shall be drawn so that at least two points of the building's footprint are referenced to the Tennessee State Plane Coordinate System.
- C. All drawings, containing above ground or underground utilities, shall be drawn so that at least two points of a permanent structure (one that will remain after the construction, preferably the building footprint) are referenced to the Tennessee State Plane Coordinate System.

3. SOURCE MATERIAL

Source material shall be defined as all digital CAD related information deemed to be necessary by the Architect of Record and Project Manager to correctly portray construction of a project. These items shall include but are not limited to:

- Source elements
- Reference drawings
- Font libraries
- Custom line style/codes
- Large graphic files (tiff, jpeg, etc.)

The drawings described above shall be submitted in any of the following three formats:

- AutoCad DWG[§]
- Microstation DGN
- Autocad/Microstation Compatible DXF

Each drawing shall be submitted as a separate CAD file.

Additional CAD file Requirements are:

- A. All External Reference drawings (X-refs) shall be bound or inserted as a permanent part of the CAD drawing.
- B. Any graphics used (jpeg, tiff, bitmap) included in the source folder but are not required to be bound to the CAD file.
- C. Be drawn in model space to a 1 to 1 scale
- D. Contractor Fire Protection and irrigation drawings (if applicable to the project) included in the source material folder
- E. Each CAD file shall include the **sheet naming convention** and the terms "RECORD SET", and "COSC" Date** electronically embedded and located within or adjacent to the title block.
- F. Each CAD file shall include the **file naming convention**

Refer to the "Record Documentation Example" for approved file and sheet naming convention examples or contact FIS or SFP for guidance.

Include contractor Fire Protection and Irrigation CAD files in CAD folder (if applicable to the project).

4. DIGITAL PRINTS (PLOT FILES)

- A. All plot and cal files shall be generated from the original Native Source material.
- B. PLOT files of the RECORD SET drawings shall be submitted in HPGL/2^{††} (HPGL/2 is the preferred format) or CAL file formats with a file extension of PLT, ML, CAL, HPG, or HPGL.
- C. Should the source media be in a non-electronic format, a CALS^{††} file format may be substituted for the HPGL/2 format.
- D. Digital prints shall be at the scale and size of the original bid documents, not to exceed 36" x 48".
- E. Set as layout 1:1 scale
- F. Each PLOT file shall include the **sheet naming convention** and the terms "RECORD SET", and "COSC" Date electronically embedded and located within or adjacent to the title block.

[§] AutoCad DWG (version 2002-2007) is the only format available for submittal to Space and Facilities Planning.

** Certificate of Substantial Completion Date (COSC) and must be formatted as **Month-Day-Year** (year is to be 4 digits).

†† Hewlett Packard Graphic Language version 2. Vector file with raster capabilities.

‡‡ Computer Aided Acquisition and Logistics Support. Bitmap raster file designed by US Dept. of Defense.

- G. Each PLOT file shall include the **file naming convention**

Refer to the "Record Documentation Example" for approved file and sheet naming convention examples or contact FIS or SFP for guidance.

Include contractor Fire Protection and Irrigation Digital files in Digital folder (when applicable to the project).

5. DIGITAL MANUALS

Digital Manuals shall consist of Project Manuals and Closeout Manuals (including but not limited to Operations and Maintenance manuals)

- A. The Project Manual shall be submitted as 1(one) PDF file containing multiple pages with each specification division and section bookmarked. Project Manuals should be submitted with addenda in their original form, no revisions to Project Manual are required.
- B. Closeout Manual shall be submitted as 1 (one) PDF file containing multiple pages with each C.S.I. division and section bookmarked. Refer to the Closeout manual checklist for the required material for this manual.
- C. Digital Manuals shall be text searchable.
- D. Each Digital Manual shall use the Digital Manual file naming convention. Refer to examples in the "Record Documentation Example".
- E. Manuals shall not exceed 250 mb file size. Files larger than 250mb +/- shall be divided into multiple volumes. Refer to examples in the "Record Documentation Example" for Digital manual file naming conventions for multiple volumes or contact FIS at (615) 322-3715 or SFP at (615) 322-4962

6. DELIVERABLE DIGITAL MEDIA

University and Real Estate projects – Deliver one copy of all digital media for the project on a CD-ROM or data DVD to FIS.

Medical Center projects - Deliver two copies of all digital media for the project on a CD-ROM or data DVD to SFP.

- A. The following is required of the CD-ROM(s) or data DVD(s):
 - I. The file structure^{§§} of the CD-ROM(s) or data DVD(s) shall be:
 - One folder labeled "CAD FILES" (to contain source drawings/drawing files)
 - One Sub-folder within the "CAD FILES" folder, labeled "SOURCE MATERIAL****" (to contain all the CAD source related material including but not limited to Font libraries and Custom line style/code)
 - One folder labeled "PLOT FILES" (to contain the digital prints/Plot files)
 - Pdf of the Project manual and labeled according to the file naming convention (no folder is necessary)
 - Pdf of the Closeout manual and labeled according to the file naming convention (no folder is necessary)
 - II. Zip files or any other type of compression files are not permitted for any category of deliverable.
 - III. Separate CD's are not accepted for each category of deliverable. All digital items (ie: source material, digital prints, and digital manuals) should be inclusive of one disk.
- B. The CD-ROM(s) or data DVD(s) and the hard holding case(s) (jewel case) both shall be labeled with the following:
 - RECORD SET
 - COSC Date
 - Official project name
 - Official project number
 - Disk 1 of 1^{†††}

Contact FIS to send test examples for each project for approval, prior to submitting records.

Please contact the following with questions or comments:

Facilities Information Services Library at (615) 322-2715 or Space and Facilities Planning at (615) 322-4962.

^{§§} Refer to the Record Set documentation examples for approved options for the CD file structure

^{****} Files that may be needed for a true visual reproduction of the drawing as seen and drawn by the originating firm or designer and may cause a loss of design intent if not used.

^{†††} Contact FIS or SFP if more than one disk is needed for a project

SECTION 01 91 00 - COMMISSIONING**PRODUCTS:**

The contractor shall provide all testing equipment required to perform startup, pre-functional tests, and functional tests. All testing equipment must have sufficient quality and accuracy to test or measure performances within tolerances contained in the project manual specifications. If not noted, temperature sensors and thermometers shall have a resolution of +/- 0.1 Deg-F; pressure gauges +/- 2.0% of the value range measured.

EXECUTION:

The A/E will define the full scope of CX work including the commissioning plan details and specify start-up pre-functional checklists and functional testing expectations.

The CM and the Owner will establish meeting schedules with all contractors, vendors, etc starting with presentation of the CX plan to establish milestones and lines of communication and responsibility.

The CA will make periodic site visits, witness duct pressure testing and pipe flushing and pressure testing, randomly witness pre-functional start-up and testing and report findings to the Owner and the CM for resolution.

At the completion of TAB field work, the CA will conduct random TAB report verification of 20% of the final TAB data. If more than 10% exceed the contract specification allowance, retesting a portion or all of a specific HVAC system will be required at the expense of the TAB agency.

Instruct the CM to have delivered the following to the CA prior to the functional performance testing (FPT):

- All submittals, and control logic in particular
- Published O&M manuals
- Final TAB reports or drafts of field data
- Arrange for the controls contractor to be on site along with all applicable sub-contractors and coordinate testing dates with the VU Project Manager, Plant Operations, and BSC.

Instruct the CM and sub-contractors to operate all equipment and systems for the functional performance testing (FPT) in accordance with the CX plan. As a minimum, the FPT shall include the following 'acceptance checklist':

Mechanical:

- ✓ Visually inspect all steam, chilled water, hot water or refrigerant piping, piping insulation, and pipe hangers.
- ✓ Verify that piping configurations, heat exchangers, and coils piped in the counter-flow configurations, drains, traps, and valves are accessible, serviceable and functional.
- ✓ Verify appropriate access for all serviceable components such as belts, bearings, motors, and filters.
- ✓ Visually inspect drivers, belts, access covers, guards, and enclosures. Fan belts and sheaves and pumps are to be properly aligned and tensioned without noticeable vibration.
- ✓ Verify all seals and gaskets are undamaged and all mating surfaces meet to provide to ensure unit integrity.

SECTION 01 91 00 - COMMISSIONING

Controls:

- ✓ Verify that all control devices such as dampers and valves cycle freely without binding throughout the full operating range of the device.
- ✓ Simulate safety shut-down conditions and verify that safety devices function as designed to protect the equipment, system, or devices from catastrophic failure.
- ✓ Verify both the normal and emergency sequences of operation. Simulate operating parameters which cause the unit or system components to cycle, modulate or change position.
- ✓ While operational verify the equipment, systems, or devices operate to achieve and maintain designed set-points.
- ✓ Verify that graphics on front-end computers comply with Building Systems Control (BSC) standards including the display of actual and set-point values, supporting parameters such as secondary water supply temperature, pump status, outside-air conditions, calculated resets, flows, valve positions, static pressure, etc.
- ✓ Lighting & Lighting controls – the commissioning agent must verify the Bacnet coordination between the lighting control and BAS systems in order to facilitate coordinated occupancy and scheduled setback control of both lighting and HVAC.
- ✓ Witness startup and functional testing of variable frequency drives (VFD) including ramping parameters, fault management, minimum programmed speed, test operation with key pad and verification of the auto signal response.
- ✓ Verify metered chilled water, hot water, steam, domestic water and gas (as applicable) are connected and trending in the BAS.

Electrical:

- ✓ Visually inspect wiring, wire size, disconnect device, terminations, and conduit runs.
- ✓ Inspect conduit pathways for conflicts with junction box covers or equipment service access points.
- ✓ Witness or conduct function and acceptance testing for all transformers, switchgear and related equipment.
- ✓ Verify circuit and breaker information on equipment.

Working with the Owner, the CM will administer and manage the deficiency (or action item) list.

END OF SECTION-

SECTION 02 41 13 - SELECTIVE SITE DEMOLITION**Part 1 – General****1.01 Scope**

Removal and disposal of designated foundations, pavements, concrete, curbs, culverts, utilities and other structures.

1.02 Related Work

1. Section 31 11 00: Clearing and Grubbing
2. Section 31 23 00: Excavation and Fill

1.03 Quality Assurance

1. Contractor Qualifications: Minimum of 5 years of experience in demolition of comparable structures.
2. Comply with requirements of codes.
3. Comply with requirements of local Public Health Authority.
4. Comply with local utility companies and/or utility districts.

1.04 Submittals

1. Certificates of severance of utility services.
2. Permit for transport and disposal of debris.
3. Demolition procedures and operational sequence for review by Owner's Representative.

1.05 Job Conditions**A. Protection:**

1. Erect barriers, fences, guard rails, enclosures, chutes, and shoring to protect structures and utilities remaining intact. See 01 56 00.
2. Protect designated trees and plants from damage, as directed by the University Landscape Architect.

B. Maintaining Traffic

1. Ensure minimum interference with roads, street, driveways, sidewalks, and adjacent facilities.
2. Do not close or obstruct streets, sidewalks, alleys, or passageways without permission from authorities having jurisdiction.
3. If required by governing authorities, provide alternate routes around closed or obstructed traffic ways.

SECTION 02 41 13 - SELECTIVE SITE DEMOLITION**Part 2 - Products****Part 3 - Execution****3.01 Preparation**

1. Prepare adjacent areas to prevent injury, movement or settlement of structures which are to remain.
2. Arrange for, and verify termination of utility services to include removing meters and capping lines.
3. Remove items scheduled to be salvaged for Owner, and place in designated storage area.

3.02 Demolition

1. Remove concrete pavement, base, curbs, gutters, sidewalks, driveways, etc. and dispose of them as follows:
 - a. Dispose of items which are not more than two feet below subgrade elevation.
 - b. Follow strategies in the SBS (Appendix A) for diversion and reuse where possible.
2. Break items more than two feet below subgrade elevation into sizes not-to-exceed twelve inches in maximum dimension and leave in place, unless it interferes with succeeding items of construction.
3. Stockpile ballast, gravel other pavement materials when required.
 - a. Coordinate removal and relocation of power poles, street lighting, telephone lines and site lighting, with the local electric utility.
 - b. Remove existing water services, sanitary sewer and storm drainage pipe and structures as indicated and as necessary to facilitate new construction.
 - c. Remove old foundations, cisterns, etc., which maybe encountered within the building area.

3.03 Debris Removal

1. Promptly remove demolition debris from site. Follow the SBS (Appendix A) for specific requirements on proper diversion of demolition debris.
2. Contractor is required to determine alternatives to landfilling or sending C&D waste to a waste disposal facility. Once all efforts to divert waste to the 75% required level have been made, remaining waste shall be disposed of only after obtaining permission from applicable regulatory authority for disposal of debris to waste disposal plant.
3. Do not store or burn materials on site.

END OF SECTION -

SECTION 03 00 00 - CONCRETE

Part 1 - General

1. All concrete slabs with floor drains shall have positive slope to drain.
2. See section 32 13 13 Concrete Walks and Paving for information on exposed aggregate or sandblasted finish concrete walks and paving.
3. Refer to section 09 00 00 Finishes for further information on Mechanical Room floor finishes.

Part 2 – Products

Part 3 – Execution

END OF SECTION -

SECTION 04 00 00 - MASONRY**Part 1 – General****1.01 Scope**

Vanderbilt University will participate in the selection and approval of all exterior masonry finishes.

Part 2 – Products**Part 3 - Execution****3.01 Mock-up Panels**

1. Mock-up panels of all masonry used on the exterior of a project, shall be specified. Exact requirements are a function of the project size and shall be reviewed with Project Manager. Mock up panels should include all elements of the wall including flashing, mortar net, weeps, thermal insulation, damp-proofing or weather barrier. Mock-up panels should be built in the same location as the project so site conditions are mimicked.

3.02 Unit Masonry

1. Review weeps design with Project Manager. Generally the new weeps should match the existing weeps on the building. The University has had success with open head joints, rope and plastic insert grid. Color to be approved by the Project Manager.
2. Mortar Net shall be included as part of a typical exterior wall section.
3. The Designer and Owner shall review and approve the color of all caulking used on horizontal and vertical joints in the masonry. Generally vertical joints should match the masonry and horizontal joints should match the mortar.
4. Expansion Joints - Designer shall indicate location of all expansion joints on plans and elevations in both brick and CMU.
5. Dry cutting of masonry units is prohibited. A wet saw is to be used in designated areas only. Confirm location with Project Manager before any and all cutting.

3.03 Mortar Coloring

1. The Designer should note that buff color mortar is generally used; exact color depends on brick or stone used. Designer shall review and receive approval of proposed brick or stone AND mortar color through the Project Manager.

END OF SECTION-

SECTION 05 00 00 - METALS**Part 1 – General****Part 2 – Products****Part 3 – Execution****3.01 Metal Materials & Method**

1. All exposed exterior masonry lintels must be galvanized. Except at exterior exposed lintels in masonry partitions the use of galvanized metal that must be painted on the exterior of the building is not recommended. If galvanized metal is used it must be properly prepared to receive paint.
2. Exterior steel handrails, guardrails and stanchion posts must be primed with two coats of a rust inhibiting primer before receiving the first color coat. The primer should be specified to be one that is recommended by the manufacturer of the finish coat. Specify that the entire length of the stanchion post, including that part to be anchored in substrate, must be primed and painted with two color finish coats prior to installation.
3. All rails at sidewalks and at stairs shall be steel and painted black, unless otherwise approved by the Project Manager.
4. Exterior steel stanchion posts that support handrails and guardrails must be anchored so that they do not crack or split the material into which they are set. When steel stanchion posts are grouted into concrete, stone or masonry, there shall be a minimum of ½” of exterior expansion joint sealant covering the grouted anchor attachment. Sealant shall be installed to completely cover the grout and provide positive drainage away from the stanchion post stems. Standing water adjacent to stanchion posts is not acceptable.

END OF SECTION-

SECTION 06 00 00 - WOOD AND PLASTIC

Part 1 – General**Part 2 – Products****Part 3 – Execution****3.01 Rough Carpentry**

1. Wood or metal blocking shall be specified in all new partitions designed to support, reinforce, or secure handicapped door operators (minimum 10" high, width to match frame) shelving, door stops, wall mounted coat racks, toilet accessories, markerboards, chalkboards, wall mounted cabinets, etc.

3.02 Finish Carpentry

1. All work under this section shall be "Premium Grade" as defined by the Quality Standards of the Architectural Woodwork Institute unless otherwise instructed by Campus Planning.
2. The use of redwood should be avoided.
3. The use of particle board shelving should be avoided.
4. Only "Heavy Duty" brackets and supports should be specified for wood shelving. Shelving shall be 3/4" minimum thick with support spacing a maximum of 2'-0" o.c.
5. Base cabinets below sinks in labs, kitchens, bathrooms, laundries, etc. shall be constructed of marine grade plywood. Adjacent cabinets may be constructed of exterior grade plywood, but particle board and MDF board are not acceptable in base cabinets in any "wet" room locations.
6. Wood or metal blocking is required to be installed between studs for shelving, upper cabinets, etc. where loading of the shelf or cabinet is a concern.

3.03 FM Global Requirements

1. Materials used for construction should be, in order of preference, noncombustible, FM Approved or Class 1. FM Approved products are all marked with the FM APPROVAL mark. This includes but is not limited to plastic construction materials and insulations, ducts, pipes, etc. The *Approval Guide*, a publication of FM Approvals, may be referenced at www.approvalguide.com.
2. Insulated metal panel walls should be FM Approved and installed in accordance with FM Global Property Loss Prevention Data Sheet 1-57, *Plastics in Construction*.
3. Composite panels should not be used in new construction as there are no FM Approved composite panels. If their usage is unavoidable, utilize metal composite panels (MCM & ACM, aluminum composite panels) that have passed a large scale fire test such as FM 4880 or NFPA 285, *Standard Fire Test Method for Evaluation of Fire Propagation Characteristics of Exterior Non-Load-Bearing Wall Assemblies Containing Combustible Components*. Install panels provided with a fiber or similar non-combustible core material. Plastic core materials such as polyethylene or polystyrene should not be considered due to the high combustibility of the material.
4. Exterior insulation and finish systems (EIFS) are no longer FM Approved and are not recommended for new construction. EIFS may be subject to moisture penetration and

mechanical impact damage and typically contain combustible components.

-END OF SECTION-

SECTION 07 00 00 - THERMAL AND MOISTURE PROTECTION**Part 1 – General****1.01 Scope**

As a long term owner Vanderbilt University is interested in having the thermal and moisture protection design in each building to have as long a life as possible.

Part 2 – Products**2.01 Membrane Roofing**

1. Membrane roofing shall be fully adhered and shall have a minimum thickness of 0.60 mils with fleece backing.
2. Loose laid membrane roofing and ballasted roofing are not allowed.
3. EPDM, TPO, PVC and KEE are acceptable membrane roof types.

2.02 Metal Roofing

Metal roofing should be standing seam copper, stainless steel or aluminum.

2.03 Walk Pads

Walk pads are required on flat roofs and should extend from the point of roof access to and around any and all mechanical equipment that will need to be serviced.

2.04 Gutters and Downspouts

1. Gutter and downspouts should be copper or aluminum on Academic buildings and are to be reviewed with Project Manager.
2. Provide roof and grade splash guards at each downspout.

2.05 Tie Offs

Projects with steeply sloped roofs will need to provide a means for Plant Operations to tie off in order to safely maintain the building.

2.06 Warranty

A minimum 20 year warranty is required for all new roofs.

2.07 Ductwork and Piping

1. Supply-air ductwork mounted on or above roofing is not allowed. Exhaust-air ductwork on or above roofing is acceptable only where other means of exhaust are impractical.
2. Roof mounted piping is acceptable only where no other solution is practical.

SECTION 07 00 00 - THERMAL AND MOISTURE PROTECTION

3. Shop drawings are to be submitted to the Project Manager for review.

2.08 Roof Insulation

1. Preferred insulation is poly iso with staggered joints under the fully adhered membrane.
2. Where tapered insulation is used a tapered insulation plan is required and should be approved by the Project Manager before insulation is delivered to the site.

2.09 Building Envelope Requirements

Minimum recommended R Values for the building envelope are:

1. Roof R-30
2. Walls R-19
3. Crawl Spaces R-19
4. Also see window requirements in Design Concepts 00 80 00

*care should be taken to design building envelopes and mechanical systems as to not generate conditions which create mold and condensation.

Part 3 – Execution

1. Review roofing system with Project Manager prior to completion of documents.
2. An inspection of the roof by the roof membrane manufacturer is required on all single-ply membrane roofs.
3. For design purposes, the following criteria should be used for roofing components and wall cladding systems for new buildings at Vanderbilt University Campus:
 - a. 1.15 Wind Importance Factor (for cladding)
 - b. Ground Roughness C
 - c. 90 mph Wind Speed (ASCE 7)
 - d. 10 psf Ground Snow Load
 - e. 3.5 in./hr. Rainfall Intensity
4. To maintain the proper fire and wind uplift pressure ratings, new roof systems should be FM Approved and designed in accordance with the guidelines detailed in *RoofNav* and the latest issues of FM Global Property Loss Prevention Data Sheets 1-28, *Wind Design*, and 1-29, *Roof Deck Securement and Above-Deck Roof Components*.
5. Please have the installing contractor complete the attached FM Global Form X-2688, *Checklist for Roofing System*, as well as a Contractor's Package from RoofNav for each roof area and submit them to FM Global for review and acceptance prior to installation. RoofNav can be accessed at www.RoofNav.com.
6. Frequently, the best avenue for obtaining a RoofNav Assembly Number is to contact the roofing manufacturer's code or standards engineer. RoofNav is a unique password-protected application that is accessible without charge at www.RoofNav.com. The RoofNav application allows members access to the roof-specific portions of the FM Approvals' Approval Guide through a series of tools

and comprehensive search capabilities. With RoofNav, roofing professionals can search a massive database to create a contractor package that meets both FM Approval requirements and customer specifications. RoofNav effectively simplifies the process of configuring and installing roofing assemblies that meet the requirements of FM Approvals.

7. There should be no component substitutions or deviations from the proposed RoofNav assembly. Use of individually FM Approved components, not FM Approved for use together does not constitute an FM Approved or recommended assembly. All FM Approved materials are *required* to have the FM APPROVAL mark on the packaging or the material itself. Materials without proper labeling are not FM Approved. If alternatives are desired, a different RoofNav assembly should be chosen and submitted for review.
8. Roof edge flashing should be FM Approved for the design wind uplift rating and installed in accordance with FM Global Property Loss Prevention Data Sheet 1-49, *Perimeter Flashing*. FM Approved perimeter flashing systems can be found at www.RoofNav.com. Flashing systems should be factory fabricated and not fabricated on site where possible.
9. Design all roofs with positive drainage. Roofs should be sloped at a minimum rate of ¼ in. per 1 ft (2%) toward roof drains or scuppers or points of free drainage (roof edge). If a design roof slope less than ¼ in. per 1 ft. is desired, the roof framing designer should prepare and submit to FM Global calculations according to FM Global Property Loss Prevention Data Sheet 1-54, *Roof Loads for New Construction*, or other appropriate method, to substantiate that the design slope is sufficient to prevent roof instability due to ponding.
10. Design drainage in accordance with Data Sheet 1-54, *Roof Loads for New Construction*. Provide secondary (overflow or emergency) roof drains or scuppers where blockage of the primary drains, if any, allows water to accumulate. This includes when roof gutters or other drains are located behind a parapet.
11. Any roof elevation change ≥ 3 ft. between buildings may result in increased snow loading due to drifted snow. In this case, the lower roof should be designed to withstand this increased load, and details of this design should be forwarded to FM Global for review and acceptance prior to construction.

END OF SECTION -

SECTION 07 60 00 - FLASHING AND SHEET METAL**Part 1 – General****1.01 Scope**

Flashing is a critical component of any construction project. The designer shall ensure that details correctly depict positive fall for drainage. Weeps, flashing and counter flashing shall slope away from the wall.

Part 2 – Products**Flashing**

1. Stainless steel is the preferred flashing material. Other flashing materials such as copper fabric, self-adhered bitumen and EPDM may also be utilized.
2. Ice and water shield should be used in strategic areas as a roofing underlayment
3. No flashing exposed to sunlight shall be asphalt based due to UV sensitivity.
4. Provide end dams at window openings. All joints in metal shall have either mitered joints or be properly lapped and sealed or soldered at inside and outside corners.

Part 3 – Execution

1. Stainless steel flashing must have 2” lap joints with fully soldered joints. For long runs over 20 feet, provide 6” expansion joints with 3 strips of double sided sealant tape the entire width of the flashing.
2. Peel and stick flashing must be terminated at the top of the through wall flashing, with a termination bar, and have a stainless steel drip edge since it must be held back one half inch minimum from the face of the brick. Through wall flashing shall not be cut back within the cores of the brick. The Designer shall review the installation prior to the Contractor trimming the flashing flush with the brick.
3. Through wall flashing in cavity walls shall be the full width of the brick and turn up in the back. Flashing shall be turned behind the sheathing on framed walls and into the mortar joints on CMU walls. The flashing shall extend a minimum of 8” up in the cavity.
4. Provide two-piece flashing to facilitate reroofing and allow for tolerance in construction.
5. Counter flashing in masonry shall be inserted into a reglet joint and sealed with a polyurethane sealant. (Refer to SMACNA figure 4-3B (1995)).
6. Through wall flashing shall be run continuous through control joints. Provide for expansion by lapping sections a minimum of 6” and seal with three rows of sealant. Expansion should be provided at wall joints and at twenty feet on center.
7. Through wall flashing should be located 8” minimum above finished roof surfaces.

SECTION 07 60 00 - FLASHING AND SHEET METAL

8. Sill flashing should extend from the inside face of the window beyond the outside face. Edge and sides of flashing should be turned back to form end dams at least 1" in height. The sill flashing should be set in a continuous bed of sealant with any fasteners that penetrate the sill flashing completely sealed.
9. Through wall flashing shall be installed above and below all window and door openings.
10. All windows shall have sub sills with back dams and end dams.
11. Through-wall flashing is required below the cap of all exterior site walls and columns.

END OF SECTION -

SECTION 08 00 00 - DOORS AND DOOR HARDWARE

Part 1 - General

Guidelines for doors and door hardware on the Vanderbilt University campus. Doors and door hardware shall comply with the version year adopted by the Authority Having Jurisdiction (AHJ) and follow industry standards.

Part 2 - Products

2.01 Doors

1. In general, interior doors will be solid core wood, faced in wood veneer to match adjacent existing doors. No plastic faced doors will be used without special permission. Hollow metal doors and aluminum storefront doors are preferred in some applications. Stile and rail panel doors may be used if reviewed and authorized by the Project Manager.
2. Wood species for exterior wood doors should be Mahogany, or White Oak. Designer will specify two coats of alkyd based primer prior to two finish coats on all exterior wood doors.
3. Aluminum or aluminum and glass doors are preferable to wood exterior doors. Wood doors must be covered and approved in advance by the Project Manager.
4. Painted hollow metal doors are preferable to wood exterior doors at minor building entrances.

2.02 Hardware

1. All locksets shall be one of two varieties, mortise or cylindrical. The Designer will recommend a variety and receive the Project Manager's authorization before writing final specification. Locksets will be Best, Yale or Marks. The Designer will review the function of locksets with the Project Manager prior to final specification. In general, preferred units are as follows:

Mortise Locksets:	Yale	8800
	Best (dormakaba)	45H
	Marks (Marks USA)	195

Cylindrical Locksets:	Yale	5400 with PB stile lever
	handle Best	9K
	Marks	95 Series

2. KEYS AND KEYING:

- A. Provide keyed brass construction cores and keys during the construction period at all exterior and interior doors.
- B. Construction control and operating keys and core shall not be part of the Owner's permanent keying system or furnished in the same keyway (or key section) as the Owner's permanent keying system. Permanent cores and keys (prepared according to the accepted keying schedule) will be furnished to the Owner.

SECTION 08 00 00 - DOORS AND DOOR HARDWARE

- C. Cylinders, removable and interchangeable core system: Existing Best CORMAX™ Patented 7-pin.
- D. Permanent keys and cores: Stamped with the applicable key mark for identification. These visual key control marks or codes will not include the actual key cuts.
- E. The Owner, or the Owner's agent, will install permanent cores and return the construction cores to the Hardware Supplier. Construction cores and keys remain the property of the Hardware Supplier.
- F. Keying Schedule: Arrange for a keying meeting, and programming meeting with Architect, Owner, and hardware supplier, and other involved parties to ensure locksets and locking hardware, are functionally correct and keying and programming complies with project requirements. Furnish 3 typed copies of keying and programming schedule to Architect.
- G. Key Codes Updates: To be imported into the campus Keystone Key Control Software.
- H. Door closers (when required)
 - a. Exterior doors will be surface mounted Best HD8000, or STCHC QDC 100/200/300, or LCN 4040, or Yale 4400 series with adjustable opening force of 8 to 15 lbs.
 - b. Interior doors will be surface mounted Best HD8000, or STCHC QDC 100/200/300, or LCN 4041, or Yale 4400 series where adjustable opening force may be set to less than 5 lbs.
 - c. Floor closers will be Rixon Model 27 or Dormakaba BTS 80 Series, or, an equal to this specification.
 - d. Must have through bolts if mounted on the door.
- I. Panic Hardware
 - a. Apex 2000 Series by Precision
 - b. Von Duprin #33 or #99 series.
- J. Hinges should be McKinney, Stanley ball bearing or equivalent specification.
- K. Door Operators should be dormakaba ED Series Low Energy Swing Door Operators, or Besam SW100, or Besam 900 series with a security board or Norton 5900 series. Must provide door stop.
- L. Where automatic door operators are used, install a doorstop to keep stress off of the operator when someone is leaning on it. Additionally, locate door stop in such a manner that it is not a tripping hazard and does not interfere with the normal cycling of the door operator.
- M. Finish should be 26D unless otherwise approved by the Project Manager.

SECTION 08 00 00 - DOORS AND DOOR HARDWARE

N. Warranty	
1.Hinges	Life time of building
2.Locksets Cylindrical (Grade 1)	10 years
3.Locksets Mortise (Grade 1)	Limited Lifetime of building
4.Exit Devise	5 Years
5.Closers	Limited Lifetime of building
6.Other hardware	2 years

Part 3 - Execution

1. Designer shall submit door hardware schedule with the door schedule for review by the Project Manager before the end of Design Development.
2. After consultation with the client, the Designer will prepare a key schedule (sample key schedule is below) for all locksets in contract documents. The Designer will confirm with the Project Manager which locksets will be keyed by hardware supplier and which by Vanderbilt Key Shop.
 - a. The initial keying of departmental areas in new construction and major renovations will be managed by the Contractor.
 - b. The involvement of the Plant Operations Key Shop is limited to the activities of keying areas which are under Plant Operations control, including mechanical rooms, electrical rooms, elevator mechanical access, data rooms, and custodial areas. Where newly renovated areas need to be tied into existing master key systems, the Plant Operations Key Shop will provide the reference information required to the contracted locksmith.
 - c. The Plant Operations Key Shop will be responsible for the maintenance of keys, cores, doors, hardware, and access systems following project completion. The Contractor to provide manufacturers operating and maintenance manuals for the complete door hardware installation as required for Closeout to Plant Operations Key Shop.

END OF SECTION -

SECTION 08 74 00 - ACCESS CONTROL HARDWARE**Part 1 – General****1.01 Scope:**

Provide electric locking hardware requirements and specifications for access-controlled doors. provide complete wiring diagram and coordinate with electrical drawings.

The following is a list of devices acceptable for use in openings where electric locking hardware is required. The intention of this list is to provide alternate means of equipping electronically controlled openings without the use of Electric Latch Retraction (ELR) hardware. The use of ELR hardware devices must be approved in writing by Project Manager in writing.

Part 2 - Products**2.01 Single Door**

1. Furnish electric hinge provided with a minimum of 8 conductors (10 or 12 conductors are preferable).
2. Furnish electrified mortise lock with lever handles whenever possible, i.e. new construction or compatible existing door, (Yale 8800 series hardware). The lock should be equipped with request-to-exit and latch bolt monitor switches. If a door is being retrofitted for electric locking hardware and a mortise lock is not compatible, an electric cylinder lock (Yale 5400 series) may be used or an electric strike (i.e. HES 1006) may be cut into the frame to coordinate with the existing locking hardware.
3. Furnish door position indicator. Use of a ¾” magnet is preferred.
4. When panic hardware is required by building codes for egress, furnish a full mortise panic device with electronic trim or a coordinating electrified mortise lock. VonDuprin panic hardware with electric trim or mortise lock are preferred.

2.02 Pair of Doors

1. Furnish electric hinge provided with a minimum of 8 conductors (10 or 12 conductors are preferable).
2. Where panic hardware is required furnish a rim panic device in conjunction with an HES 9600 electric strike or electric strike with like function. Either is acceptable and has proven to be much more reliable than ELR applications. The VonDuprin panic hardware with electric trim is preferred. It can be used on one or both doors in the pair.
3. Furnish keyed removable mullion at the center of the door opening for all double doors.
4. Furnish door position indicators so that both doors are monitored for position status. Use of a ¾” magnet is preferred.

2.03 Electric Strikes

1. Electric strikes are prohibited at doors where a positive latch mechanism is required by building codes. This includes all doors serving exit stairwells from exit access corridors.

SECTION 08 74 00 - ACCESS CONTROL HARDWARE

2. Electric strikes are acceptable when used with automatic door operators. Electric strikes are also acceptable at pairs of doors with panic devices and at existing doors to be retrofitted with electronic locking hardware (see above). At all other locations, electric hinges and electric locksets fitted with lever handles are preferred.
3. Electric strikes used on campus can be referenced at the following websites:
 - a. HES 9600 – www.assaabloyesh.com
 - b. HES 1006 – www.assaabloyest.com

2.04 Door Contacts

All exterior doors shall be equipped with monitoring capabilities to comply with the secure doors initiative. Door contacts commonly used on campus.

- a. George Risk Industries, Inc.
- b. Interlogix, a unit of United Technologies Corporation
- c. Honeywell-Commercial Security

2.05 Electric Hinges

- a. A sample electronic hinge used on past projects is shown at end of section.
- b. Additional wiring diagrams are available from the Project Manager for each project.

Part 3 – Execution**3.01 Lockset Operation**

1. At building exterior doors, the lockset shall be fail secure, i.e. the lockset shall remain locked to the exterior when there is a loss of power to the card reader or electric locking hardware.
2. At interior doors providing access to stairwells, the lockset shall be fail-safe, i.e. the lockset shall allow passage from either side of the door when there is a loss of power to the card reader or electric locking hardware. At interior cross-corridor doors, the lockset shall be fail-safe.
3. At interior doors that serve offices, conference rooms, labs, storage rooms or classrooms that are not classified as Assembly Occupancy the lockset shall be fail-secure. The reason is that these rooms normally contain equipment or items that need to remain secure during a loss of power.

SECTION 08 74 00 - ACCESS CONTROL HARDWARE

Locks (Yale electric cylindrical and mortise types)



Card Access Swipe

END OF SECTION

SECTION 09 00 00 - FINISHES

Part 1 – General**Part 2 – Products****Part 3 – Execution****3.01 Gypsum Wallboard**

1. Use 5/8" minimum, unless specific job conditions require smaller thickness.
2. Designer may consider use of synthetic gypsum.
3. For interior partitions using light gauge framing use 25 gauge at 16" O.C. minimum; use 20 gauge minimum for framing adjacent to doorways, windows or cased openings.
4. For exterior partitions using light gauge framing use 20 gauge at 16" o.c. minimum.
5. Indicate location or frequency of expansion joints in gypsum wallboard on drawings per manufacturer's recommendations.
6. In all residence halls, use National Gypsum Hi-Impact XP Board or approved equal in all areas accessible by students.

3.02 Painting

1. Paint Specifications shall be based on Porter Paint or Sherwin Williams
2. Paint shall be low or no VOC, unless a different paint is approved by the Project Manager for specific purposes.
3. PRIOR to preparation of Bid Documents, the Designer shall submit a list of brand names to the Project Manager for approval.

3.03 Flooring

1. When carpet is specified, carpet tiles are preferred over broadloom.
2. Cut pile carpet is allowable only with special permission of the Project Manager.
3. Acrylic impregnated flooring as manufactured by Permagrain Products, Inc., or their equivalent, shall not be used.
4. Review fiber type of carpet with Project Manager.

3.04 Mechanical Room Floors

1. All Mechanical Room finished floors above occupied space shall be Dexotex, epoxy or approved equal to achieve a waterproof seal and extend sealant up curb face.
2. All Mechanical Room finished floors not over occupied space shall be sealed concrete.

SECTION 09 00 00 - FINISHES

3.05 Ceilings

1. If Acoustic Ceiling Tile (ACT) is used, 2' x 2' is preferred.
2. Designer shall coordinate the location of above-ceiling equipment. Above ceiling equipment shall be located above lay-in ceiling wherever possible. Any equipment located above gypsum board ceilings must be reviewed and approved by the Project Manager and be provided with access panels.

END OF SECTION -

SECTION 10 11 00 - VISUAL DISPLAY SURFACES**Part 1 – General****1.01 Scope:**

The purpose of this section is to provide an outline of products that have been used in the past successfully at the University. Individual departments will have particular likes and dislikes about visual display surfaces, the designer should coordinate with the Project Manager to determine the correct fit for each project.

Part 2 – Products**2.01 Chalkboards**

Specifications shall include provision for treating/prepping chalkboards according to manufacturer's requirements.

2.02 Marker Boards

1. Ghent
2. Claridge
3. Or approved equal
4. All marker boards shall be either porcelain steel with aluminum trim or glass.

2.03 Projection Screens

1. In the case of Front Projection arrangements, glass bead viewing surface should not be specified; fiberglass matt white is preferred.
2. Acceptable brands are Da-Lite, Draper, or an approved equal.
3. Automatic projection screens are preferred. Only use manually operated screens with specific authorization of Project Manager.
4. Consider tensioned projection screens in classrooms that seat more than 35 students. Verify need for tensioned screens with Project Manager.

Part 3 – Execution

END OF SECTION -

SECTION 10 21 13 - TOILET COMPARTMENTS

Part 1 – General

Part 2 – Products

2.01 Material

1. Solid plastic, phenolic, thru color
2. Stainless steel
3. Plastic laminate

Part 3 – Execution

3.01 Mounting

1. Floor mounted with wall bracing.
2. All mounting brackets and accessories shall be stainless steel.
3. Specify a minimum of three (3) wall mount brackets, fastened to wall blocking, per panel.

END OF SECTION -

SECTION 10 28 00 - TOILET ACCESSORIES**Part 1 – General****1.01 Scope:**

The construction documents should specify all necessary equipment for complete restrooms and janitor's closets.

Part 2 – Products**2.01 Restroom Accessories**

1. *Soap dispenser, ask PM about hardwiring these.
2. Mirror
3. Electric hand dryers preferred in lieu of *paper towel dispensers, ask PM about hardwiring these
4. Grab Bars
5. *Toilet paper holder
6. Sanitary napkin receptacle
7. Coat hook inside stall

*These items may be provided by owner. Verify building standards with Project Manager.

2.02 Janitor's Closet Accessories

1. Heavy duty shelf and brackets capable of holding paper and chemicals
2. Sink located on floor
3. FRP board behind sink on adjacent walls
4. Mop rack with hooks mounted above floor sink

Part 3 – Execution

1. All hands free devices shall be hard wired on a separate circuit with GFCI, not battery operated
2. Prefer to have separate trash receptacle (under counter) from paper towel dispenser
3. Avoid in wall recessed trash receptacles.

END OF SECTION -

SECTION 11 00 00 - EQUIPMENT PROCUREMENT AND COORDINATION**Part 1 – General****1.01 Scope:**

1. BEFORE preparation of Contract Documents, Designer will consult with Project Manager to determine whether Vanderbilt wishes to purchase equipment directly or to have such equipment provided by Construction Manager.
2. If Vanderbilt decides to purchase equipment directly, the Project Manager will use the Designer's Drawings and Specifications in conjunction with a Vanderbilt-issued Request for Proposal (RFP) to equipment contractor or vendor. See VU standard specification section 00 73 00.03, "Tax Savings Procedures". The RFP, issued by the University Purchasing Department, will contain instructions to bidders, liquidated damages clauses (if applicable), and general conditions. The Designer will participate in the review of bids. The Designer will be expected to advise the Project Manager regarding negotiations with the successful bidder(s). The Designer will not negotiate directly with bidders.

Part 2 – Products

- a. Designer is required to consult the SBS (Appendix A) for detailed information on sustainable product selection criteria found in SBS Appendix D, 'Sustainable Checklist for Products and Furniture.'
- b. During preparation of Contract Documents, Designer will consult with Project Manager to determine which proprietary equipment lines may be preferable in terms of:
 - a. Quality
 - b. Price
 - c. Service
 - d. Sustainability
 - e. Lead Time
 - f. Warranty
- c. Vanderbilt will be given an opportunity to review Designer's drawings and specifications before such documents are finalized by the Designer.
- d. If requested by the Project Manager, Designer will provide manufacturers' equipment literature to be reviewed by Vanderbilt before equipment is specified. Designer should anticipate adequate lead time to allow ample time for review and revision.
- e. Unless directed by the Project Manager, the Designer will incorporate the following equipment in the Contract Documents to be provided by the Contractor:
 - a. 11 40 00 Food Service Equipment
 - b. 11 53 00 Laboratory Equipment
 - c. 11 61 00 Theater and Stage Equipment
 - d. 11 82 00 Solid Waste Handling Equipment

Part 3 – Execution

3.01 All plumbing, mechanical and electrical rough-ins for equipment will be carefully coordinated by Designer with equipment drawings and specifications. Location and type of rough-ins will be field-verified by Designer prior to delivery by equipment contractor. Contract Documents will succinctly delineate lines of responsibility between equipment and trade contractors.

-END OF SECTION-

SECTION 11 01 20 - WINDOW WASHING EQUIPMENT

Part 1 - General

Part 2 – Products

2.01 Window Washing Systems

The Designer shall review exterior and interior window washing procedures with the Project Manager. Provide necessary tie off points as needed. Window washing systems which require access adjacent to or remote from the building are discouraged.

Part 3 – Execution

END OF SECTION-

SECTION 12 00 00 - FURNITURE

Part 1 – General

1.01 Scope:

1. Underlined portions of this section apply to all Designers. Interior Designers should review entire section.
2. Before preparation of Contract Documents, the Designer shall verify with the Project Manager which furnishings Vanderbilt wishes to purchase directly and which furnishings shall be provided by the Contractor. All furnishings provided by the Contractor shall be incorporated in the Designer's Contract Documents. Unless specifically directed otherwise by the Project Manager, the Designer shall incorporate the following furnishings in the Contract Documents, to be provided by Contractor:
3. Designers who are contracted by Vanderbilt to provide interior design services should expect that Vanderbilt will purchase fixed and moveable furniture directly. The Designer will prepare a layout plan which is coordinated through code or schedule with furniture specified. The Designer will prepare complete specifications for all furnishings. In developing a list of furnishings designers shall refer to the SBS, Appendix D, 'Sustainable Checklist for Products and Furniture' (Appendix A). Vanderbilt will use the Designer's Drawings and Specifications, in conjunction with an Owner-issued Request for Proposal (RFP) to furniture manufacturers or vendors. The RFP, issued by the Purchasing Department, will contain instructions to bidders, liquidated damages clause (if applicable), and general conditions. The Designer will participate in the review of bids. The Designer will be expected to advise the Project Manager regarding negotiations with the successful bidder(s). The Designer will not negotiate directly with bidders.

Part 2 – Products

1. Before preparing proprietary specifications, the Designer will consult with the Project Manager to determine whether Vanderbilt wishes to bid furniture among manufacturers, local suppliers or work with a selected vendor.
2. During preparation of Drawings and Specifications, Designer will consult with the Project Manager to determine which proprietary furnishings are preferable in terms of:
 - Quality
 - Price
 - Sustainability metrics per the SBS, Appendix D, 'Sustainable Furniture and Products Checklist' (Appendix A).
 - Service
 - Lead Time
3. If requested by the Project Manager, the Designer will provide manufacturers' literature to be reviewed by Vanderbilt. Vanderbilt will be given an opportunity to review Designer's drawings and specifications before such documents are finalized by the Designer. Designer should carefully consider probable necessary lead time to allow ample time for review and revision.
4. Custom-made furnishing shall be detailed and specified by the Designer in such a way that it can be competitively bid.
5. Where floor rises stepwise, i.e., when specifying auditorium, fixed classroom or stadium seating, the Designer shall specify riser mounted seating.

SECTION 12 00 00 - FURNITURE

Part 3 – Execution

1. The Designer will undertake all submittal and shop drawing review of custom-made furnishings and any other furnishings provided by the Contractor.
2. When fixed furnishings are specified, the Designer will inspect rough-in requirements and installation of fixed furnishings.
3. The Designer will inspect moveable furnishings upon delivery.
4. The Designer will provide Vanderbilt with written verification of field inspection of furnishings and compliance of furnishings with Drawings and Specifications. If defects or non-compliance are discovered, Designer will notify the Project Manager in writing of such defects or non-compliance. Written verification of inspection must be provided prior to completion of final punch list.

END OF SECTION -

SECTION 12 20 00 - WINDOW TREATMENTS**Part 1 - General****Part 2 – Products****2.01 Window Treatments**

1. The A/E will review all window treatments (shades or blinds) selections with the Project Manager.
2. Window operators for custom-made non-proprietary windows should be Blaine or approved equal.
3. Window blinds should be 1" aluminum Bali, Levelor, Hunter-Douglas or approved equal. The standard color used for buildings on campus is Levelor "Alabaster" #112. Additional colors include bronze and white. Designers wishing to use another color will secure authorization to do so from the Project Manager.
4. Motorized window shades should be Mecho, Lutron, Draper or approved equal.

Part 3 – Execution

END OF SECTION -

SECTION 14 20 00 - ELEVATORS**Part 1 – General****1.01 Scope**

Furnish and install passenger elevator(s) as required to meet Code requirements. All work shall be performed in accordance with the American National Standard Safety Code for Elevators, Dumbwaiters, Escalators and Moving Walks (ANSI A-17.1), the National Electric Code and applicable state and local codes.

1. General

An approved manufacturer regularly engaged in manufacturing elevator equipment of the type required for this project. The manufacturer or authorized agent of an elevator equipment manufacturer with not less than ten (10) years of satisfactory experience installing and servicing elevator equipment equal in character and performance to the project elevator. Any welding on the site must be performed by personnel who have successfully passed an American Welding Society authorized test and whose welding work has been judged by a natural person who is fully authorized to do so by the American Welding Society. The authorized person who evaluates the welding must sign the certificate signifying applicant has passed required tests. No substitutions will be permitted.

The Installation Contractor must submit catalogs and show evidence that all required parts are kept in inventory within fifteen (15) miles of the elevator installation. The Installation Contractor must certify that he/she has a Service Office with full time employees within fifty (50) miles of the project site.

The Elevator Contractor is responsible for the expenses of the Elevator Inspector to witness all testing of the equipment. A Copy of the testing report must be turned over to the Owner and to the Elevator Contract Administrator for the University. The cost of all elevator inspections and certificates are to be paid for by the Contractor. Follow-up inspections required due to 'owner' violations shall be paid by the Owner.

1.1. Elevator phone and service shall be in accordance with University Standards.

1.2. Warranty period and maintenance period to be twelve (12) months and coincide with General Contractor's warranty.

1.3. Elevators to comply with ANSI A17.1 and ADA/ADAG.

1.4. Comply with Tennessee Department of Labor laws that regulate elevators. Designer shall specify that the Contractor is to pay all fees and to coordinate the inspection of the elevator system with the State Elevator Inspector.

1.5. Elevator certifications shall be witnessed by the Campus Project Lead.

1.6. If there is an attic or penthouse level the elevator shall service this level.

1.7. Non-public spaces shall be accessible by card reader or key access only.

1.8. Elevator rooms shall be sprinkled and equipped with shunt trip devices located outside of the elevator equipment room.

1.9. To keep University elevator equipment in a peak operating environment, all new and renovated elevators shall have air conditioning and humidity controls in the control cabinets or equipment rooms. Shaft ways exposed to exterior environment (i.e. parking garages) shall be provided with humidity control to prevent water condensation on rails and operating mechanisms. The spaces shall maintain a temperature range between 68 to 84 degrees Fahrenheit year-round.

1.10. For passenger elevators, the elevator speed shall be no less than 150 FPM. For freight elevators, the speed is to be determined according to project needs.

1.11. Provide Automatic Fireman's Recall System

1.12. Provide directional lanterns in the cab jams, both sides of the entrance columns and provide a car position indicator in the hall at the main floor of egress, minimum 2" in height.

1.13. Elevator cab lighting shall be LED light fixtures.

SECTION 14 20 00 - ELEVATORS

1.14. Provide all special diagnostic equipment, meters or monitors manuals needed to trouble shoot or repair elevators to the University. Proprietary equipment, computer hardware and software, shall not be permitted. Provide all user and service codes for all diagnostic equipment with instructions during project closeout. Any and all diagnostics tools required to adequately maintain the equipment become the University's property.

1.15. Two service and repair manuals for all elevators must be submitted. Service manual must include all diagnostic information. An owner's manual must be provided to the University. One of the three sets of wiring diagrams must be laminated. All items must be turned over to the University Project Lead upon completion. After the one-year warranty period, all service records, manuals and diagnostic equipment must be turned over to the University and signed for by the University Project Lead.

1.16. Provide key locks for independent service, fire service inspection, and lighting & fan (four keys for each lock). Fixtures shall be provided by Innovation Industries, Adams or GAL Manufacturing. All other manufacturers must be expressly approved by the University Project Lead.

1.17. All elevators installed in a dormitory our residential building must be equipped with vandal resistant fixtures.

1.18. Access to elevator equipment rooms shall be restricted.

1.19. Provide three copies of the "Certificate of Operation" to the University Project Lead – one to be posted in the elevator cab, one for the University Project Lead, & one for the Maintenance and Operations.

1.20. All elevator controls shall be of a non-proprietary type. Specified types of controls shall be Elevator Control (Pixel), Motion Control Engineering (2000, 4000 or I-Box) and GAL Manufacturing (Galaxy). OEM Controls to be allowed on a limited and approved basis only. Approval must be in writing from the University prior to acceptance.

1.21. All elevator controls to be microprocessor logic type. Provide in the service manual a ladder diagram or other source code, relay wiring diagram, showing all relays, devices and switches. The drawing set shall include electrical schematic diagrams and input/output schedules.

1.22. Elevator control logic for electric traction elevators to be independent or component control logic. All elevator specs to be reviewed by the University or their elevator consultant.

1.23. Hydraulic elevators to be equipped with a sealed PVC cylinder sleeve. The hydraulic cylinder assembly must be electrically isolated from the elevator and protected against electrolysis.

1.24. Hydraulic Elevators are to be installed when travel is less than forty (40) feet in rise. MRL Hydraulic Elevators are not permitted to be installed unless express written permission is granted. Elevators not on Emergency Generator must be on a Battery Lowering System. All hydraulic elevators will be installed with an oil recovery system that automatically returns the fluid back to the main reservoir.

1.25. Elevator machine and control rooms shall not be located near classrooms or sound sensitive areas.

1.26. Hydraulic shut off valves are required at the machine room and pit areas. The oil line must be equipped with an effective muffler device that removes the hydraulic pump pulsations and noise before being transmitted to the hydraulic cylinder through the oil supply line.

1.27. Elevator Permits

1.27.1. Permit shall be paid for out of project that installs elevator.

1.27.2. Permits shall be applied for in advance of completion to avoid any unnecessary delays in the permitting process.

1.28. All elevator machine and control rooms shall be finished in accordance with "Interior Finishes."

1.29. No floor drains are permitted in any elevator mechanical room.

1.30. All elevator pits shall be sealed and watertight, with minor slope to the sump pit. Sump to be located in a rear wall corner. Sump pit must be a minimum of 2' x 2' x 2' with a galvanized steel grate cover.

1.31. Provide an oil cooler as needed.

1.32. Designer shall review the requirements of these and other design guidelines and confirm compliance with current code.

1.33. Elevators on EDG is available.

1.34. All elevators should be able to be recalled to the main floor, using emergency generator or

SECTION 14 20 00 - ELEVATORS

battery backup for the effort.

Part 2 – Products**2.01 Acceptable Manufacturer's**

1. ThyssenKrupp Corporation
2. Schindler Group
3. Kone
4. Approved equal

1.22. Elevator control logic for electric traction elevators to be independent or component control logic. All elevator specs to be reviewed by the University or their elevator consultant.

1.23. Hydraulic elevators to be equipped with a sealed PVC cylinder sleeve. The hydraulic cylinder assembly must be electrically isolated from the elevator and protected against electrolysis.

1.24. Hydraulic Elevators are to be installed when travel is less than forty (40) feet in rise. MRL Hydraulic Elevators are not permitted to be installed unless express written permission is granted. Elevators not on Emergency Generator must be on a Battery Lowering System. All hydraulic elevators will be installed with an oil recovery system that automatically returns the fluid back to the main reservoir.

1.25. Elevator machine and control rooms shall not be located near classrooms or sound sensitive areas.

1.26. Hydraulic shut off valves are required at the machine room and pit areas. The oil line must be equipped with an effective muffler device that removes the hydraulic pump pulsations and noise before being transmitted to the hydraulic cylinder through the oil supply line.

1.27. Elevator Permits

1.27.1. Permit shall be paid for out of project that installs elevator.

1.27.2. Permits shall be applied for in advance of completion to avoid any unnecessary delays in the permitting process.

1.28. All elevator machine and control rooms shall be finished in accordance with “Interior Finishes.”

1.29. No floor drains are permitted in any elevator mechanical room.

1.30. All elevator pits shall be sealed and watertight, with minor slope to the sump pit. Sump to be located in a rear wall corner. Sump pit must be a minimum of 2’x 2’ x 2’ with a galvanized steel grate cover.

1.31. Provide an oil cooler as needed.

1.32. Designer shall review the requirements of these and other design guidelines and confirm compliance with current code.

Part 3 - Execution**3.01 Temporary Service:**

Should the service of the elevator be required for use during the construction period by the contractor or subcontractors, authorization must be obtained in writing from the Project Manager. In no case shall the Warrantee period be reduced to the owner.

3.02 Maintenance Service:

The elevator contractor shall furnish maintenance and call-back service on the elevator(s) after it is completed and placed in operation for a period of twelve months following Owner's acceptance for beneficial occupancy.

SECTION 14 20 00 - ELEVATORS**3.03 Special Features:**

1. Emergency fire service and emergency lighting shall be accordance with ANSI 17-1. Elevator shall be installed in accordance with all appropriate Handicapped requirements.
2. Provisions shall be made to operate elevator by magnetic card insertion in all dormitories.
3. Contractor/Elevator manufacturer shall provide a computerized traffic analysis report to insure compliance with specifications and equipment performance and traffic handling capability. This report shall be included in the Operating and Maintenance manuals turned over to Vanderbilt at time of project completion.
4. Elevator Contractor shall be required to furnish telephone wiring from elevator cab to (1) elevator machine room or (2) telephone terminal board, whichever is closest. Telephone wire shall be solid twisted pair, 22 gage minimum. If wire is taken to elevator machine room, 1/2" conduit shall be provided from elevator machine room to closest telephone terminal board. Immediately prior to installation, elevator contractor shall notify VU Telecommunications to (1) review location of wiring terminus and (2) schedule installation of elevator cab handset.

END OF SECTION -

21 00 00 FIRE SUPPRESSION**A. GENERAL**

1. Do not specify dampers that use fusible links.
2. Test Connections
 - a. For each water flow indicator, specify an inspector's test connection that consists of a test pipe not less than 1 inch diameter that terminates in a smooth bore corrosion resistant orifice giving a flow equivalent to one sprinkler head of the type installed on the system.
 - 1) Specify the test connection discharging to the building exterior.
 - 2) Locate the control valve for the inspector's test connection not more than 7 feet above finished floor.
3. Equipment Type Acceptance
 - a. Specify the main control valves furnished with tamper-proof contacts for connection to the building fire alarm system.
4. For pipe material, see VU A&E GUIDELINES Div 22.
5. See alarm standards in Section 28 31 00 in VU A&E GUIDELINES Part 2.

B. DESIGN REQUIREMENTS

1. Specify that installation of automatic sprinkler systems for fire protection comply with the following current codes and standards.
 - a. State Building Code
 - b. Fire Marshal's Rules
 - c. NFPA 13, Standard for Installation of Sprinkler Systems.
 - d. Common motor requirements

C. FM GLOBAL REQUIREMENTS

1. Automatic sprinkler protection should be provided for all areas where either combustible construction or combustible occupancies are present. This includes such areas as above combustible suspended ceilings, under mezzanines, shelves, ducts or other raised obstructions over 4 ft. wide, inside small, enclosed offices, in combustible concealed floor or ceiling spaces, and in electrical closets where combustibles cannot be eliminated. Placement of sprinklers should be in accordance with FM Global Property Loss Prevention Data Sheet 2-0, *Installation Guidelines for Automatic Sprinklers*.
2. Design new automatic sprinkler systems in accordance with FM Global Property Loss Prevention Data Sheet 3-26, *Fire Protection for Nonstorage Occupancies*.
3. A full set of sprinkler drawings, hydraulic calculations and specifications (material data) should be submitted to the FM Global Atlanta Operations office for review and acceptance prior to beginning work.
4. A full set of fire pump drawings; detailed data describing the pump, driver, controller, power supply, fittings, suction and discharge connections; and water supply conditions should be submitted to the FM Global Atlanta Operations office for review and acceptance prior to installation.

5. Provide a 10% safety margin between the sprinkler demand and the water supply, where it does not stress the design of the project too greatly, in order to account for error in water supply tests, changes to water system (public), nearby water customers, etc.
6. Omission of sprinklers above the suspended ceiling and in any other area will be satisfactory only on the basis of the following:
 - a. Limited combustibles are in the concealed space and are not significant enough to maintain a self-propagating fire. (Foamed plastic insulation and other insulations with an ASTM E-84 flame-spread index [FSI] greater than 25 do not qualify).
 - b. All electrical wiring in the concealed space is installed in accordance with FM Global Property Loss Prevention Data Sheet 5-31, *Cables and Bus Bars*.
 - c. Insulation for metal air-conditioning ducts is FM Approved or non-foamed plastic with an ASTM E-84 flame spread index of 25 or less.
7. FM Global recommends using galvanized, stainless steel, or similar corrosion-resistant pipe in all new dry-pipe, preaction, refrigerated-area, deluge, and exposure protection sprinkler systems except where the ambient temperatures in the area of the system exceed 130°F. The periodic tripping and resetting of dry systems, required to ensure proper operation, can leave moisture in the piping. This moisture tends to corrode steel piping and greatly reduces the life span of the pipe as well as cause piping obstructions.
8. All materials used in new automatic sprinkler system installations should be FM Approved. FM Approved products are all marked with the FM APPROVAL mark. This includes, but is not limited to, sprinklers, sprinkler piping/fittings, pumps, pump controllers, fire alarm systems and smoke detectors. The *Approval Guide*, a publication of FM Approvals, may be referenced at www.approvalguide.com.
9. Install the automatic sprinkler systems per FM Global Property Loss Prevention Data Sheet 2-0, *Installation Guidelines for Automatic Sprinklers*. Final acceptance of the automatic sprinkler systems will be by field examination and satisfactory completion of the FM Global Form FM85A, *Contractor's Material and Test Certificate for Automatic Sprinkler Systems*.

END OF SECTION

21 13 00 SPRINKLER SYSTEMS**A. WET PIPE SYSTEMS**

1. Because the Owner tests fire suppression systems following NFPA requirements, design the system as follows.
 - a. To test the system residual pressure, adequately accommodate the full flow through the main drain of the system.
 - 1) A floor drain in the same room is not an acceptable solution.
 - 2) Pipe drains to a building sump or to outside the building.
 - b. Provide one inspector's test valve for each zone of the system, with outlets located to allow visual identification of flow and the control of flow for a prolonged period of time.
 - c. Design and specify the installation of the system to be completely drained, without water remaining trapped in the system.
2. Looped or double riser crossed connected systems are acceptable if flow alarm issues are successfully resolved.
3. Design one or more zones per floor, using major smoke/fire barriers as perimeters.
 - a. For each zone, specify the following.
 - 1) control valve with tamper switch
 - 2) flow switch
 - 3) test and drain valve
4. Specify gate valves with built-in tamper switch.
5. Specify combination three-way test and drain valves.
6. Do not specify plastic bodied flow sight glasses.
7. For sprinkler heads in the elevator machine room, top of the elevator shaft, and elevator pit, specify each head to have a shut-off valve with built-in tamper switch.
8. Specify semi-recessed type sprinkler heads with glass bulb.

B. DRY PIPE SYSTEMS

1. Instead of using the building control system as an air source, specify a separate compressor with manual controls.
2. Locate condensation "drum drips" to allow for regular draining without the use of a ladder.
3. Specify an air pressure monitoring device and alarm connected to the Owner's Building Automation System (BAS).
 - a. For information on the BAS, see VU A&E GUIDELINES Div 25 Part 2.

21 13 00 SPRINKLER SYSTEMS**C. PREACTION SYSTEMS**

1. Design as a stand-alone system with a local control panel and separate detection.
 - a. Do not rely on the building fire alarm system for operation.
 - b. Connect the control panel to the building fire alarm control panel as an annunciated zone, along with the trouble indication from the system.
2. Give special attention to the following.
 - a. The need to dry the system after it fills.
 - b. The placement of drains and condensate traps, which are usually over specialized areas.
3. Specify an air pressure monitoring device and alarm connected to the Owner's BAS.

D. DOUBLE INTERLOCKED PREACTION SYSTEMS

1. These systems utilize a detector system and pressurized air or gas in the sprinkler piping.
2. Design as a stand-alone system with a local control panel and separate detection.
 - a. Do not rely on the building fire alarm system for operation.
 - b. Connect the control panel to the building fire alarm control panel as an annunciated zone, along with the trouble indication from the system.
3. Give special attention to the following.
 - a. The need to dry the system after it fills.
 - b. The placement of drains and condensate traps, which are usually over specialized areas.
4. Specify an air pressure monitoring device and alarm connected to the Owner's BAS.

END OF SECTION

SECTION 22 05 00 - COMMON WORK RESULTS FOR PLUMBING**Part 1 General**

- 1.1 Normal plumbing piping systems such as waste, water, roof drainage, and footing drainage, etc. inside buildings to a point 5-foot outside the building are covered by this section; beyond that point, DIVISION 32, SITEWORK governs.
- 1.2 Many areas of the Campus have experienced building water supply pressures lower than desirable in which case domestic water booster pumping systems are required. The Designer shall declare the appropriate building water pressure needs to the Project Manager during Schematic Design.

Part 2 Products**Part 3 Execution**

- 3.1 Building basement drains and footing drains are at times required to be installed below the inverts of existing gravity sewers. Where this condition occurs, appropriate sump pumps are required. These pumps shall be located outside the building envelope such that mechanical or electrical failure will not cause direct flooding of the building.
- 3.2 Since Metro Water & Sewer no longer approves combination sewers, which contain both sanitary waste and storm drainage, building systems are to be separated.
- 3.3 All mechanical rooms shall have a floor drain with floor sloped to drain. All equipment requiring drains shall have conveniently located drains.
- 3.4 All floor drains installed below the invert of site gravity drain piping shall have backwater valves.
- 3.5 Sump pumps shall be of the duplex type and have mechanical/electrical failure alarms of the audible or visible type. Where buildings have data gathering panels, the alarm shall be supervised at the VU Power Plant. Contact Building System Control (BSC) Supervisor at 322- 2715 with questions. All inlet piping to sump pumps shall have an isolation valve located in a clearly identified and accessible place.
- 3.6 Backflow preventers shall be installed inside buildings. Always install pressure reducing valves upstream of the reduced pressure backflow preventers.
- 3.7 Must have valve tag list/chart that shows number, location, service and normal position.
- 3.8 All water hammer arrestors must be reasonably accessible.
- 3.9 Domestic water systems shall have Cold Water, Hot Water and Hot Water Return shutoff on each floor. Review location with Project Manager, typically Vanderbilt wants these shut offs to be near the restroom or closet served.
- 3.10 Domestic water systems shall have a shutoff valve serving all external hose bibs and external fixtures.

SECTION 22 05 00 - COMMON WORK RESULTS FOR PLUMBING

- 3.11 Plumbing piping systems shall not be located in areas subject to freezing such as outside walls or unheated spaces. Where required to be subject to freezing potential, approval must be obtained from the Project Manager; then, only with insulation and electric heat tracing supervised for failure conditions.
- 3.12 Horizontal portions of roof leaders inside buildings shall be insulated to prevent condensation.
- 3.13 Domestic water systems shall have Cold Water, Hot Water and Hot Water Return shutoff on each floor. Review location with Project Manager, typically Vanderbilt wants these shut offs to be near the restroom or closet served.
- 3.14 Domestic water systems shall have a shutoff valve serving all external hose bibs and external fixtures.
- 3.15 Plumbing piping systems shall not be located in areas subject to freezing such as outside walls or unheated spaces. Where required to be subject to freezing potential, approval must be obtained from the Project Manager; then, only with insulation and electric heat tracing supervised for failure conditions.
- 3.16 Horizontal portions of roof leaders inside buildings shall be insulated to prevent condensation.
- 3.17 Gas or oil fired boilers > 0.4 MMBTU in size should be FM Approved and utilize FM Approved devices such as fuel safety shutoff valves (SSOVs), fuel and air supervisory switches, timers, and flame failure supervisory combustion safeguards, etc. See FM Global Property Loss Prevention Data Sheet 6-4, *Oil- and Gas-Fired Single-Burner Boilers*, Table 1, for a summary of safety control recommendations. Please submit specifications regarding the equipment to be used, including a detailed list of all safety device manufacturers and trade names/part numbers, as well as a diagram of the fuel train piping arrangement to FM Global for review and acceptance prior to installation.
- 3.18 Gas or oil fired boilers ≤ 0.4 MMBTU in size should conform to American Gas Association standards.
- 3.19 Provide FM Approved or noncombustible cooling towers. Where combustible cooling tower components are present, provide automatic sprinkler protection.

END OF SECTION-

SECTION 22 06 00 - PLUMBING PIPING**Part 1 General**

- 1.1 Cast-iron soil pipe shall meet Cast-Iron Soil Pipe Institute (CISPI) standards.
- 1.2 Galvanized piping 4-inches and larger for domestic water applications is unacceptable.

Part 2 Products**Part 3 Execution****3.1 Domestic water piping**

Domestic water piping used above grade, inside buildings, shall be type "L" copper regardless of size. It is acceptable to use type 316 stainless steel piping for pipe sizes 3" and larger.

Piping used below grade, 2-1/2-inch nominal pipe size and smaller shall be type "K" copper; above 2-1/2-inch below grade, use cement-lined ductile iron.

In specific cases, PVC may be acceptable as an approved alternate only.

Above Ground Valves:

For 2" and smaller use bronze ball valve rated for bubble tight shutoff at 600 psid, with chrome plated ball, threaded connections and Teflon seats.

For 2-1/2" and larger use class 125 flanged end, epoxy coated cast iron gate or ball valve, rated for bubble tight shutoff that meets ANSI class VI allowable leak rate.

Install all valves so the valve handle points in the direction of flow when open, and in horizontal runs the valve handle shall point straight down when closed.

Locate valves in accessible locations, and in corridors if possible.

3.2 Sanitary and roof drainage piping

Sanitary and roof drainage piping shall be cast iron no-hub above grade; below grade use cast-iron push-on bell and spigot joints.

3.3 Perforated polyvinyl chloride (PVC) piping

PVC piping is to be used for footing drainage.

3.4 Acid Waste Piping & Equipment

Acid waste piping and vent fittings shall be:

- Polypropylene (P.P.) with 'Fuse Seal' or mechanical coupling joints.
- Kimax glass with mechanical coupling joints.
Install waste and vent piping at a minimum 1/4" per foot slope.

SECTION 22 06 00 - PLUMBING PIPING

3.5 Deionized/Distilled Water Piping

Deionized/distilled water piping and fittings shall be polypropylene pipe with fusion weld socket- type fittings.

END OF SECTION –

SECTION 22 07 00 PLUMBING INSULATION**Part 1 General**

Where the temperature difference between the environment and the surfaces of piping and equipment are conducive to energy loss or condensation, thermal insulation is required. Where condensation is possible, provide a vapor barrier.

Part 2 Products**2.1 Removable Jacketing**

Removable jacketing for valves shall utilize the following components as manufactured by Auburn Manufacturing, Inc. or equivalent:

1. Inner lining: AMI GL2025-XX-9383 heat treated fiberglass cloth (<450F).
2. Insulating material: AMI AM1000 needled fiberglass mat (<1000F).
3. Outer cover: AMI AGL2025 aluminum foil laminated fiberglass cloth.
4. Fastener: AMI GLR188HD fiberglass, draw string.

2.2 Rigid Fiberglass

1. Rigid fiberglass with an all-service-jacket (ASJ) is preferred for all piping applications.
2. The use of flexible elastomeric insulation is limited to refrigerant piping and cold surface applications provided it meets NFPA 90 smoke developed/flame spread rating of 25/50 only if approved by the Project Manager on a case-by-case basis.

2.3 Vapor Barriers

1. Vapor barriers may be of aluminum foil or mastic.

2.4 Pipe Fitting Insulation

1. Pipe fitting insulation shall have covers equivalent to those manufactured by Zeston.
2. On 2" and larger piping insulated with fiberglass insulation, a foamglass saddle equal in thickness to the insulation shall be installed. The saddle shall be 18" long and shall cover 180° of the pipe. A 16-gauge sheet metal shield shall be placed between the hanger and saddle.
3. Where metal jacketing is required, install jacket with seam on the bottom of the piping. Secure jacketing with ¾" wide stainless steel bands on 18" centers.

2.5 Piping Insulation

1. Insulation for pipe, valves, and fittings shall be per code with the following minimums:
2. Pre-molded, rigid fiberglass insulation will be used on the following services:
 - a. Domestic hot water supply and re-circulating – 1" thick.
 - b. Domestic cold water piping – ½" thick.
 - c. Horizontal rainwater leaders and roof drain bodies – 1" thick.

SECTION 22 07 00 - PLUMBING INSULATION

3. Where new insulation is installed on existing piping systems, the new insulation thickness may match adjacent piping insulation thickness with prior approval by the Owner.
4. Provide steel pipe covering protection saddle insulation shields on piping when roller hangers are utilized. The thickness of the insulation shields shall be equivalent to the insulation thickness.

Part 3 Execution

1. Pipe that is insulated outdoors, inside tunnels, or subject to abuse shall have smooth-aluminum-jacketing, .016 inches thick minimum.
2. Use rigid insulation for equipment.
3. Where service access is required for valves or other equipment underneath insulation, provide a means for temporary removal of the insulation without its destruction. Use prefabricated removable jacket for valve insulation on steam isolation, by-pass, and pressure reducing valves and condensate valves larger than 2-1/2 inch.
4. Do not insulate pump casings, valve stems, or hydronic expansion tanks.
5. Extend piping insulation without interruption through walls and floors. Install protective sheet metal insulation shields at hanger locations for all piping.
6. Insulate all piping and equipment subject to producing condensation and as required to maintain thermal properties.
7. Install insulation to allow clearances and access for servicing and maintenance to all equipment.
8. Nameplates or other tags, which provide equipment data, shall not be covered by insulation.

END OF SECTION -

SECTION 22 30 00 - PLUMBING EQUIPMENT**Part 1 General****1.01 Scope**

Facilities which require heaters for domestic water shall be installed to utilize steam from the Campus Central Steam Distribution System where available. Where facilities are not served by this system, the Designer shall evaluate the life cycle cost for using public energy sources versus extension of the central steam system to the building. The results shall be presented to the Project Manager during the schematic phase of design but no later than the project budgeting stage.

Part 2 Products

- 21 Steam-fired water heaters shall have electronic control valves and electronic controls, connected to the Building Management System and be rated for 150 psig steam.
- 22 Domestic water heaters of the NATURAL GAS storage type shall be constructed of steel with glass liner. Heaters are to be condensing, AGA approved, and meet code requirements for efficiency and stand-by heat losses.
- 23 Where Electric storage type water heaters prove effective, heaters shall be UL listed and have non-simultaneous operating thermal elements.

Part 3 Execution

3.01 A floor drain shall be installed for each water heater; water heaters installed outside dedicated mechanical spaces shall be set in a 4-inch deep drain pan with piped drain to an appropriate drainage receptor. Pressure relief valve discharges are to be piped to a drain receiver with an air gap. Gas heaters shall be ventilated in accordance with NFPA-56. Steam heaters shall have inlet pressure gauges, pressure reducing (PRV) stations, and manual bypass around the PRV station.

END OF SECTION -

SECTION 22 42 00 - PLUMBING FIXTURES

Part 1 General

In an effort to preserve resources, plumbing fixtures shall be of the water-saving type with flow restrictors where appropriate. At the direction of the Owner, water-less urinals may be required.

Part 2 Products

- 2.1 Lavatories shall have washer-less faucets with ceramic seats.
 - Public lavatories are to have single-lever faucets and strainer drain fittings.
 - Private lavatories shall be pop-up drain fittings. Where lay-in lavatories are required, the self-rimming type must be used.
 - Automatic flush valves and faucets shall be hard wired.
- 2.2 Washout-type water closets and urinals are preferred; the blow-out types are never to be used in back-to-back gang arrangements. Public water closet seats shall have open fronts, no top, and check-stop hinges.
- 2.3 Shower fittings shall be of the institutional type with single-lever temperature regulated faucets and fixed adjustable spray nozzles.
- 2.4 Floor drains shall be constructed of cast-iron. Strainer tops in finished pedestrian traffic areas shall be bronze or nickel; those exposed to vehicular traffic or in mechanical rooms shall be cast-iron. Drains which receive piped effluent from mechanical systems shall have 8" square, recessed tops.
- 2.5 Drinking fountain selection shall include a water bottle filler option for new fountains or a conversion kit for existing fountains similar to the Elkay EZ H2 Bottle Filling Station.

Part 3 Execution

- 3.1 All roof drains shall have under-deck clamps. Drains installed in lightweight roofs constructed with metal deck and above-deck insulation shall have sump receivers.
- 3.2 All plumbing fixtures shall be installed with stop valves, integral or separate, for isolation during normal maintenance.
- 3.3 Plumbing fixtures which are wall hung shall be installed with manufactured wall carriers.
- 3.4 Where floor or roof drains are installed, the floor or deck is to be sloped towards the drain; flat roofs and floor slabs with drains are unacceptable.
- 3.5 The location of shower nozzle discharge shall always be at right angles to the shower entrance unless the shower stall is unusually large.
- 3.6 Valves shall be per Section 23 05 23.

END OF SECTION -

SECTION 23 05 00 - BASIC MATERIALS AND METHODS**Part 1 General****1.1 Utility Layout and Distribution**

The Designer shall receive approval of Project Manager early in the design process as to routing of all utilities. All efforts should be made to avoid routing any utility in such a way as to require trenching or any disturbance in the root zone of campus trees. Consolidate and restrict utilities to every extent possible to those grounds areas having already received utility runs.

1.2 Utility Tunnel Penetrations

The tunnel penetrations shall be watertight. Fire boundaries shall be addressed. The tunnel penetrations shall be designed for expansion and contraction to maintain a watertight seal.

Any proposed use of utility tunnels must be reviewed with and approved through Project Manager. Penetration of any utility tunnel must be core drilled.

1.3 Campus Utility Base maps

Some drawings showing the location of existing lines for these networks may be found at the Office of Facility Information Services (OFIS), 322-2715, Room 106A, Bryan Building. Arrange in advance through the Project Manager to review what coverage is available or schedule directly through the Center. Costs of printing arranged through Campus Planning will be chargeable.

Part 2 Products**2.1 Cleaning**

Thoroughly clean ducts and apparatus casings before fans and filters are operated.

The following cleaning sequence shall be inserted in all contract document specifications verbatim:

2.2 HVAC Closed and Open Water Systems

1. The Contractor is to review specific cleaning plans with Vanderbilt University's preferred vendor, Nashville Chemical
 2. Initial flushing:
 - a. Remove loose dirt, mill scale, metal chips, weld beads, rust, and like deleterious substances without damage to any system components.
 - b. Bypass factory equipment unless acceptable means of protection are provided, or by subsequent inspection of water boxes and other "hide-out" areas take place.
 - c. Isolate or protect "clean" system components including pumps and pressure vessels and any component that may be damaged.
 - d. Open all valves, drains, vents, strainers, and the like at all system levels. Close all valves isolating piping from the existing central piping systems.
-

SECTION 23 05 00 - BASIC MATERIALS AND METHODS

- e. Sectionalized system to obtain debris carrying velocity of six feet per second using valves.
 - f. Connect dead end supply and return headers and the like as necessary, or provide drains in dead end eccentric caps.
 - g. Install temporary strainers where necessary to protect downstream equipment.
 - h. Supply and drain-off "flushing" water by fire hoses, garden hoses, temporary or permanent piping, Contractor's booster pumps, and the like.
 - i. Flush for not less than four hours. Drain all dirt legs. If water drained is not visibly clean, repeat the above procedure until dirt legs are visibly clean.
3. Cleaning (Closed Systems Only):
- a. Protect existing work, and specifically adjacent electrical equipment from damage.
 - b. Install temporary strainers, reinforced against blowout, sized to not impair equipment performance, to preclude passing of particles larger than 60% of smallest radial and at a minimum to retain all particles larger than 1000 microns.
 - c. Permanent facility pumps shall not be used for circulating cleaning water. Contractor shall supply temporary pumps for this process.
 - I. If the system construction, flow rates, and pressures are such that it is impractical for the Contractor to provide temporary pumps, the permanent facility pumps may be used with the specific express permission of the Owner, provided the guarantee on the entire pump assembly is unconditionally extended for two years after date of Substantial Completion. Leakage from pump seals or other damage resulting from circulating the uncleaned water shall require immediate rectification at no additional cost to the Owner.
 - d. Add 20 pounds of Garratt Callahan Formula 248, or equal, alkaline cleaner for each 1000 gallons of system water for chemical cleaning (approximate .2% solution). Formula 248 is a dry blend of buffered phosphates, a corrosion inhibitor, a surfactant, and an iron oxide sequestrant.
 - f. Circulate for a period of at least 72 hours. Monitor solution heat gain from pumping friction.
 - g. Every eight hours, blow-down the condensers and system low points for three minutes.
 - h. Drain and flush the system. Rapid flushing from the lowest point in the system is needed to remove debris.
 - i. Inspect the system and repeat first four steps.
 - j. Begin the corrosion control program immediately at double the normal inhibitor dosage for one week. After one week, drop to the normal dosage.
 - k. Chemical treatment compound: Use Garratt Callahan Company Formula 12-L closed system inhibitor strictly following manufacturer's directions.
-

SECTION 23 05 00 - BASIC MATERIALS AND METHODS

4. Domestic Water System:
 - a. Flush system progressively by opening building operable valves, faucets and hose bibs and permitting flow to continue from each unit until water runs clear.
 - b. Sterilize system in accordance with requirements of State Department of Public Health by the following method or other methods acceptable to authority having jurisdiction.
 - c. Introduce chlorine or a solution of calcium or sodium hypochlorite. Fill lines slowly and apply sterilizing agent at a rate of 50 ppm of chlorine as determined by residual chlorine tests at ends of lines. Open and close all valves while system is being chlorinated.
 - d. After sterilizing agent has been applied and left standing for 24 hours, test for residual chlorine at ends of lines. If test indicates there is less than 25 ppm, repeat sterilizing process.
 - e. After system has been standing 24 hours and test indicates at least 25 ppm of residual chlorine, flush out system until all traces of chemical used are removed.
 - f. Have local health department check and approve system before connecting it to existing water system.

5. Steam System:
 - a. Cleaning of steam piping consists of discharging steam at specified conditions and durations; flushing or circulation of cleaning/degreasing solutions are not required. The cleaning of steam piping shall occur prior to connection of all steam-fired equipment, pressure reducing stations and control valves.
 - b. Prior to placing any steam distribution in service to the building, the steam piping must be cleaned; either in its entirety or in segments. Segmented piping systems may result from the piping arrangement, future services, or to suit construction schedules.
 - c. Install temporary piping, valves, muffler, pressure gauge, and structural support as necessary to accommodate the discharge of steam in a manner to provide safety and noise mitigation for the surrounding environment. The point of discharge must be approved by the Vanderbilt project manager prior to installation.
 - d. Safety issues include:
 1. Structural provisions to restrain the temporary assembly from thrust created by the discharge and from thermal expansion.
 2. Insulation to protect individuals from heated surfaces.
 3. Mufflers designed to dampen noise to allowable OSHA sound levels. Provide hearing protection for operators, witnesses, and other personnel.
 4. Barricades, signage delineating a hazard zone within the discharge area to keep individuals at a safe distance during the cleaning process.
 5. Issue a request for the cleaning procedure from the Vanderbilt project manager at a minimum of 10 working days prior to the date and time of the proposed steam blows.

SECTION 23 05 00 - BASIC MATERIALS AND METHODS

6. Once approved, the cleaning procedure will be supervised by the VU Power Plant. Vanderbilt personnel will operate valves that admit steam to warm the new steam piping to the temporary valve at the point of discharge. During the warming process, condensate must be drained in the new piping until the pressure gauge at the temporary valve equals the steam pressure of the steam source.
7. With the new steam piping at a stable operating temperature and pressure, inspect the new steam line for proper thermal expansion and condensate removal.
8. At the direction of the VU Power Plant supervisor, slowly open the temporary discharge valve to the fully open position. The valve shall remain open until the appearance of the discharge steam is free of discoloration and debris
9. Slowly close the discharge valve. The VU supervisor will close the steam source valve and allow the new piping system to cool to the initial startup temperature. To aid in this process and the reheating open all drains for condensate removal after the steam source valve is locked out.
10. Repeat the warm-up cycle returning new steam pipe system to operating temperature and pressure. Again open the discharge valve slowly and observe the discharge of cleanliness.
11. Close the discharge valve once again leaving the new steam line at operating temperature and pressure. The VU supervisor will close the steam source valve and allow the new piping system to cool for a 24-hour period. Repeat blows in this fashion until the VU Power Plant supervisor is satisfied with the cleanliness of the system.
12. Once cleaned the new steam piping segment may be left in service or taken out of service. If the system remains pressurized, the VU Power Plant supervisor will install the necessary locks on isolation valves for safety. If the new piping system is removed from service, the VU Power Plant supervisor will restore locks on the steam source valve. Once placed in service, the contractor will re-torque all flange bolts to the required specifications.

e. Steam Condensate System

1. Cleaning of steam condensate piping requires flushing without circulation. Cleaning and degreasing agents are not required. Prior to returning condensate to the VU Power Plant, all condensate will be wasted to drain for a period of time determined by the VU Power Plant supervisor. The time period is predicated on the quality of condensate as determined by chemical analysis. That analysis will be provided by the VU Power Plant supervisor.
2. After the VU Power Plant supervisor approves the steam condensate cleanliness at each building, the condensate may be discharged to the building condensate return units and returned to the condensate return unit at the Power House.
3. Once placed in service, the contractor will re-torque all flange bolts to the required specifications.

2.3 Chemical Treatment

1. No chemical treatment system for chilled water is necessary when the facility is connected to the campus central chilled water system. All stand-alone systems shall utilize standard chemical feed systems and equipment specified in the contract documents. The contractor shall provide cleansing agents and all permanent chemical treatment supplies in standalone closed piping systems specified by the Owner's water treatment vendor. Circulating water systems both open and closed shall be chemically cleaned and treated by the contractor.
2. The engineer shall specify chemical composition, concentration, flow velocity and duration of circulation. All shall be in accordance with Vanderbilt's chemical treatment vendor instructions.

SECTION 23 05 00 - BASIC MATERIALS AND METHODS**2.4 Motors**

1. Poly-phase motors furnished as part of mechanical equipment shall be premium efficient motors with an efficiency service factor of 1.15 (minimum) and class F insulation. 480V, 60Hz type motors must have nominal full load efficiencies that meet the levels defined in NEMA MG-1 (2006) [Table 12-12]. The designer shall include salient components of Table 12-12 in the project manual.
2. Motors served by variable frequency drives [VFD] shall be ‘inverter duty rated’ and have insulated bearing or motor shaft brushes to eliminate the so-called “electrical discharge machining’ bearing failure derived from motor shaft bearing currents. The bearings or brushes shall be attached to an earth ground.
3. Motor and VFD Selection – the project engineer will make HP selections for all motor loads. Motors selected to operate on VFD’s may be allowed to operate at speeds above 60 hz, up to the maximum of 90% of motor name plate amperage. Test and Balance reports and Commissioning reports must note each occurrence of design capacity testing requiring motor operation greater than 60 hz along with the measured motor amperage an name plate amperage.

2.5 Variable Frequency Drives

Acceptable drive manufactures - these drive manufactures are approved when providing drives that meet the following criteria:

- ABB
- Square D
- Yaskawa

Variable Frequency Drives – all standard drive applications requirements apply to both integrated and independent units.

1. Drives provided will include:
 - Full electronic bypass
 - 3 year parts and labor warranty - from the date of startup
 - 5% line reactors

Operational applications that require a “hard wired – 3 contactor bypass” will be specifically identified in the design documents or by the Vanderbilt Project Manager.

2. Each drive is required to provide a Bacnet MS/TP connection to the building automation system. Bacnet BAS network visible points from each drive must include:
 - % Speed (rpm)
 - Power (kW) – Instantaneous power - enabled for 5 minute interval trending
 - Frequency (hz)
 - Command Speed

SECTION 23 05 00 - BASIC MATERIALS AND METHODS

3. Each drive shall be rated for continuous duty at 50 degrees centigrade. De-rating is permissible but must be identified in the required **VFD Submittal Table**.

Component ID	Motor HP	Drive Rated HP	Model #
<i>AHU-1 Supply Fan</i>	<i>40</i>	<i>50</i>	<i>xxxxx-xxx-xxxxx</i>

Part 3 Execution

3.1 Equipment and Systems Testing

No testing required by Division 15 of the project specifications shall occur without providing a minimum of 1-week notice to the Campus Planning mechanical engineer and/or construction coordinator. This requirement includes but is not limited to duct pressure tests, piping pressure tests, smoke evacuation system testing, fire pump testing, test & balancing of mechanical systems, required medical gas tests, etc. Any testing performed without providing the required notice may result in the contractor being required to retest the equipment and/or system at his own expense.

3.2 Inspections

When appropriate the contractor shall schedule and attend inspections by Campus Planning and Plant Operations prior to owner acceptance and completion of construction. These inspections include underground utilities, in-wall inspections, above ceiling inspections and final inspections.

END OF SECTION-

SECTION 23 05 13 - GENERAL PROVISIONS

Part 1 General

1.1 Scope

1. This document shall serve as minimum requirements for design and construction of mechanical systems for all buildings, both new and existing, at Vanderbilt University Campus. These documents are not intended to be used a reference in contract specifications nor shall they be inserted into contract specifications with the exception of certain requirements. Those paragraphs that are to be included are shown in *ITALICS* herein. Any design or construction not meeting or exceeding these minimum standards requires specific approval from the Office of Campus Planning and Construction.
2. Mechanical work includes plumbing, sprinkler, controls, insulation, heating, ventilating, air conditioning, and underground utility systems.
3. The design and installation of mechanical systems shall comply with state and local health departments, environmental protection agency, and building codes, including plumbing codes, and with state and local ordinances.
4. Ductwork construction, installation and ventilation systems shall comply with NFPA Standard 90A and SMACNA.
5. Equipment shall be U.L. listed and labeled as required in specific equipment chapters. Installation of systems shall comply with U.L. standards, where applicable.
6. The completed project shall pass any and all tests required by the authorities having jurisdiction.
7. Mechanical equipment shall comply with regulatory noise and safety standards for both indoor and outdoor spacesnc35 in classrooms, 55 dBa outdoors.
8. Mechanical systems and equipment shall be guaranteed against faulty material or workmanship for a period of not less than one year from the date of substantial completion or acceptance by the owner and/or the project commissioning agent or beneficial use, whichever date is the latest.
9. Counter-flash ducts, pipes and conduits where penetration of roofs or outside walls occurs; coordinate with Section 07 60 00.
10. All mechanical spaces shall maintain a minimum of at least 7 feet of clearance from floor to lowest obstruction for personnel passage.
11. Mechanical room floors located on the lowest floor lever should be provided with a standard floor sealer, rather than a painted surface. Mechanical room floors located above occupied spaces should be finished with a Dex-O-Tex or equivalent waterproof flooring. This includes floor areas under mechanical equipment. The floor under mechanical equipment shall be coated prior to equipment placement. The remainder of the equipment room floor shall be coated after all equipment is set in place.
12. Ductwork and piping located outside shall be provided with a means of weather-proofing approved by the Project Manager.

SECTION 23 05 13 - GENERAL PROVISIONS

13. Outdoor design temperatures are 0° degrees F. in the winter, 95/78° degrees F., dry-bulb and wet-bulb respectively. Indoor heating and cooling design temperatures are 72F dry bulb and maximum 53F dew point absolute humidity
14. When possible, mechanical equipment shall be labeled with design data (i.e. GPM, CFM, HP, heat transfer, etc.)

1.2 Drawings

Mechanical specifications shall require the mechanical contractor to generate composite mechanical plans coordinating all mechanical systems with structural, electrical, and communication systems. Coordination drawings shall show mechanical items to proper graphic scale. A general specification statement should be made that refers packaged equipment vendors to be applicable specification section to properly delineate materials of construction, i.e., fan coil suppliers shall be required to adhere to pipe, valve and control valve, specifications, etc. The A/E shall include project coordination drawings in their 'record drawing' closeout documentation. The coordination drawing format shall comply with the "Record Set Deliverable Requirements" published by the Vanderbilt Campus Planning Office of Facilities Information Services (OFIS) References on the coordination drawings shall be compatible and consistent with the contract drawings.

1.3 Maintenance Manuals

The maintenance information of each product or system should be preceded by the name, address, telephone number and e-mail address of the installer or subcontractor and a local source for parts and replacement equipment. The following information shall be provided where applicable for all products or equipment:

- Equipment and/or products shall be identified by names and/or symbols as set forth in the contract documents.
- Provide specification information consisting of drawings and a written description.
- Description of the function of equipment, pre-start-up procedures, functional parameters (input, output) at the design load and at part loads, and performance verification procedures.
- Recommended maintenance procedures and their recommended frequency.
- Provide performance curves, engineering data and tests.
- Provide a complete list of parts along with illustrations, part numbers, assembly drawings and diagrams required for maintenance.
- Original purchase order number, date of purchase, and warranty information.
- Installation information
- Predicted life of parts subject to wear.
- Lists of items recommended to be stocked as spare parts.
- List of lubricants required.
- Copies of approved submittal data.
- Data sheets shall be marked to identify the only those items germane to a given project.

1.4 Demolition

1. Prior to the use of cutting torches for removal of piping or equipment, obtain a 'burn permit' from the VU Project manager.

SECTION 23 05 13 - GENERAL PROVISIONS

2. Remove abandoned ductwork, duct straps, hangers, and supports, either associated with new work or previously abandoned.
3. Remove abandoned piping, hangers and supports. Provide shut-off valves and cap piping as near to the mains as possible.
4. All existing or new holes in slabs and fire or smoke rated walls will be patched with a fire/water proof sealant, to match the existing structure.
5. Prior to demolition of any ductwork, the T&B contractor shall take all readings required to identify existing airflow deficiencies to the VU Project Manager. These shall include readings at individual diffusers, registers or grilles, traverse readings at main supply, return or exhaust ducts, and fan, air handling unit or pump readings as described above. The design engineer should identify specific pre-demolition reading locations on the demolition/existing to remain drawings and/or in the project specifications.
6. Should any asbestos be identified within the renovation area, the architect, engineer and owner should be notified before continuing work.
7. Controls demolition includes:
 - a. Preparation and submission of a demolition plan to remove abandoned building automation system (BAS) field devices and control panels. Where sensors or controllers are removed from ductwork, abandoned penetrations are to be sealed with Hardcast duct-seal, RTA-50.
 - b. Remove pneumatic tubing back to the distribution header; cut and cap the tubing at the nearest main; remove all poly tubing back to the copper header.
 - c. Control panels, existing or new, shall not be used as a 'pull box'. No wiring or tubing must pass through BAS panels.

1.5 Commissioning

1. All projects shall be commissioned. At the discretion of the VU Project Manager the commissioning exercise may be accomplished by Vanderbilt Plant Operations or outsourced to a commissioning agent independent of the University. In either case, the Project Manual must include the commissioning scope of work to determine the impact of the commissioning process on work of this and other divisions.
2. The A/E shall include a commissioning section within the contract specifications created from the commissioning scope outline in Section 01 90 00 for projects having independent commissioning agents. For projects without an independent commissioning agent, the A/E shall include the following acceptance checklist to be performed by Plant Operations in Section 01 90 00 verbatim.

1.6 Mechanical

Specifications shall require the contractor to comply with the following:

1. Visually inspect all steam, chilled water, hot water or refrigerant piping, piping insulation, and pipe hangers.

SECTION 23 05 13 - GENERAL PROVISIONS

2. Verify that piping configurations, heat exchangers, and coils piped in the counter-flow configurations, drains, traps, and valves are accessible, serviceable and functional.
3. Verify appropriate access for all serviceable components such as belts, bearings, motors, and filters.
4. Visually inspect drivers, belts, access covers, guards, and enclosures. Fan belts and sheaves and pumps are to be properly aligned and tensioned without noticeable vibration.
5. Verify all seals and gaskets are undamaged and all mating surfaces meet to provide to ensure unit integrity.

1.7 Controls

Specifications shall require the contractor to comply with the following:

1. Verify that all control devices such as dampers and valves cycle freely without binding throughout the full operating range of the device.
2. Simulate safety shut-down conditions and verify that safety devices function as designed to protect the equipment, system, or devices from catastrophic failure.
3. Verify both the normal and emergency sequences of operation. Simulate operating parameters which cause the unit or system components to cycle, modulate or change position.
4. While operational verify the equipment, systems, or devices operate to achieve and maintain designed set-points.
5. Verify that graphics on front-end computers comply with Building Systems Control (BSC) standards including the display of actual and set-point values, supporting parameters such as secondary water supply temperature, pump status, outside-air conditions, calculated resets, flows, valve positions, static pressure, etc.
6. Witness startup and functional testing of variable frequency drives (VFD) including ramping parameters, fault management, minimum programmed speed, test operation with key pad and verification of the auto signal response.
7. For all VFDs ensure the following points are in trend with historian enabled:
 - % SPD
 - Power (kW or HP)
 - Frequency (Hz)
 - Command Speed

1.8 Electrical

Specifications shall require the contractor to comply with the following:

1. Visually inspect wiring, wire size, disconnect device, terminations, and conduit runs.
2. Inspect conduit pathways for conflicts with junction box covers or equipment service access points.

SECTION 23 05 13 - GENERAL PROVISIONS

3. Witness or conduct function and acceptance testing for all transformers, switchgear and related equipment.
4. Verify circuit and breaker information on equipment.

Part 2 Products

Part 3 Execution

END OF SECTION

SECTION 23 05 19 - METERS AND GAUGES**Part 1 General****Building Level Utility Metering and Data Collection**

Dedicated metering and meter data collection is required for each utility input to the building, to include: Electricity, Steam, Steam Condensate, Chilled Water, Hot Water, Natural Gas, and Domestic Water.

1. Installed metering must be Bacnet Network visible via the installed BAS or network IP connection. Data accumulation/trending must be enabled in the BAS if connected to the BAS.
2. It is the responsibility of the installation / controls contractors, the project engineer and the commissioning agent to validate the accumulating trend data.

Metering Units and Trend Intervals by Utility

1. Electric meters – kWh and kW, 5 minute interval data, IP network trends, represented in the Vanderbilt Meter Data Warehouse (BDX)
2. Chilled Water, Hot Water – gallons per minute, 5 minute trend interval
3. Steam – LBS/Hour, 5 minute interval trends should be established along with an additional hourly totalization trend.
4. Steam Condensate – pumped condensate is measured gallons, condensate flow trends will be hourly totalization trends.
5. Natural Gas – gas flow measured in cubic feet, 5 minute interval trends should be established along with an additional hourly totalization trend.

BTU Calculation and Energy Trends by Utility

1. Electric meters – all electric meters will be made visible Bacnet network visible via dedicate IP connection. The meter bacnet point will be identified and integrated into the “Meter Data Warehouse” (BDX)
2. Chilled Water – chilled water BTU will be calculated using measured flow data and the associated supply and return water temperatures. Calculated BTU values will be captured in 5 minute interval along with hourly and daily totalization trends.
3. Steam – steam BTU trends will be calculated using the BTU content of the steam at the pressure and temperature associated with the distribution point. Calculated BTU values will be captured in 5 minute intervals along with hourly and daily totalization trends.
4. Steam Condensate – steam BTU will be derived from the hourly totalization of pumped condensate in gallons. Calculated BTU values will be captured in hourly and daily totalization trends.
5. Natural Gas – natural gas BTU will be calculated using the site average heat content. Calculated BTU values will be captured in hourly and daily totalization trends.

STEAM FLOW, 1b/hr

CHILLED WATER FLOW, gpm

ELECTRICAL, kwh & kw (Refer to Section 26 27 13) NATURAL GAS, ccf

In those cases where multiple users or profit centers occupy the same building, provide utility cost sub-metering capability.

SECTION 23 05 19 - METERS AND GAUGES

Specify minimum and maximum flowrates for all hydronic, vapor and electrical meters.

Part 2 Products

Temperature & pressure test plugs shall be installed on each side of water side equipment that produce a temperature or pressure change but are not to supersede the placement of gauges stated herein.

2.1 Pressure Gauges for Hydronic Systems

1. 200 lb. range or less, 4" □ glycerin filled.
2. Greater than 200 lb. range, 6" □ glycerin filled.
3. Select gauges so that operating pressure falls within the middle 1/3" of gauge scale.
4. Provide each gauge with pressure snubber, Trerice model 872-2 or equal.
5. Gauges shall be mounted in such a way as to be easily readable from the floor.
6. Provide a 1/4" ball valve, Apollo 70-100 series or equal as a gauge cock.
7. Install a 1/4" brass ground joint union between gauge cock and gauge.
8. Gauges shall be Trerice, U.S. Gauge, Wika, Ashcroft or Marsh.
9. Gauges shall be installed at the following locations:
 - a. Suction and discharge of pumps.
 - b. Inlet and outlet of heat exchangers (water side).
 - c. Inlet and outlet of air handling units (water side).
 - d. Building entrance and exit on central plant chilled water systems.
 - e. As additionally shown on drawings.
10. Gauges shall have a guaranteed accuracy of 2% of scale range.
11. Piping from pressure tap to gauge shall be 1/4"sch 80 brass.
12. Pressure gauges shall be installed at a sufficient distance from the piping to allow removal without damaging the piping insulation or the gauge.

2.2 Pressure Gauges for Steam and Condensate

1. 200 lb. range or less 4" □
2. Greater than 200 lb. 6" □
3. Select gauges so that operating pressure falls within the middle 1/3 of the scale.
4. Use Trerice model 885 coil siphon on all steam gauges.
5. Use Trerice model 872-2 pressure snubber on condensate gauges.
6. Gauges shall be mounted so as to be easily readable from the floor.
7. Gauges shall be installed at a sufficient distance from the piping to allow removal without damaging the piping insulation or the gauge.
8. A 1/4" lb. globe valve shall be used as a gauge cock.
9. Gauges shall be installed at the following locations:
 - a. Steam coil inlet
 - b. Steam PRV inlet and outlet
 - c. Building entrance and exit
 - d. Discharge of condensate pumps
 - e. At heat exchangers and water heaters

SECTION 23 05 19 - METERS AND GAUGES

10. Gauges shall be bourdon tube type equal to Marsh Quality gauge with re-calibrator. Equals by U.S. Gauge, Wika or Ashcroft will be acceptable.

2.3 Thermometers

Thermometers for hydronic applications shall be 9” scale and selected so that the operating range falls within the middle 1/3 of the scale. Thermometers shall have adjustable angle heads and extension wells to match insulation thickness similar to the Trerice BX9. Thermometers shall be placed to measure the temperature of chilled or hot water entering and leaving building, across AHU coils, chillers, heat exchangers or similar devices. Thermo-wells in piping must contain a thermally conductive paste for proper readings.

Thermometers shall be installed in the discharge of each air-handling unit; these thermometers should be of the dial-type with 5-inch diameter, adjustable face. Select gauges so that operating pressure falls within the middle 1/3 of the scale.

PT test plugs shall be installed at the following location:

1. Suction and discharge of pumps.
2. Inlet and outlet of coils in air handling units.
3. Entering and leaving of chillers on chilled water and condenser water.
4. Inlet and outlet of converters.
5. Building entrance and exit of chilled water from the central plant.

2.4 Electric Meters and Metering

1. **Electric Meter Mains** shall be Electro Industries - Shark Series meters. These meters must be connected to the Vanderbilt Facilities Network via Bacnet/IP.
 - a. Multiple Shark Meters - with approval from the Vanderbilt Metering Coordinator, multiple Shark meters located within the same gear or location a may be connected with a single data drop using a Bacnet/IP ProtoComm Gateway.
 - b. Sub-metering – gear level sub-metering may be provided by the switchgear manufacturer. These sub-meter devices must be Bacnet visible to the Vanderbilt Facilities Network.
 - c. Sub-metering devices may be provided by the switchgear manufacturer that communicate via serial connection but it is the responsibility of the gear manufacturer/supplier to provide a serial to bacnet/IP gateway making each of the connected devices Bacnet visible.

2.5 Flow Meters

1. **Steam Meters** shall be a Veris Accellabar with integrated temperature and pressure sensors for compensated flow measurement.
 - a. Maximum and minimum flow rates must be specified by the project engineer.
 - b. Meter selection and measurement range must be verified by the project engineer and Vanderbilt Metering Coordinator.

SECTION 23 05 19 - METERS AND GAUGES

- c. Steam metering associated with the Powerhouse requires transmitters by Foxboro or Rosemount with HART compatible 4-20ma signal output.
2. **Chilled Water, Hot Water & Steam Condensate Meters** shall be Flexim Ultrasonic with maximum +/- 1% inaccuracy and must be configured for Bacnet MS/TP communication.
 - a. Flexim Ultrasonic may be selected in single or dual channel configuration as appropriate for the project application.
3. **Natural Gas Meters** shall be a vortex-type, multi-variable flow meter configured for Bacnet/MSTP communication.
 - a. Acceptable manufacturer: Vortek Pro-V
4. **Domestic Water Meters** – for use measuring building domestic water, plant make-up water, blow-down or sewer deduct water.
 - a. Acceptable Manufactures include: Sensus or approved equal, with local flow indication and pulse output for connection to the local BAS. As required for the project, optional RF remote reading capability may be specified.

Part 3 Execution

All flow meters must be selected installed in accordance with the manufactures recommendations to ensure design accuracy. Installation specifics include but are not limited to meter orientation, cable shielding and distance, and installation with the necessary straight pipe dimensions up and down stream of the meter.

Chilled Water, Hot Water and Condensate flow meters are to be provided with local displays and connected to the building automation system via BACnet MS/TP. When multiple flows are required, dual channel processors are acceptable.

END OF SECTION-

SECTION 23 05 23 - GENERAL DUTY VALVES FOR HVAC PIPING

Part 1 General

All valves, cocks and fittings of the same type shall be furnished by the same manufacturer. Remanufactured valves are not acceptable.

Part 2 Products

Valves shall be designed for repacking under full line pressure when the valve is in the full open position. The pressure/temperature rating of the valve and associated components shall not be less than the requirements for the pipe and fittings used on the same service and shall be as recommended for the intended service.

Valves with stems higher than 7 feet above the normal accessible working floor in mechanical rooms shall have chain operators, sprocket guide and chain hook.

Gate valves 4" and larger for steam service shall have a 3-valve bypass and drain. The bypass valve shall be a globe valve. It shall be 1/3 the size of the main valve.

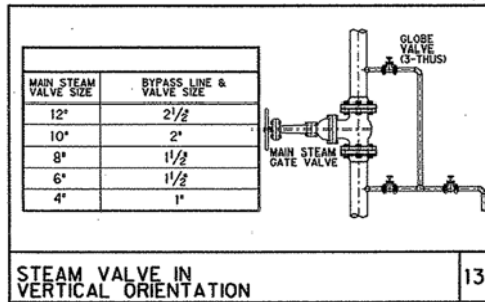
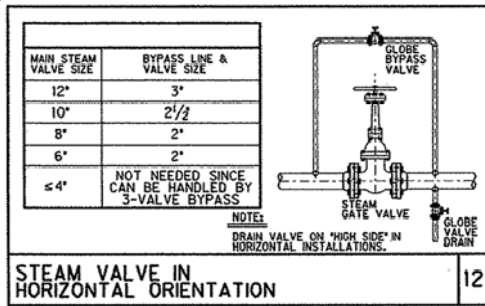

Valve tags shall be provided with each valve and secured with an s-hook to permanently attach the number to the valve. The valve number shall coordinate with a valve schedule so that the number of the valve can be located and identified on the drawings.

Valve stems shall be pointed up where possible. If it is not possible, valve stems shall be pointed to the horizontal.

Valves shall be of the extended-neck design to allow for the installation of full-thickness insulation over flanges. Provide rubber end-caps on all exposed valve stems under 7' of rubber or other soft material to prevent bump hazards.

SECTION 23 05 23 - GENERAL DUTY VALVES FOR HVAC PIPINGValves (buildings outside central plant):

For high-pressure steam and condensate 2" and smaller: Class 800 forged steel, socket weld ends. For high-pressure steam and condensate 2½" and larger: Class 300 cast steel, flanged, OS&Y.

For low-pressure steam and condensate, 2" and smaller, 300 psid WOG rating: union bonnet bronze, screwed ends. For low-pressure steam and condensate 2½" larger: Class 125, cast iron flanged, OS&Y.

For circulating water systems 2" and smaller: 600 psid bronze ball valve, chrome-plated ball with screwed ends. Use copper "x male adapter" to connect copper tubing to valve. Valves on insulated piping shall have an insulated stem extension similar to Nibco's "Nib-Seal" to allow the handle to clear the insulation.

For circulating water systems 2½" and larger: Class 125 cast iron flanged gate valves for shut-off or class 125 flanged cast iron ball valves equal to American Valve series 4000.

Butterfly valves may only be used with the expressed permission of the project manager. Any butterfly valves used in Vanderbilt projects shall be of the high performance type. Valves 6" and larger shall have gear operators. Butterfly valves may be used in the common bridge on chilled water.

Solder-less valves and pipe fittings such as those manufactured by Viega and 'Nibco' are not allowed unless expressly permitted by the Vanderbilt Project Manager. All pipe should be soldered, brazed, or welded as appropriate.

Part 3 Execution

Installation shall be made so that the valve can be fully opened and have a minimum clearance of 6" beyond valve stem end at the full open position and will include sufficient clearance for removal of stem for repair.

Provide valves to isolate risers and/or major branches from mains, each piece of equipment and/or fixture.

- a. Globe-type control valves shall have stainless steel trim and spring-loaded teflon packing.
- b. Ball-type valves used for control applications shall have teflon seats, seals and stem packing.
- c. Combination automatic flow balancing and shut-off valves with integral unions may be used on terminal boxes and fan-coil units provided sufficient installation and maintenance clearance is available.
- d. Important: vendors of air-handling units, fan coil units, reheat boxes, and energy recovery units shall be referred to these valve specifications.

-END OF SECTION-

SECTION 23 05 53 - IDENTIFICATION FOR HVAC PIPING AND EQUIPMENT**Part 1 General**

All insulated piping shall be stenciled to indicate size, contents, and direction of flow. Steam and condensate shall also be stenciled to indicate pressure. All equipment shall be identified with a Plant Operations Cut Tag with sequence unit numbers, and located in a visible location on equipment.

Install 2" diameter brass or aluminum valve tags marked with the valve number and the system they serve. Example: 25# CHWR. Generate a valve list with valve position, location, and purpose to be included in the Operations and maintenance manuals and post a laminated list in all mechanical rooms.

A Warning Tag advising that a unit could start anytime by computer automation shall be located in a visible location. All devices monitored by a building automation system (BAS) should have the system point address affixed to it.

Where previous naming conventions are already present, engineer shall continue with existing on construction drawings subject to project manager discretion.

Part 2 Products**Part 3 Execution**

END OF SECTION-

SECTION 23 07 00 - HVAC INSULATION

Part 1 General

Where the temperature difference between the environment and the surfaces of piping, ductwork, and equipment are conducive to energy loss or condensation, thermal insulation is required. Where condensation is possible, provide a vapor barrier.

Ductwork with acoustical liner need not be insulated externally.

Pipe that is insulated outdoors, inside tunnels, or subject to abuse shall have smooth-aluminum jacketing, .016 inches thick minimum.

Use rigid insulation for ductwork and equipment in mechanical rooms or other areas unless concealed.

Where service access is required for valves or other equipment underneath insulation, provide a means for temporary removal of the insulation without its destruction. Use prefabricated removable jacket for valve insulation on steam isolation, by-pass, and pressure reducing valves and condensate valves larger than 2-1/2 inch.

Do not insulate valve stems or hydronic expansion tanks.

Extend piping insulation without interruption through walls and floors. Install protective sheet metal insulation shields at hanger locations for all piping.

Insulate all piping, ductwork, and equipment subject to producing condensation and as required to maintain thermal properties.

Install insulation to allow clearances and access for servicing and maintenance to all equipment. Nameplates or other tags, which provide equipment data, shall not be covered by insulation.

Part 2 Products

Removable jacketing for valves shall utilize the following components as manufactured by Auburn Manufacturing, Inc. or equivalent:

1. Inner lining: AMI GL2025-XX-9383 heat treated fiberglass cloth (<450F).
2. Insulating material: AMI AM1000 needled fiberglass mat (<1000F).
3. Outer cover: AMI AGL2025 aluminum foil laminated fiberglass cloth.
4. Fastener: AMI GLR188HD fiberglass, draw string.

Rigid fiberglass with an all-service-jacket (ASJ) is preferred for all piping applications.

The use of flexible elastomeric insulation is limited to refrigerant piping and cold surface applications provided it meets NFPA 90 smoke developed/flame spread rating of 25/50 only if approved by the Project Manager on a case-by-case basis.

Vapor barriers may be of aluminum foil or mastic.

Pipe fitting insulation shall have covers equivalent to those manufactured by Zeston.

SECTION 23 07 00 - HVAC INSULATION

On 2" and larger piping insulated with fiberglass insulation, a foamglass saddle equal in thickness to the insulation shall be installed. The saddle shall be 18" long and shall cover 180° of the pipe. A 16-gauge sheet metal shield shall be placed between the hanger and saddle.

Where metal jacketing is required, install jacket with seam on the bottom of the piping. Secure jacketing with 3/4" wide stainless steel bands on 18" centers.

Blanket-type Insulation:

Provide blanket-type insulation with factory-reinforced foil faced and Kraft vapor barrier on the following:

- a. Unlined supply and outside air ducts concealed from view.
- b. Reheat duct coils and coils at terminal boxes.
- c. Ceiling diffuser bodies in unventilated ceiling spaces.

Board-type Duct Insulation:

Provide rigid glass fiberboard-type duct insulation with factory reinforced foil faced Kraft vapor barrier on the following:

- a. Unlined supply and outside air ducts within equipment rooms.
- b. Apparatus casings.
- c. Ducts exposed to weather are discouraged. They may only be used only with specific approval of the project manager. If allowed, duct tops must be sloped to eliminate rainwater ponding. Cover duct insulation with glass mesh embedded and adhered to insulation using air drying weatherproof plastic fabricated cutback asphalt adhesive and finish with two coats of gray color flexible fire-retardant protective coating, equal to Armstrong "Insulcor."

Piping Insulation:

Insulation for pipe, valves, and fittings shall be as follows:

Pre-molded, rigid fiberglass insulation will be used on the following services:

1. Refrigerant piping above freezing temperature – 1½" thick.
2. Refrigerant piping below freezing temperature – 2" thick.
3. Chilled water piping – 1½" thick.
4. Heating hot water piping, run-outs to terminal units (12 ft. or less), 2" and less – ½" thick; 1" and less – 1" thick; 1¼" to 2" – 1" thick; 2½" and greater – 1½" thick.
5. Steam condensate piping, 2" and under – 1½" thick; 2½" and greater – 2" thick.
6. Steam piping to 30 psi, 2" and under – 1½" thick; 2½" and greater – 2" thick.
7. Steam piping 31 to 60 psi, 1" and under – 2" thick; 1¼" to 4" – 2½" thick; 5" and over – 3" thick.

Mineral wool insulation will be used on the following service:

1. Steam piping 61 to 425 psi, 2" and under – 2½" thick; 2½" to 4" - 3" thick; 5" and over – 3½" thick.

SECTION 23 07 00 - HVAC INSULATION

2. Heating hot water piping, run-outs to terminal units (12 ft. or less), 2" and less – ½" thick; 1" and less – 1" thick; 1¼" to 2" – 1" thick; 2½" and greater – 1½" thick.
3. Steam condensate piping, 2" and under – 1½" thick; 2½" and greater – 2" thick.
4. Steam piping to 30 psi, 2" and under – 1½" thick; 2½" and greater – 2" thick.
5. Steam piping 31 to 60 psi, 1" and under – 2" thick; 1¼" to 4" – 2½" thick; 5" and over – 3" thick.

Mineral wool insulation will be used on the following service:

2. Steam piping 61 to 425 psi, 2" and under – 2½" thick; 2½" to 4"- 3" thick; 5" and over – 3½" thick.

Where new insulation is installed on existing piping systems, the new insulation thickness may match adjacent piping insulation thickness prior approval by the Owner.

Provide steel pipe covering protection saddle insulation shields on steam and condensate piping when roller hangers are utilized. The thickness of the insulation shields shall be equivalent to the insulation thickness.

Part 3 Execution

END OF SECTION-

SECTION 23 09 13 - CONTROLS AND INSTRUMENTATION**Part 1 General**

1. All building automation controls (BAS) shall be of the direct digital control (DDC) type. Field devices and controllers shall use BACnet. All package controllers (chiller controllers, VRF system controllers, Packaged DX system controllers, Variable Frequency Drives) shall be provided with BACnet interface to the building automation system.
2. All valve and damper actuators shall be electronic for all new or major renovation projects. Subject to approval by the VU Project Manager, certain applications or specific renovations may require pneumatic actuators. Where pneumatic actuation is permitted, provide duplex air compressors in locations accessible for service and convenient belt replacement and air piping shall be hard drawn copper tubing (Type L) with soldered or compression fittings. Soft drawn copper tubing may be used in concealed locations. If used above inaccessible ceilings, thermostat drops shall be copper; not polyethylene. Flame retardant polyethylene tubing may be used inside control panels. Above accessible ceilings, bare polyethylene may be used above accessible ceilings provided penetrations of fire rated partitions are 'sleeved' by routing tubing through EMT conduit. Above inaccessible ceilings and equipment rooms use copper tubing or polyethylene in EMT conduit. Drops to wall mounted thermostats shall be two tube sheathed polyethylene.
3. Each building temperature control system shall be connected to the University-wide building automation system (BAS) using BACnet IP protocol unless directed by the VU Project Manager and report to Vanderbilt University's Building System Control (BSC) department located at the VU Power House.
4. Where remote from the Building Control Loop (BCL) distribution network, the cost of extending the Ethernet fiber is to be identified for the Project Manager for evaluation.

Part 2 Products**2.2 Approved Manufacturers for centrally monitored BAS Systems**

1. Johnson Controls Metasys
2. Automated Logic.

2.3 Graphics

1. Install color graphics on the existing servers at the Building Systems Control (BSC) at the VU Power Plant and provide standard graphic images for each component (fans, temperature sensors, VFD status/alarm/Hz, differential pressure sensors, filter differential pressure, etc.) and system (air handling units, exhaust fans, fan coil units, air terminal units, etc.) controlled and/or monitored by the building's FMS. The graphics package shall include building floor plans and component pages shall have system information. Submit custom graphic layout sketches to

SECTION 23 09 13 - CONTROLS AND INSTRUMENTATION

2. Project Manager for Plant Operations review prior to programming.
3. Graphics and acronyms for variables shall be in accordance with standards established by Plant Operations. Set alarms as directed by Plant Operations.

2.3 Control Valves

1. All water control valves sized 3" and smaller are to be globe-type or characterized ball-type control valves with threaded or flanged ends, stainless steel trim and self-adjusting spring loaded packing. Size modulating water valves for minimum of 2 PSI water pressure drop or as indicated on drawings and with equal percentage characteristics. All control valve bodies shall be no more than two pipe sizes smaller than the run out piping. Valves sized 4" and larger may be butterfly valves.
2. Control valves shall fail 'closed'; except preheat coil control valves (steam or hot water) shall fail open.
3. Low pressure steam control valves shall have stainless steel stem with removable composition disc and self-adjusting spring loaded packing.
4. Medium and high pressure steam control valves must have stainless, double-seated, steel seats and disc with Teflon packing. Modulating steam valves to have modified linear characteristics. Valves shall have minimum ANSI Class VI shutoff rating, manufactured by Valve Solutions, Inc. (VSI) or approved equal.

2.4 Building Control Panels

1. Each Building Control Panel shall have backlit display interfaces as follows:

Each air handling unit control panel in each mechanical room shall have a display panel for interrogating the following information:

- *Outdoor air temperature*
- *Outdoor air humidity*
- *Outdoor air dewpoint*
- *Return air temperature*
- *Mixed air temperature*
- *Supply air temperature*
- *Supply duct static pressure*
- *Supply duct static pressure set-point*
- *Chilled water valve position*
- *Hot water valve position*
- *Minimum outside air damper position*
- *Maximum outside air damper position*
- *Return air damper position*

SECTION 23 09 13 - CONTROLS AND INSTRUMENTATION

- *Relief air damper position*
- *Supply fan VFD speed (Hz or %)*
- *Return fan VFD speed (Hz or %)*

One control panel in the building's main mechanical room shall have display panel for interrogating the following information:

- *Outdoor air temperature*
- *Outdoor air humidity*
- *Outdoor air dewpoint*
- *Plant chilled water supply flow*
- *Plant chilled water supply temperature*
- *Plant chilled water return temperature*
- *Building chilled water temperature control valve setpoint*
- *Building chilled water supply temperature*
- *Building chilled water differential pressure-1 (across remote A/C unit cooling coil)*
- *Building chilled water differential pressure-1 setpoint*
- *Building steam flow (if installed as alternate)*
- *Building hot water supply temperature*
- *Building hot water return temperature*
- *All A/C unit supply fan status*
- *All A/C unit return fan status*
- *All exhaust fan status*

Part 3 Execution

1. The BAS must be arranged so that an operator can view all building points from any local panel. In each mechanical room, at least one panel shall have an active display of all control objects in that room.
2. Remote monitoring points shall be grouped logically on existing BAS software maps as directed by the Plant Operations control group.
3. The BAS must monitor all steam, chilled water, domestic water, and electricity utility meters when installed. Refer to Section 15170, Meters and Gauges for connection requirements.
4. 24-volt electric thermostats are preferred for fan coil units (FCU) in dormitories. All thermostats serving FCU shall be wall-mounted with temperature scale and adjustable set-points. Wall-mounted fan speed control switches shall be located near the thermostat; fan switches serving rooms having continuous fresh air supply, shall have an 'OFF' position; otherwise, FCU fans shall run continually. See Section 23 82 00, Water Terminal Units for specific FCU motor control arrangements.
5. New FCU's shall have 24 volt electric thermostats and valve actuators. Subject to review and approval by the VU Project Manager certain renovation applications may require pneumatic actuators.
6. Electric thermostats accessible by occupants shall operate at a maximum voltage of 24V. Equipment operating at higher voltages shall have 24V transformers and relays.

END OF SECTION-

SECTION 23 09 93 - SEQUENCE OF OPERATION**Part 1 General**

1. The contract drawings for each project shall have a sequence of operation written in layman's terms which describes the prescribed operation, interlock, and interface requirements with the university-wide building automation system (bas) for all mechanical systems such as air handling units, pumps, exhaust fans, terminal units, unit heaters, convectors, etc. The development of the sequence of operations shall be consistent with current plant operations control strategies. A draft of this sequence shall be provided to campus planning for review with plant operations prior to programming. The contractor shall coordinate a meeting with the owner and designer to review scope and programming.
2. The written sequence of operation must appear on the pertinent control schematic drawing along with an input/output schedule of all points of control.
3. Identification of various mechanical equipment and control elements shall agree with the nomenclature of associated control drawings and wiring diagrams.

Part 2 products**Part 3 execution**

1. The written sequence of operations must also be included in control system shop drawing submittals and in the owner's maintenance manuals.
2. Install control sequences and diagrams on prominent walls in mechanical rooms containing control panels. These documents shall be laminated in clear plastic and attached to the wall with hooks for removal, use, and replaced on the wall.

General note: all setpoints and time durations shall be user adjustable.

Ahu control sequence**Supply and return fan control**

Minimize access space required for AHU change-out. At change-out 6'0" door may be sufficient, if original unit is custom and replacement is of knock down construction capable of field assembly.

Supply fan shall be started by any of the following:

- bas command automatically or by operator.
- vfd "hand" position.

Supply fan shall be stopped by any of the following:

- Bas command automatically or by operator.
- Vfd "*hand*" position.
- Hardwired safeties.
- Fire alarm.

Return fan and interlocked exhaust fans shall start/stop via hardwire interlock with supply fan.

SECTION 23 09 93 - SEQUENCE OF OPERATION

Whenever the ahu is de-energized:

- Outside air dampers (min and max) shall be closed.
- Relief damper shall be closed.
- Return damper shall be open.
- Chilled water valve shall be closed.
- Preheat hot water valve shall be open.
- Interlocked exhaust fans shall be off.
- Duct mounted smoke dampers shall be closed.

Whenever the ahu is energized, the following sequence shall take place:

- Minimum outside air damper shall open.
- Duct fire/smoke dampers shall open.
- When min oa and fire/smoke dampers are proven open via end switches, supply fan and interlocked return fan and exhaust fans shall start.
- When supply fan start is proven, supply air temperature control shall be enabled.

Supply air temperature control

Unit shall go into economizer mode when either of the following conditions is true for 10 minutes:

- T-*oa* is less than t-*cc*
- or-
- Oa dewpoint is less than 52f and t-*oa* is less than t-*ra*.
 - Minimum outside air damper shall remain open.
 - Maximum outside air and relief air dampers shall open fully.
 - Return damper shall close.
 - Chilled water valve shall continue to modulate to maintain supply air temp t-*sa* setpoint.

As t-*sa* begins to fall below setpoint:

1. Modulate the chilled water valve closed.
2. Upon continued fall in t-*sa* below setpoint and after chilled water valve has closed fully, maximum outside air and relief air dampers shall begin to modulate closed and return air damper shall begin to modulate open to maintain t-*sa* setpoint.
3. Upon continued fall in t-*sa* below setpoint and after maximum outside air and relief dampers have closed fully, and return air damper has opened fully, preheat hot water valve shall modulate to maintain t-*sa* setpoint.

As outside air temperature rises and t-*sa* rises above setpoint:

1. Preheat hot water valve shall modulate closed.
2. Upon a continued rise in t-*sa* above setpoint, maximum outside air and relief dampers shall begin to modulate open and return damper shall begin to modulate closed to maintain t-*sa* setpoint.
3. Upon a continued rise in t-*sa* above setpoint, and after maximum outside air and relief dampers have opened fully and return damper has closed fully, chilled water valve shall modulate open to maintain t-*sa* setpoint.

SECTION 23 09 93 - SEQUENCE OF OPERATION

Unit shall go into mechanical cooling mode when either of the following conditions are true for 5 minutes:

- Oa dewpoint is greater than 53f
- or-
- T-oa is greater than t-ra.
 - Minimum outside air damper shall remain open.
 - Return damper shall open fully.
 - Maximum outside air and relief air dampers shall close.
 - Chilled water valve shall modulate to maintain t-sa setpoint.

Supply air temperature reset control

Bas shall reset the t-sa setpoint linearly according to schedule below.

- If h-ra exceeds 55f dewpoint, reset shall be disabled. When h-ra falls below 53f dewpoint, reset shall be enabled.

Oat t-sa

80f - setpoint

40f - setpoint + 5

Supply fan and return fan speed control

- Supply fan vfd speed shall modulate to maintain spt setpoint.
- Bas shall read velocity pressure at supply and return fans and calculate airflow.
- Return fan vfd shall modulate speed to maintain a set differential between supply and return air airflow (differential is equal to minimum outside air flow listed in ahu schedule sheets).
- If differential airflow is greater than setpoint, return fan shall increase speed, to increase return air flow and reduce differential.
- If differential airflow is less than setpoint, return fan shall decrease speed, to decrease return air flow and increase **sequence of operation** (revised 7-6-2017) 23 09 93

Differential.

- If supply duct static pressure sp-hl exceeds high limit, ahu shall stop and send alarm signal.
- If return duct static pressure sp-ll falls below low limit, ahu shall stop and send alarm signal.

Supply fan static pressure reset

Bas shall monitor vav box damper position for all boxes served by the ahu.

- When any box damper is greater than 95% open, bas shall increase static pressure setpoint spt until max damper position of any box is less than 90%.
- When all box dampers are less than 80% open, bas shall decrease static pressure setpoint spt until at least one box is greater than 85% open.
- Bas shall reset supply duct static pressure spt at a rate of 0.1" w.c. every 10 minutes.
- Bas shall be able to exclude any selected boxes when determining box damper positions.
- Bas shall identify and display vav box that is at highest box damper open position.

SECTION 23 09 93 - SEQUENCE OF OPERATION**Filters**

Bas shall monitor differential pressure across filter banks and initiate an alarm if pressure drop exceeds high limit setpoints.

Freeze protection

If temperature t_{hc} falls below alarm setpoint;

- Return damper shall open fully.
- Maximum outside air and relief dampers shall close fully.
- Preheat hot water valve shall open fully.
- Initiate an alarm.

If the temperature low limit t_{ll} upstream of the cooling coil falls below 36 f:

- Stop supply fan and interlocked fans.
- Open the chilled water valve 20%.
- Initiate an alarm.

Variable air volume box control cooling

- Upon a rise in room temperature above cooling temperature setpoint, box air damper shall modulate open.
- Upon a fall in room temperature below cooling temperature setpoint, box air damper shall modulate closed until it reaches minimum cooling air flow.

Heating

- Upon a continued fall in room temperature below heating temperature setpoint, box air damper shall stay at minimum air flow and hot water valve shall begin to modulate open.
 - Hot water valve open position shall be modulated so that discharge air temperature shall not exceed high limit setpoint.
- Upon a continued fall in room temperature below heating temperature setpoint and after hot water valve is fully open or discharge air temperature has reached high limit setpoint, box air damper shall begin to modulate open.
 - Hot water valve position shall be modulated to not exceed discharge air temperature high limit setpoint as box air damper modulates.

Setpoints

If occupancy sensor is used in spaces served by box, the box shall adjust cfm to maintain “*unoccupied*” temperature setpoints when

Space is unoccupied. If box has “*unoccupied*” cfm settings per box schedule, bas shall adjust box to those setpoints.

Fan coil unit control cooling

- Upon a rise in room temperature above cooling temperature setpoint, unit chilled water valve shall modulate open.
 - Chilled water valve open position shall be modulated so that discharge air temperature shall not exceed low limit setpoint, 56f.
- Upon a continued rise in room temperature above cooling temperature setpoint and after chilled water valve is fully open or discharge air temperature has reached low limit setpoint, unit fan shall begin to modulate faster speed.

SECTION 23 09 93 - SEQUENCE OF OPERATION

- Upon a fall in room temperature below cooling temperature setpoint, unit fan shall modulate slower until it reaches minimum cooling air flow (speed).
 - Chilled water valve open position shall be modulated so that discharge air temperature shall not exceed low limit setpoint, 56f.

Heating

Upon a continued fall in room temperature below heating temperature setpoint, unit fan shall stay at minimum air flow (speed) and hot water valve shall begin to modulate open.

- Hot water valve open position shall be modulated so that discharge air temperature shall not exceed high limit setpoint, 95f.
- Upon a continued fall in room temperature below heating temperature setpoint and after hot water valve is fully open or discharge air temperature has reached high limit setpoint, unit fan shall begin to modulate faster speed.
 - Hot water valve position shall be modulated to not exceed discharge air temperature high limit setpoint 95f.

Setpoints

- If occupancy sensor is used in spaces served by box, the box shall adjust cfm to maintain “*unoccupied*” temperature setpoints when space is unoccupied. If box has “*unoccupied*” cfm settings per box schedule, bas shall adjust box to those setpoints.
- Minimum fan speed shall be user adjustable as an eight hour timed override.

END OF SECTION-

SECTION 23 20 00 - HVAC PIPING AND PUMPS**Part 1 General**

1. Contractor shall submit pipe and fittings for approval prior to installation. Pipe and fittings shall be clearly marked with manufacturer's name, weight, and classification or working pressure.
2. Fire protection system shall meet requirements of National Fire Protection Association as outlined in NFPA pamphlets No. 13, 14, 20 as well as State and local code requirements.
3. 'Burn permits' approved by the VU Project Manager are required prior to pipe assembly utilizing open flames in existing facilities.

Part 2 Products

1. Circulating Water Piping shall be type "L" copper with sweat connections for nominal pipe sizes 2-inch or less. Larger piping shall be steel, standard wall, with butt weld fittings.
2. All condensate piping through 10" size shall be schedule 80 and all steam piping shall be seamless schedule 40. Fittings for all steam and condensate 2½" and larger shall be butt weld, wall thickness to match pipe. Fittings for 2" and smaller for high pressure steam piping and condensate piping 30-lb. and above, shall be 3000# forged steel socket weld. Fittings for low-pressure steam and condensate shall be 300# screwed malleable iron. 2" and smaller connections to welded steam and condensate lines shall be welded construction through the first shut-off valve.
3. "Weld-O-Lets" may be used for branch connections if the branch pipe is at least one size smaller than the main. Saddle connections may be utilized on condenser water systems. Dielectric unions shall be used at junctures between steel and copper pipe.
4. In hydronic systems, do not use Bullhead Tees unless approved by the Project Manager.
5. Threaded joints shall be made up using ribbon "Teflon" pipe sealant or pipe thread sealing compound.
6. On all domestic water lines located under slabs use Type "K" seamless copper tubing.
7. Do not use steel or cast iron fittings on copper piping systems.
8. Underground steam systems shall be Class A, drainable, dryable, testable systems equal to Thermacor Duo-Therm 505. Underground condensate, hot water, and chilled water piping shall be Thermacor Ferro-Therm or approved equal.
9. On steel piping for direct buried systems use welded joints.
10. Provide cleanable strainers "Y" type on all pump suction and upstream of control valves. Water strainers shall have fine mesh startup strainers; once cleaned, install monel 20 mesh screens. All strainers shall be provided with blow-down piping to nearest floor drain.
11. Provide all high point vents with pigtail drain line.

SECTION 23 20 00 - HVAC PIPING AND PUMPS

12. End suction pumps shall not be used if the inlet size is greater than 3" size. Horizontal split-case pumps shall be used above 3" suction size. Pump casings are not to be insulated with removable Armaflex. All pumps shall have a minimum ¾" deep drain-pan and piping to capture all pump components and connection flange condensation. Insulation must be applied to pump flanges or other components that over-hang a drain pan.
13. Each drip-pan shall have an appropriate connection for drainage piped to the nearest floor drain. The drain piping shall be routed to avoid a 'tripping' hazard.
14. Rooftop air handling unit condensate drains shall be minimum type M copper.

Part 3 Execution

1. Provide chromium-plated escutcheon plates for exposed un-insulated pipes projecting through walls or floors in finished spaces. Mechanical rooms and janitors closets are not considered finished space.
2. Pipes are not to be hung or supported by pumps or other operating equipment.
3. Provide unions or flanged connections at all equipment connections, control valves, traps. Do not conceal unions or flanges. Provide insulation but insure that flanges or unions are identifiable.
4. All underground steam and condensate welding shall be x-ray examined and all defective welds corrected and x-rayed again.
5. All welding shall be done by certified welders according to ASME Power Piping Code. Welds shall be appropriately stamped by the welder who performed the work. All welds shall be 100% penetration and subject to radiographic examination by the owner. If welds are found upon examination to be faulty, cost of repair and examination shall be paid by contractor. Welding procedure specifications, welding procedure qualification records and welder operator qualifications shall be submitted before any welding is performed.

END OF SECTION-

SECTION 23 22 00 - STEAM SPECIALTIES**Part 1 General****1.01 Scope**

Special devices are required for steam systems to insure proper operation, condensate flow, and expansion.

Part 2 Products

1. For condensate, Steam Traps are required of the float and thermostatic or bucket type sized for 2 times the capacity of the served equipment. Valved bypasses are required around each steam trap.
2. At each control valve and steam trap, Y-Type Strainers are required with removable brass strainer baskets and blow down valve.
3. To protect the building steam systems and specific equipment, Pressure Reducing Valves with pilot operators, iron body, and stainless steel trim are required.
4. Pressure Relief Valves of ASME design shall protect building systems and equipment from overpressure.
5. Vacuum breakers are required for all steam heating coils.

Part 3 Execution

1. The contract drawings shall indicate the capacity, in LBS/HR, of all steam traps.
2. The discharge of strainer blow down shall be directed to a floor drain; pressure relief valve discharge must terminate to the building exterior using drip-pan elbows with piped drain to floor drain.
3. Dual pressure reducing stations of 1/3 to 2/3 capacity shall be installed where summer/winter steam load swings are present.
4. Steam to water heat exchangers shall have flanged connections on the water side.
5. All traps shall be a minimum of 18" below heat transfer equipment being serviced.

END OF SECTION-

SECTION 23 22 23 - CONDENSATE PUMPS & RECEIVER SETS**Part 1 General****1.01 Scope**

Where required by elevation or existing condensate system pressures, condensate pumping equipment is to be installed.

Part 2 Products

Condensate pumping equipment shall be of the packaged design with cast-iron receiver, close-coupled bronze-fitted duplex pumps, electric alternator, gauge glass, and thermometer. Steam powered pumps are also acceptable. Pump selection shall prevent cavitation at design temperature, and have mechanical seals and non-overloading motors. All receiver tanks shall have vents and drains. All duplex systems shall have pump inlet shutoff valves.

Part 3 Execution**3.01 Condensate pumps and receivers**

1. Condensate pumps and receivers shall be installed above finished floors and have adequate floor drains for handling maximum building condensate flow in the event of pump failure. The necessary valves shall be installed to divert the building condensate directly to these floor drains.
2. Pumping equipment shall be installed with alternating pump motor starters and pump failure status alarm or contacts for connection to Vanderbilt's University-wide Building Systems Control (BSC) where applicable. Contact the Supervisor of BSC Operations at 322-2621 with questions.
3. Pumping installations shall have discharge check valves for each pump within an associated discharge isolation valve.
4. Discharge piping from each electric condensate pump shall have an automatic flow limiting device set for design flow.

END OF SECTION-

SECTION 23 23 00 - REFRIGERATION PIPING**Part 1 General**

1. All refrigeration piping shall be designed in accordance with ARI and ASHRAE requirements. Refrigeration piping for HVAC shall be shown on the contract drawings with length of piping, sizes, traps and all appurtenances indicated.
2. PRIOR to Substantial Completion, a Start-up Report shall be submitted to the Project Manager for each system indicating refrigerant pressures at the compressor, the evaporator suction, and the discharge; indicating compressor running load amperage; and indicating refrigerant charge and lubricant oil quantity. Include certification that leak test and dehydration tests have been performed and signatures of Plant Operations' witnessing the start-up.
3. Each refrigeration circuit shall have service valves, moisture indicator and filter-dehydrator.

Part 2 Products

Refrigeration piping shall be type "ACR" copper with wrought copper fittings; all joints shall be made with high temperature hard solder with a minimum melting point of 1,125 Deg-F with joints purged with carbon dioxide or nitrogen.

Part 3 Execution

1. Install traps in vertical suction lines at intermediate levels to insure adequate oil return to compressors located above the evaporator.
2. Each system shall be dehydrated with a vacuum pump to 0.2" HgA for twelve hours. After dehydration, each system shall be leak tested with inert gas to 1.5 times design pressure, then evacuated to vacuum, charged with refrigerant and tested with a halide leak detector.
3. During installation, refrigerant piping must be capped for protection; piping found open to the atmosphere removed at the installer's expense.
4. Refrigerant piping wall penetrations must be protected with insulation to avoid contact with masonry materials.

END OF SECTION-

SECTION 23 30 00 - AIR DISTRIBUTION**Part 1 General**

1. All low-pressure ductwork as defined by SMACNA shall be sealed to Class "C" requirements. All medium pressure ductwork shall meet SMACNA Class "A" sealing requirements. These requirements apply to supply, return and outdoor air ductwork.
1. Where outdoor-air, pre-heat coils are not installed, ductwork shall be designed and installed to properly mix outdoor and return air to protect the coil from freezing. If spatial considerations make this impractical, Air Blender manufactured devices shall be installed to guarantee blending of the air.
2. All air-distribution inlets and outlets are to have balancing dampers and shall be constructed of aluminum with the exception of wall registers within five feet of finished floors. In which case, industrial type steel registers shall be used.
3. The contract drawings shall indicate minimum and maximum outside air quantities for each AHU.
4. All air distribution systems are to be designed for a maximum sound NC LEVEL of 30 within each space. Many times air distribution noise results from return air inlets located near air handling units or fans. Sound traps, duct liner, or sufficient ductwork offsets shall be incorporated to reduce noise.
5. All air distribution systems shall have ducted-return air.

Part 2 Products

1. Test all ductwork for leakage in accordance with "System Pressure Testing for Leaks", published by United Sheet Metal Division of United McGill Corporation. The following are not required to be leakage tested:
 - Flexible ductwork.
 - Ductwork connections to air distribution devices less than 4 feet from the main, sub- main, or branch duct connection.
2. Pressurize all installed duct systems to maximum pressure for fabrication classification. Total allowable leakage shall not exceed one percent of air handling capacity of system. If system is tested in sections, add leakage rates for individual sections to determine leakage for the whole system. All obvious leaks shall be sealed.
3. All longitudinal and transverse joints, seams and duct sidewall penetrations, regardless of pressure classification, shall be sealed with two-part Hardcast RTA-50 duct sealer or rolled elastomeric duct sealant Hardcast 1602. Follow SMANCA Table 1-2, Seal Class A for all supply, return and exhaust ductwork. Sealant shall not be used to patch manufacturing defects.
4. All exhaust and ventilation fans shall be direct driven unless manufacturer's availability and expense deem otherwise. For fans that are belt driven, an automatic belt tensioner is required.
5. For ceiling applications, adjustable, louver-faced diffusers are preferred; sizes based on horizontal throw and vertical projection. When installed in modular ceilings, louver-faced diffusers should have extended panels if the selected diffuser dimensions are smaller than the grid. The use of perforated-face ceiling diffusers is restricted to constant volume cooling only applications.

SECTION 23 30 00 - AIR DISTRIBUTION

6. The use of lined ductwork for supply applications is prohibited. For sound attenuation, short runs of return duct may be lined.
7. Sidewall registers are not to be used for variable volume applications.
8. Unless required by restrictive codes, air filtration media shall be of the bag type or FARR 30/30 pleated throwaway; roll filters are not to be used.
9. Duct-access doors shall have sealing gaskets and hinged doors with twist-lock latches.
10. All Fire Dampers are to be dynamic-rated dampers constructed of steel with rust-resistant finish and with seams sealed and tested at the factory. Maximum pressure drop for installed fire dampers: 0.1 w.c. at 1500 FPM.
11. Dynamic rated Type “A” curtain-type fire dampers located directly behind sidewall grilles and registers or where specifically noted.
12. Dynamic rated Type “C” curtain-type dampers in walls and floors in the following locations:
 - Duct systems operating with velocities below 2,000 FPM
 - Duct size complying with the UL-listing limits regarding damper size and orientation
 - Duct systems operating below 4” w.c.
13. Multi-blade fire dampers in walls and floors in the following locations:
 - Duct systems operating with velocities at or above 2,000 FPM
 - Duct size complying with the UL-listing limits regarding damper size and orientation
 - Duct systems operating at or above 4” w.c.

Part 3 Execution

1. All supply, return and outside air ductwork with square elbows shall have turning vanes.
2. Branch-to-main air quantity ratios greater than 30 percent require splitter-damper fittings with locking control rods; this applies equally to return air ductwork.
3. Where more than one supply outlet is served by a branch-to-main take-off, volume extractors with locking control rods shall be installed.
4. Placement of air handling units shall require adequate space for normal fan and filter maintenance, SMACNA-approved duct connection arrangements, and coil removal space. Minimum spacing at access door on each side of the coil for cleaning and control access.
5. Temperature control dampers are not to be used for balancing outdoor/return air ratios.
6. Duct-mounted fire dampers, coils, control elements, or other devices requiring periodic maintenance shall be accessible through fabricated or manufactured duct-access doors. In the case of fire dampers and coils, doors are to locate upstream and down-stream of the device.
7. Flex duct run-outs to diffusers or grilles shall not exceed 4 feet in length.

SECTION 23 30 00 - AIR DISTRIBUTION

8. Supply return and exhaust air outlets and transverse readings must be balanced to within 10% of the design quantities.
9. The airflow testing and balance agency must be a certified member of the Associated Air Balance Council or National Environmental Balancing Bureau and employed by the general contractor or by Vanderbilt, rather than by the mechanical contractor.
10. Water flow balancing shall also be performed by the testing and balance agency.

END OF SECTION -

SECTION 23 36 00 - AIR DISTRIBUTION SYSTEMS**Part 1 General****1.01 Scope**

Terminal units are defined to include those HVAC devices used to control space temperature. Variable air volume (VAV), constant volume (CV) and fan-powered (FP) terminal boxes etc. are examples.

Part 2 Products

2.1 Full shut-off terminals are restricted to interior spaces of buildings. Maximum/minimum air flow terminals with hydronic reheat or fan-powered terminals are acceptable throughout the structure. Terminal box casings shall be constructed of panels with insulation sandwiched between galvanized steel; internally insulated construction is permitted. Each terminal box shall have a multiple point, averaging flow sensor with taps for measuring within +/- 5% of unit cataloged airflow and discharge air temperature sensor. Where hydronic reheat coils are applied, the terminal box casing must have a removable, gasketed access panel upstream of the reheat coil for cleaning purposes.

2.2 All terminal boxes shall have discharge air temperature sensors.

2.3 The use of electric re-heat coils is forbidden without written approval by the Project Manager. Hot water reheat coils are preferred.

2.4 Terminal box re-heat coils must be selected for an entering water temperature of 100 Deg-F to account for heat exchanger outdoor reset in the summer; especially those serving spaces with no building exterior. Designers are cautioned to specify re-heat coil performance at 'full air flow' where minimum air flow is overridden by CO2 monitors or certain exhaust conditions.

2.04 Room and fan controls see Section 23 09 13 and Section 23 09 93.

Part 3 Execution**3.1 Terminal Reheat Boxes**

Terminal reheat boxes shall be installed so as to be easily serviceable. A minimum of 24 inches clear shall be maintained on the control side of the box. Greater clearances shall be maintained by code or manufacturer's recommendation if mandated.

3.2 Access Panels

Access panels must be installed upstream of each hot water reheat coil for future cleaning without removal of the terminal box.

SECTION 23 36 00 - AIR DISTRIBUTION SYSTEMS

1. Refer to Section 23 05 23 for valve specifications for any valves included in factory-installed or field-fabricated piping packages. Comply with the following fan-coil piping schematics:

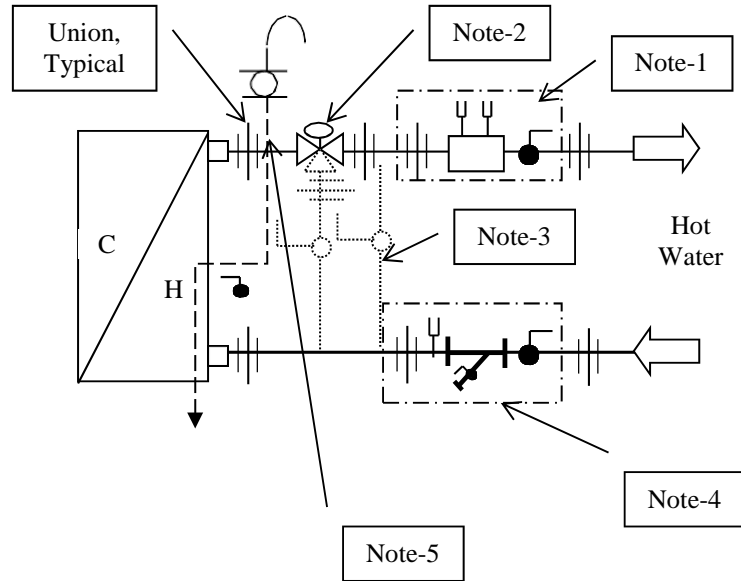

Terminal Box Casing

- Notes:
1. Combination 'auto-flow' assembly with balance valve, isolation ball valve, union, T&P test plugs at inlet and outlet. Balance valve to have threaded connections with a soldered adapter (typical).
 2. Two-way or three-way control valve as defined by the project control scheme (typical).
 3. Temporary flushing loop; with or without ball valve. After cleaning remove piping loop or close valve, if used, and remove handle.
 4. Combination ball valve, strainer with blow-down ball valve, union, and T&P test plug. Ball valve to have threaded connections with a soldered adapter (typical).
 5. 3/8-inch ball valve air vent.
 6. All piping, valves, fittings, drain pans, etc. shall be installed to allow access by maintenance personnel.

-END OF SECTION-

SECTION 23 64 00 - CHILLERS**Part 1 General****1.01 Scope**

1. Projects having projected air-conditioning loads that are constructed remotely from any of Vanderbilt's Central Chilled Water Plants, shall be designed with central water-cooled chillers. Air-conditioning systems of lesser capacity may have air or water-cooled scroll chillers.
2. At the present time, there are two major central water plants on Campus: one on the main campus in the VU Power House with satellite plants in Vaughn Hall and Kissam; the second is on the Peabody Campus located at the Maintenance Building with a satellite plant in the Mayborn Building. The main campus plant has limited capacity; the Peabody plant has a limited amount of available capacity with provisions for additional chillers. These central plants produce 45 Deg-F chilled water year around.
3. The necessary Engineering Load Studies shall be presented to the Project Manager for approval to connect projects into any of these plants.

Part 2 Products**1.01 Approved Manufactures**

1. Unitary chillers by Trane, Carrier, York, or McQuay will be given equal consideration based upon IPLV performance and cost. Where modular chillers are suitable, Multi-Stack or equal chillers may be used based on IPLV performance and cost.
2. All chillers are required to have ARI-550/590 factory performance tests.
3. Chillers may be of the steam turbine-driven centrifugal type where central steam is available to the project; otherwise, electrical centrifugals utilizing R134A or R123 refrigerant is required. Engineering operating cost studies shall be used to determine which chiller type or refrigerant is best.
4. Hermetic motors are preferred for electrical centrifugals; where external motors are used, room air-conditioning must be installed to off-set the motor heat rejected to the room. The engineering cost studies must include the penalty for cooling the room for open-drives.
5. Electrical centrifugal chillers shall have variable-speed drives. Inverter cabinet cooling for variable speed drives shall be cooled with chilled water; not condenser water.
6. Integral water-cooled heat exchangers for these drives must have cleanable strainers sufficiently sized to limit blow-down to once a week.

SECTION 23 64 00 - CHILLERS

Part 3 Execution

1. Install chillers at grade level for service. The location of chillers shall provide sufficient head room and floor space for maintenance, tube cleaning, and tube replacement.
2. Provide floor drains at each end of the chiller.
3. Connect each building in accordance with the following piping arrangement:

- F Ultrasonic Flow Meter
- T Thermometer
- S T & P Test Port
- * Temperature to BAS
- Spring-Loaded Check Valve

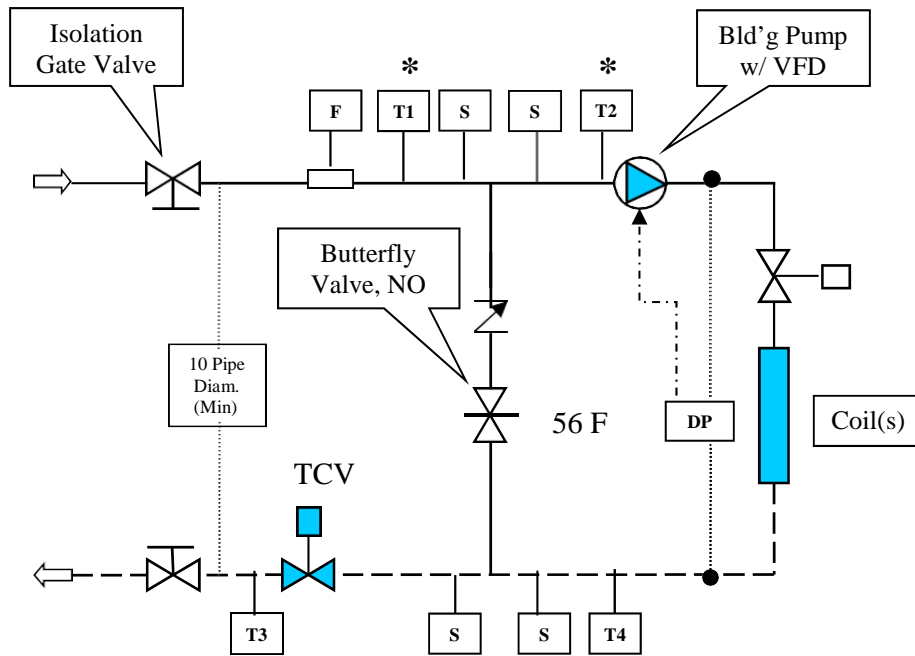

*

TYPICAL CHILLED WATER CONNECTION TO CENTRAL PLANT

SECTION 23 64 00 - CHILLERS

- At each building chilled water service entrance, install the following 'test manifold':

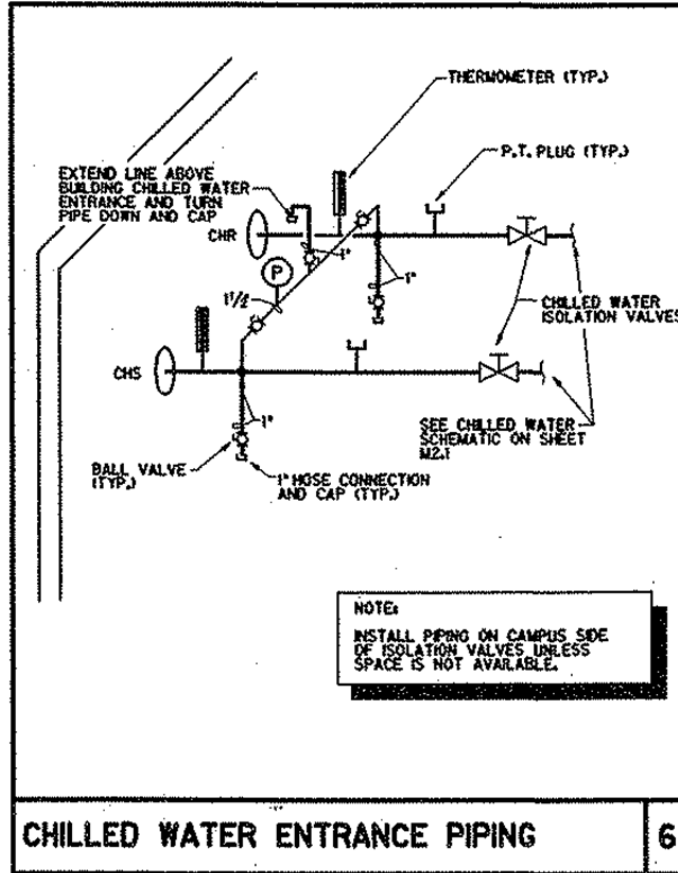

- END OF SECTION-

SECTION 23 65 14 - COOLING TOWERS**Part 1 General****1.01 Scope**

1. Select cooling tower fans to limit generated noise levels at full speed to a maximum of 65 db at 25 feet from the intakes and discharge.
2. Cooling towers shall be screened from view, use Peabody Chiller Plant cooling tower enclosure as an example.

Part 2 Products**2.1 Acceptable Manufacturers**

1. Marley
2. Baltimore Air Coil
3. Where applications permit the tower to be out of service for inspection and maintenance, induced draft, counter-flow, pressurized distribution towers with belt drives manufactured by Evapco or equal may be considered subject to approval by the VU Project Manager.

2.2 Tower Characteristics

1. Provide distribution basin covers for all cooling towers and stainless steel hot water and cold water basins.
2. Install screens on fan discharge grilles when there is a danger of leaves entering the tower when the fan is off.
3. Basin heaters are required; steam coil where available.
4. Railings and ladder personnel protections shall be OSHA compliant.
5. Permit access for routine maintenance and service while the unit is in operation.
6. Cooling tower shall be designed for return piping through the bottom of the tower when possible.

Part 3 Execution

1. All cooling towers shall have variable speed drives with 'hard-wired contactor' bypass in addition to the standard electronic bypass.

SECTION 23 65 14 - COOLING TOWERS

2. Each tower to have "quick-fill" connections in addition to normal "make-up".
3. Install a 1-1/2 inch hose bibb within 25 feet of all cooling tower basins.

- END OF SECTION-

SECTION 23 70 00 - CENTRAL STATION AIR HANDLING UNITS**Part 1 General****1.01 Scope**

1. The installation of central-station air distribution equipment manufactured in accordance with ARI 430 is preferred for delivery of heated, cooled, and humidified air to occupied spaces. By approval of the Project Manager packaged heating and cooling equipment are only permitted where campus steam or chilled water distribution systems are unavailable or where small-scale projects warrant their use.
2. In addition to the performance requirements for air delivery, cooling, heating, and humidification, sound power levels shall be specified.
3. Air handling unit shall be designed for a 40-year useful life.
4. Air intake shall be at least ten feet above finish grade.
5. In new buildings future air handling unit replacement can be accomplished with unit assembled in place. Openings larger than 6' x 6' are not required unless the largest AHU component requires a larger opening.

Part 2 Products**1.1 Acceptable Manufacturers**

- a. Huntair, Ingenia, ClimateCraft, Governair, Temtrol, Energy Labs, Trane Custom, York Custom

1.2 Casings

Casings shall be constructed of 3" thick top and side composite panels made with minimum R20 foam insulation injected between hot dipped galvanized steel sheets. The panels shall be supported by insulated heavy gauge channel posts and shall meet L/200 maximum deflection under positive and negative testing pressures. Minimum 18 gauge thickness. Appropriate doors for service and access to internal components shall be similarly constructed and flush-mounted with heavy duty door hinges, gaskets, and heavy duty latches. Doors for sections under negative pressure will swing outward; for positive pressures, door swing will be inward. Each section containing access doors shall have LED light fixtures with switches externally mounted to the casing. Floor plates shall be constructed with 3/16" thick aluminum tread plate with welded seams. . Drain pans for cooling coil condensate shall be constructed of minimum 16 ga stainless steel. Base floor and drain pans shall be insulated with minimum R20 injected foam insulation. The insulation for the entire unit shall be configured so there are no conduction paths that shortcut the insulation effectiveness. Base rails shall be constructed from welded structural steel members as described by the AISC, and shall be designed to provide support for the unit and allow for proper condensate drainage. A combination of base rail height and housekeeping concrete pad height are necessary to provide the correct condensate and steam trap heights found in the EXECUTION portion of this section.

SECTION 23 70 00 - CENTRAL STATION AIR HANDLING UNITS**1.1 Fans**

Fans shall be Class 3, AMCA rated with backward inclined blades. The fan and housing shall be manufactured such that the fan wheel and/or bearings can be replaced without disassembly of the fan housing or the air-handling unit casing. Use direct drive fans. Use a fan wall arrangement when the airflow is above 3,554 cfm. Provide pressure taps in the fan inlet cone to facilitate airflow measurement. Fans shall be selected to avoid surge conditions; maximum fan RPM must be below the first critical fan speed. Fans and the fan motor shall be internally mounted on a steel base isolated from the casing floor. Fan motors shall comply with Section 23 05 00.

1.2 Filter sections

1. Viledon T-60 pocket minimum MERV 10 filter sections or equal shall accommodate filter media and be front loading with spring retention. If unavailable, as a minimum provide UL 900, Class I or II, 2-inch, pleated MERV 8 disposable filter media with microbial resistant coating.
2. Units shall be designed to equip all pocket filters in vertical orientation.
3. Instrumentation includes a Magnehelic differential pressure gauge to indicate filter loading and a dial or digital thermometer whose size and scale to permit viewing leaving air temperature.

1.3 Coils

Coils shall be UL-labeled with ARI 410 certification labels and comply with Section 23 82 16. Chilled water coils must have stainless steel supports.

All coils shall have 1/2" drain and vent with ball valve and 3/4" hose connection.

1.4 Humidifiers

Where humidifiers are required comply with Section 23 84 00. Humidifiers should be installed downstream of a heating coil but never installed upstream of a cooling coil.

Part 3 Execution

1. Fan-walls shall be equipped with one variable frequency drive per fan. The fan airflow shall be accumulated with a Paragon FAATS-1000 fan array totalizing system, reporting to the building control system via BACnet protocol.
2. Units shall incorporate UV lights with minimum URV 10 rating and associated BACnet compatible radiometer set to alarm for maintenance when UV lights reaches less than 80% of installed capacity.
3. Unless approved by the Project Manager, central station air handling equipment must be installed indoors on floors. Provide an appropriate floor drain near-by for condensate drainage; "thru-wall to grade" condensate drains are not permitted. Position the equipment to allow service access, coil removal, and adequate clearance for piping, ductwork, etc. Particular attention must be given to the location of units and their respective

SECTION 23 70 00 - CENTRAL STATION AIR HANDLING UNITS

outside air intakes to assure mixing of return air and outside air to avoid coil freezing or nuisance fan outages. See section 23 30 00 for further coil freeze protection scheme requirements.

4. All installations requires an auxiliary drain pan completely underneath the unit with a drain.
5. Rooftop installations are discouraged. When used; matching roof curbs shall totally enclose all piping and conduit to the unit. To minimize sound transmission from this equipment to the building, install rail isolators and maintain the roof deck continuity underneath the unit with holes for only the duct, piping, and conduit.
6. Temperature-activated Economizer packages for "free cooling" shall be provided for all central station air handling equipment, unless approved otherwise by Project Manager.
7. Piping arrangements shall have sufficient unions or flanges to allow coil removal without cutting piping.
8. High air intake facilitated by units in the attic is preferred. Rooftop units are not acceptable – unit shall have penthouse or upper level MER.
9. All traps shall be a minimum of 18” below heat transfer equipment being serviced. All cooling coils shall have condensate drains with a trap as follows:

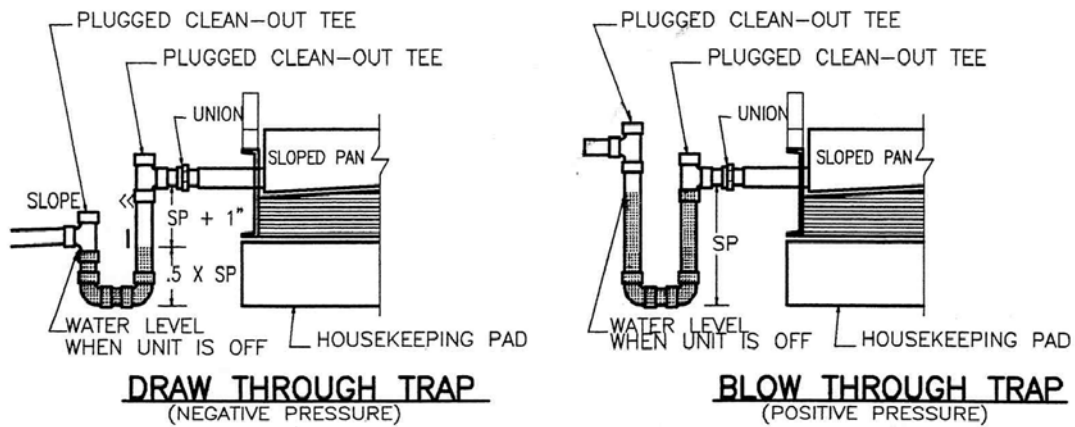

CONDENSATE DRAIN PIPING OPTIONS

NO SCALE

-END OF SECTION-

SECTION 23 73 00 - PACKAGED HEATING AND COOLING UNITS**Part 1 General****1.01 Scope**

The installation of commercially packaged cooling and heating equipment is permitted by approval of the Project Manager only where campus steam or chilled water distribution systems are un- available or where small-scale projects warrant their use.

Part 2 Products**2.1 Packaged Equipment**

Packaged equipment shall be UL-labeled with ARI refrigeration labels; where gas heaters are included, AGA ratings are required. All packaged equipment shall have BACnet compliant controls for interface into Building Automation System (BAS). Provide vendor network control system with single point BACnet interface into BAS. All points visible in the packaged unit's networked system shall be visible in BAS. Coordinate with BAS vendor prior to bid and include all hardware, software and wiring necessary for a complete and coordinated interface to BAS. The BACnet communication will include the status, mode of operation (heating, cooling or alarm) and supply temperature from each of the packaged units to the BAS.

2.2 Cooling evaporator

Cooling evaporator and condenser coils shall have copper tubes and aluminum or copper fins; spine or brush type coils are not permitted.

2.3 Compressors

Compressors shall have crankcase heaters.

2.03 Economizer packages

1. Temperature-activated economizer packages for "free cooling" shall be provided for all packaged cooling equipment, unless approved otherwise by Project Manager.

Part 3 Execution

1. Where packaged heating and cooling equipment is installed on floors, provide an appropriate floor drain near-by for condensate drainage. "Thru-wall to grade" condensate drains are not permitted.
2. Ceiling installation requires an auxiliary drain pan completely underneath the unit with a drain.
3. Rooftop installations are discouraged; when used, matching roof curbs shall totally enclose all piping and conduit to the unit. To minimize sound transmission from this equipment to the building, the roof deck shall be continuous underneath the unit with holes for only the duct, piping, and conduit.

SECTION 23 73 00 - PACKAGED HEATING AND COOLING UNITS

- All traps shall be a minimum of 18" below heat transfer equipment being serviced. All cooling coils shall have condensate drains with a trap as follows:

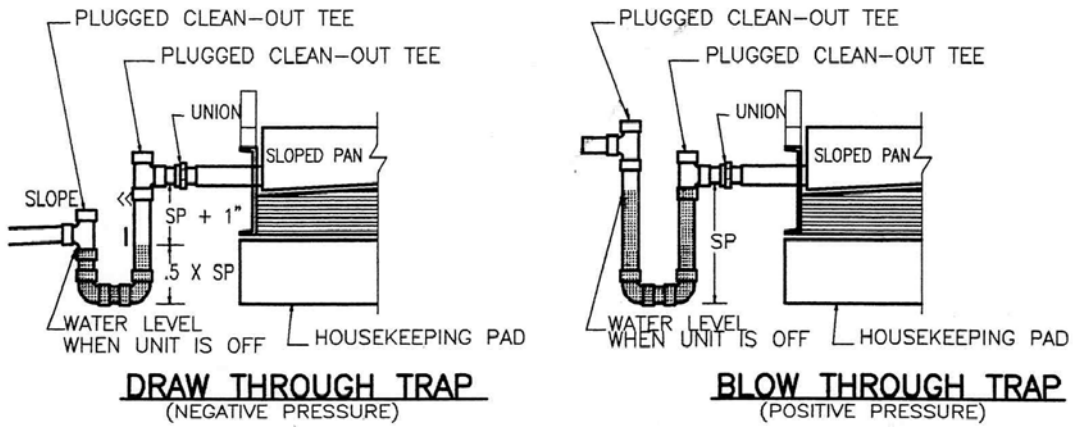

CONDENSATE DRAIN PIPING OPTIONS

NO SCALE

-END OF SECTION-

SECTION 23 80 00 - CENTRAL HEATING AND COOLING DISTRIBUTION SYSTEMS**Part 1 General**1.01 Scope

1. Buildings shall be connected to the University Steam Distribution System unless approved otherwise by the Project Manager. Space heating shall be accomplished with steam-to-water heat exchangers. The use of steam for space heating is limited to unit heaters or preheat coils.
2. The transfer of heat from points of generation to coils or terminal units within the building require Water or Steam piping systems. For design purposes, assume the steam conditions entering a facility are 125 PSIG and 425 Deg-F.

Part 2 Products

1. No rubber flexible connectors shall be allowed on hydronic systems. Connectors shall be stainless bellow-type with braided steel outer covering.
2. All expansion joints for steam and condensate shall be of the telescoping variety similar to Hyspan series 6500.

Part 3 Execution

1. Provide Floor Drains near the piping drain points. Each valve, coil, or terminal shall have Isolation Valves with Unions or Flanged Connections for normal maintenance and repair.
2. Each building connected to the University Steam Distribution System shall have Pressure Reducing Stations (PRS) installed to satisfy heat exchanger, chiller, water heater, or other terminal equipment design inlet pressures. System design should be 125 PSIG and 425 Deg-F. Pressure Reducing Stations shall have dual valves with a manual globe valve bypass. One sized for 1/3 of the total building steam load; the other for 2/3. Pressure gauges shall be installed upstream and downstream of each PRS.
3. Water and steam piping shall be installed so that the systems can be drained. Minimum ½ inch manual Vents are to be located at all high points with minimum ½ inch Manual Drains with hose fitting at each low point.
4. ASME pressure relief valves shall be installed downstream of all PRS, on the leaving side of all water-to-air heat exchangers, and on the discharge of chilled water primary and condenser pumps. The discharge of each relief valve shall terminate outside the building.

SECTION 23 80 00 - PACKAGED HEATING AND COOLING UNITS

5. Steam piping systems shall be designed and installed for condensate and steam flow in the same direction. Steam control valves and steam pressure reducing valves and condensate traps shall have a valved bypass and upstream strainer for maintenance and removal without shutting down the system.

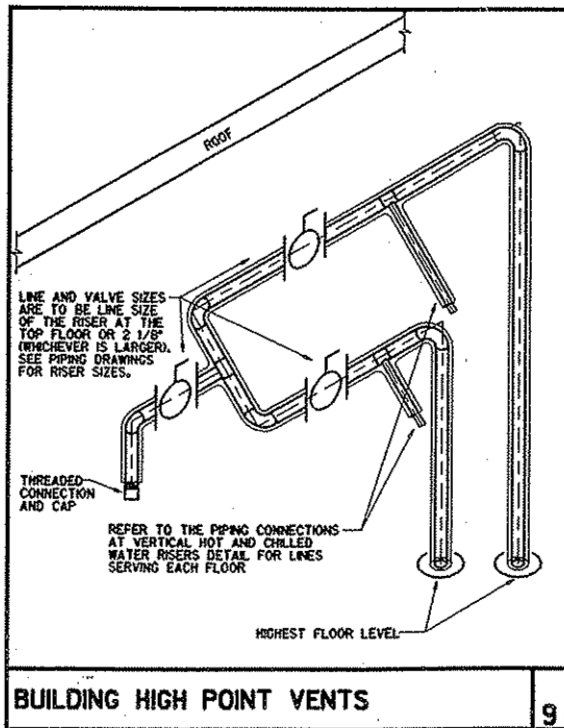

6. The contract drawings shall indicate all trap locations and their capacity in LB/HR. Traps shall be selected with a factor of safety of 2.
7. Thermal expansion provisions including expansion devices, loops, guides, and anchors must be dimensioned and detailed on the drawings. Submit thermal expansion calculations to the Project Manager prior to completion of the contract documents.
8. All heat transfer piping systems shall be identified whether exposed or concealed; all valves are to be tagged and identified with by a valve schedule appropriately inside mechanical rooms.
9. Refer to Section 23 05 00 for cleaning procedures for hot, chilled water, steam, and condensate piping.

- END OF SECTION-

SECTION 23 81 00 - DUCTLESS SPLITS

PART 1 - GENERAL

1.1 SCOPE OF WORK

1. Variable refrigerant flow (VRF) heating and cooling systems, sometimes known as ‘ductless systems’ are relatively new to the Nashville area and Vanderbilt Campus in particular. Older, historical facilities on Campus lend themselves to this new method of building environmental control. Currently, the engineering community relies upon manufacturers for design. As such, the design engineer may choose one of two approaches to the contract document content.
2. One approach would include a general layout showing the type and capacity of indoor units respective of proper thermostatic control zoning and the location, size, and capacity of the condensing units with requirements that each manufacturer complies with the requirements of paragraph 1.03 herein. As an alternate approach, the contract documents may be produced with a specific manufacturer’s product as a basis of design (BOD).
3. Where variable refrigerant flow (VRF) heating and cooling systems are employed, heat recovery systems are preferred and condensing units should be water-cooled using central chilled water. Where central chilled water is unavailable, air-cooled condensing units may be used if approved by the VU project manager. Design water cooled systems with variable temperature condenser water that can be heated to 70F during winter design conditions.
4. Provide VRF controls which are BACnet compliant for interface into Building Automation System (BAS). Provide vendor network control system with single point BACnet interface into BAS. All points visible in VRF vendor’s networked system shall be visible in BAS. Coordinate with BAS vendor prior to bid and include all hardware, software and wiring necessary for complete coordination interface to BAS. The BACnet communication will include the status, mode of operation (heating, cooling or alarm) and supply temperature from each of the VRF units to the BAS. All data shall be provided in SAE units.

1.2 INSTALLATION REQUIREMENTS

1. The system must be installed and certified by a factory trained contractor/dealer. The sub-contractor bidders shall be required to submit training certification proof with bid documents.

1.3 EQUIPMENT SUPPLIER REQUIREMENTS

1. Regardless of the design basis, all acceptable manufacturers, including the BOD manufacturer, shall submit a separate bid along with the following drawing package submitted in ‘.dxf’ digital format or equivalent on a CD or DVD and one set of 30”x42” prints for approval by the design engineer and Owner:

SECTION 23 81 00 - DUCTLESS SPLITS

- Equipment schedule with model numbers, capacities, power requirements, physical dimensions, etc.
 - Refrigerant piping layout and schematics with pipe sizes
 - Refrigerant piping rise and fall limitations and provisions for thermal expansion
 - Locations and details of refrigerant piping design
 - Detailed provisions for thermal expansion and stress relief at branch selectors and indoor units
 - Power and control wiring schematics
 - Thermostat location, type, and features
 - Control logic narrative
2. In addition to the aforementioned drawing package submittal at bidding, submit the following:
- Typical submittal literature or data sheets, for each piece of equipment and thermostats
 - Installation manuals
 - Installer certification classroom curricula

1.4 SUBMITTALS

1. Submit complete product data, system layout, pipe routing and sizing for review and approval by Engineer and VUCP. Include capacities, electrical data, dimensions, and controls.

1.5 QUALITY ASSURANCE

1. The units shall be AHRI Standard 1230 Certified and listed by Electrical Laboratories (ETL) and bear the ETL label.

1.6 WARRANTY

1. The units shall have a manufacturer's warranty for a period of one (1) year from date of installation. The units shall have a limited labor warranty for a period of one (1) year from date of installation. The compressors shall have a labor and materials warranty of six (6) years from date of installation. During the stated period, should any part fail due to defects in material and workmanship, it shall be repaired or replaced by the manufacturer. All warranty service work shall be performed by a manufacturer's factory-trained service professional.

PART 2 - PRODUCTS**2.1 ACCEPTABLE MANUFACTURERS**

Daikin
LG
Mitsubishi

Prior to bid, final selection for major projects to be based upon mock up evaluations.

SECTION 23 81 00 - DUCTLESS SPLITS**2.2 SYSTEM DESCRIPTION**

1. A variable capacity, heat recovery/heat pump air conditioning variable refrigerant volume type split system. The system shall consist of multiple evaporators using PID control, connected to a single condenser unit or multiple condenser units with branch selector refrigerant distributor boxes.
2. For heat recovery systems, operation of the system shall permit either individual cooling or heating of each fan coil simultaneously or all of the fan coil units associated with one branch cool/heat selector box. Each fan coil or group of fan coils shall be able to provide set temperature independently via a local remote controller or a BAS interface.

2.4 CONDENSING UNITS

1. The condensing unit shall be factory assembled and pre-wired with all necessary electronic and refrigerant controls. The refrigeration circuit of the condensing unit shall consist of scroll compressors, motors, electronic expansion valves, solenoid valves, 4-way valve, distribution headers, capillaries, filters, shut off valves, oil separators, service ports and liquid receivers.
2. Compressor controls for 'twinned' condensing units shall have the ability to share load at less than 100% load to equate run-times.
3. The connection ratio of indoor units to condensing unit (or diversity) shall be specified by the design engineer but no more than 130%.
4. The system will automatically restart operation after a power failure and will not cause any settings to be lost.
5. The following safety devices shall be included on the condensing unit: high pressure switch, control circuit fuses, crankcase heaters, fusible plug, high pressure switch, overload relay, inverter overload protector, thermal protectors for compressor and fan motors, over-current protection for the inverter and anti-recycling timers.
6. To ensure the liquid refrigerant does not flash when supplying to the various fan coil units, the circuit shall be provided with a sub-cooling feature.
7. Oil separators shall be standard with the equipment together with an intelligent oil management system.
8. Fan nominal sound pressure levels shall not exceed 56 dB(A).
9. The condenser heat exchanger shall be a stainless brazed plate type designed for closed loop/dry cooler applications with a maximum system water pressure of 285 psi for water cooled equipment.
10. The inverter drives shall provide for a low torque start with a capacity control range shall be 23% to 100%.

SECTION 23 81 00 - DUCTLESS SPLITS

11. The control voltage between the indoor and outdoor unit shall be two-wire multiplex transmission system low voltage DC shielded, stranded 2 conductor cable.

2.5 REFRIGERANT PIPING

1. Main lines shall be level or plumb as appropriate within ¼", and flaring of hard copper is not permitted.
2. Require application of labeling for refrigerant piping to trace each line set from each indoor unit to its branch selector and from each branch selector to its condensing unit.
3. All elbows shall be of the long radius type having a minimum bend radius of _____ pipe diameters. (*Engineer to fill in the blank*).
4. All brazing shall be done with inert gas purge. Brazing rods must not contain flux and have 15% silver as a minimum.
5. Prior to installation of refrigerant piping, the contractor shall submit samples of brazed copper joints for destructive testing by an independent lab; testing results must then be approved by the Owner and the engineer
6. The installing contractor must be certified by the manufacturer and must follow all sizing, routing, and installation recommendations.
7. Insulate all refrigerant piping with 1" thick elastomeric insulation. Insulation seams shall be on the bottom of all piping.
8. Install refrigerant-grade ball valves with Schrader ports and flared connections through 5/8" on suction and liquid lines leaving branch selector boxes to each indoor unit.

2.6 BRANCH SELECTOR BOXES

1. The selector boxes shall contain be factory assembled, wired, and piped and factory run- tested and have flare-type refrigerant control valves, sound absorption thermal material, powered by single phase power and DC control voltage less than 24 volts.

2.7 VRF INDOOR UNITS

1. The units shall be powered by single phase power and DC control voltage less than 24 volts and have factory wiring, piping, electronic proportional expansion valve, control circuit board, fan motor thermal protector, flare connections, condensate drain pan, condensate drain pump, self-diagnostics, auto-restart function, safeties, return air temperature sensor.
2. The cabinet shall be constructed with sound absorbing foamed polystyrene and polyethylene insulation with:
 - Optional high efficiency air filters.
 - Statically and dynamically balanced fan with high and low fan speeds and thermally protected

SECTION 23 81 00 - DUCTLESS SPLITS

- Condensate pan with a built in safety alarm and 'field supplied' secondary float switch to stop refrigerant flow.
3. The unit shall be compatible with interfacing with connection to BACnet for interfacing with connection to BAS system. Consult with vendor prior to applying controls.
 4. Wall-mounted thermostats with locking covers for offices, resident rooms, conference rooms, and other private spaces. In public areas where personal control of room temperature is unnecessary, remote wall-mounted sensors shall be used.

PART 3 - EXECUTION**3.1 INSTALLATION**

1. Install indoor air units, condensing units, and branch selectors in accordance with manufacturer's recommendations and as required for adequate service and maintenance clearances. Piping installation plan must be reviewed and approved by Vanderbilt staff engineers.
2. Where condensate pumps are required for all exposed indoor units, the pumps must be concealed from view. Check valves should be installed in condensate pump discharges where common gravity drain piping is subject to blockage. Treat the gravity condensate drain piping as though it were a sanitary drain with cleanouts at each change of direction, necessary intervals in long runs, and at the point of indoor terminal unit condensate discharge connections.
3. Control wiring, including wiring from the wall thermostats must be in conduit.
4. Pipe and hanger supports methods must be suitable for refrigerant piping necessary to accommodate pipe expansion while maintaining continuous insulation through the hanger or clamp.

3.2 FIELD QUALITY CONTROL

1. To insure proper installation, the manufacturer's agent shall visit the site in the company of the installing contractor and Owner during the construction period and submit field reports to the construction manager and the Owner of his observations and installer instructions.
2. Operation of the VRF system during drywall, casework, trim, painting, or other airborne contaminate production process is strictly forbidden.
3. After installation the manufacturer shall verify completion and correctness of startup procedures, supervise final refrigerant charging, and certify the system.
4. The design engineer must revise standard HVAC Testing, Adjusting, and Balancing (TAB) procedures commensurate with the VRF systems.

SECTION 23 81 00 - DUCTLESS SPLITS

3.4 CLEANING

1. On completion of installation, internally clean system according to manufacturer's written instructions. Remove foreign material and construction debris.
2. After completing system installations, including outlet fitting and devices, inspect exposed finish. Remove burrs, dirt, and construction debris and repair damaged finishes.

3.5 TRAINING

2. Provide one day of training for Owner's designated maintenance personnel on system installation basics and prior to construction and four hours of training for operation and maintenance after certification.

- END OF SECTION -

SECTION 23 82 00 - FAN COIL UNITS**Part 1 General**

Fan coil units are most often installed in housing units. Preferably, they should be of the horizontal type located above the room entry. Occasionally, FCU's are located on the exterior walls and are of the vertical console type.

Part 2 Products**2.1 Acceptable Manufacturers**

1. ENVIRO-TEC
2. International Environmental
3. Johnson Controls
4. Trane

Prior to bid, final selection for major projects to be based upon mock up evaluations.

2.2 Features

1. The essential components of all fan coil units include:
 - Casing width and depth sized to accommodate piping packages, including control valves; especially, electronic actuators.
 - Secure latches for casing removal in dormitories. Horizontal unit access cover latches prove to be unreliable when used for filter maintenance; submit details of the latching mechanism to the Owner for approval.
 - Foil-faced insulation on casings and bulk-heads.
 - Coil drain and auxiliary drain pans with internal closed-cell insulation and sloped for positive drainage.
 - Discharge air temperature sensor.
 - Auxiliary drain pans shall have an obvious drain or a water sensor connected to the controls system.
 - Field-fabricated piping packages and factory, pre-piped packages as follows:
 - Unions for coil and control valve removal without cutting piping.
 - Screwed ball valves and control valves with copper adapters
 - Strainers at control valve inlets with blow-down valve.
 - Piping vents discharging into the auxiliary drain pan.
 - Automatic flow control devices, if space allows
 - Means of measuring water flow.
 - Published gauge thickness for all metal materials.
 - FCU motors to have Electronically Commutated Motors (ECM) unless approved otherwise by the VU Project Manager.
 - See Section 23 09 13 for room and fan controls.

SECTION 23 82 00 - FAN COIL UNITS

2. Heating Coils must be selected for an entering water temperature of 100 Deg-F to account for heat exchanger outdoor reset in the summer; especially those serving spaces with no building exterior.

Part 3 Execution

1. Field-fabricated piping packages are preferred for fan coil units; only in certain applications are factory piping packages allowed.
2. Piping packages for vertical fan coil units must be totally contained within the unit. Horizontal units must contain the chilled water piping package but may have hot water valve packages outside the unit provided a 'field-installed' drain pan is installed beneath the assembly. Subject to the Owner's approval, combination integrated ball valve/strainer with union and pressure/temperature readout port on the supply piping and an integrated manual balancing valve pressure/temperature readout port on the return piping for terminal units provided sufficient installation and service access is available. All pipe connections shall be threaded with unions for disassembly. Assemblies shall be equivalent to those manufactured by HCI in Madison, Wisconsin. All piping, fittings, valves or unions subject to sweating shall be located above drain pans.
3. Refer to Section 23 05 23 for valve specifications for any valves included in factory-installed or field-fabricated piping packages.

SECTION 23 82 00 - FAN COIL UNITS

4. Comply with the following fan-coil piping schematics:

5. FCU Casing

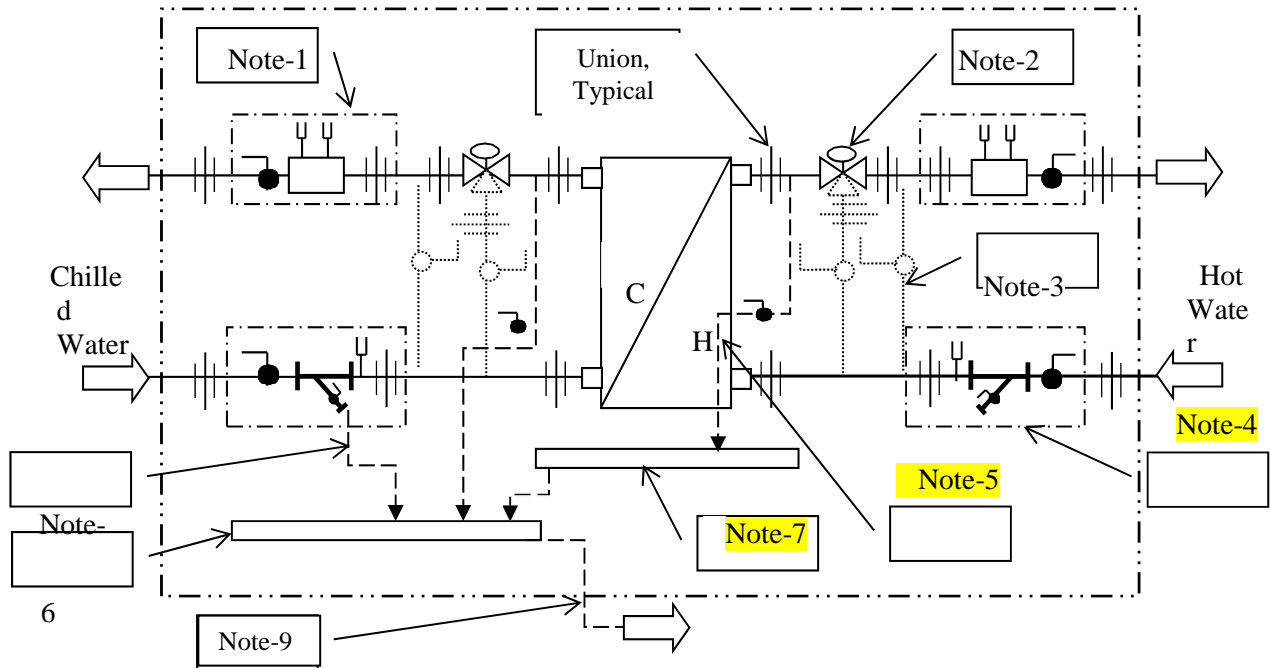

Notes:

1. Combination 'auto-flow' assembly with balance valve, isolation ball valve, union, T&P test plugs at inlet and outlet. Balance valve to have threaded connections with a soldered adapter (typical).
2. Two-way or three-way control valve as defined by the project control scheme (typical).
3. Temporary flushing loop; with or without ball valve. After cleaning remove piping loop or close valve, if used, and remove handle.
4. Combination ball valve, strainer with blow-down ball valve, union, and T&P test plug. Ball valve to have threaded connections with a soldered adapter (typical).
5. 3/8-inch ball valve air vent discharged to drain pan (typical).
6. Strainer blow-down discharged to drain pan (typical).
7. Insulated coil drain pan.
8. Insulated auxiliary drain pan. (Note: On horizontal units, located outside the FCU casing).
9. Condensate drain piped to open-site drain.
10. All un-insulated chilled-water piping, fittings, valves, etc must be located above the insulated auxiliary drain pan.
11. All piping, valves, fittings, drain pans, etc. shall be installed to allow access by maintenance personnel.

-END OF SECTION-

SECTION 23 82 16 - COILS

Part 1 General

1.01 Scope

1. Where steam or hydronic coils are installed, they shall be protected from freezing. Freeze protection schemes for coils with design Entering Air Temperatures (EAT) above 40 Deg-F will include freeze stats which interrupt airflow at EAT's below 40 Deg-F. To further protect the coils, return air and outside air ductwork upstream of the coils shall be designed for adequate mixing of the air before entering the coil. Should physical restraints make this impractical, manufactured devices for blending the air streams shall be installed. The ductwork and coil arrangements must consider the effects of "stratified air" and eliminate potential nuisance freeze stat trip-outs and coil freeze-up when air is not flowing. If, in the opinion of the Project Manager, these safeguards are absent, coils for mixed-air applications shall be of the integral face and bypass type.
2. Makeup air units delivering 100% outdoor with hydronic, non-face and bypass, heating coils must employ a non-freezing scheme. If an inline circulating pump for the coil freeze protection scheme ensure it is decoupled and does not affect the building heating hot water flow. Under unusual freezing potential, downstream cooling coil control valves should open for full flow.
3. Preferably steam or hydronic coils subject to design EAT's less than 45 Deg-F should be of the "integral face and by-pass type".
4. The use of electric duct coils is discouraged. When approved by the Project Manager, they may be utilized where central steam and/or hot water are unavailable.

Part 2 Products

2.01 Acceptable Manufacturers

1. Manufactured air mixing devices shall be Air Blender or equivalent.
2. Integral face and bypass coils shall be manufactured by Wing or equal.
3. Only if their use is approved by the VU Project Manager, electric coils shall be of the open coil type provided they are installed no closer than 5 feet upstream or downstream of duct fittings, transitions, or take-offs; and have a face velocity greater than 500 FPM. Where velocities are less or installation requirements violate the "5 foot" limit, sheathed coils shall be used. All electric duct heaters shall have automatic reset, insulated control box, adjustable differential pressure switch, and integral door disconnect.
4. Steam and hydronic coils shall have copper tubes.
5. Coils shall not have ferrous and non-ferrous metals in contact with one another. Coils with copper tubes and cast iron headers or copper tubes with copper headers and a steel service connection are not acceptable.

SECTION 23 82 16 - COILS

6. Air-handling units with multiple coil sections shall be constructed so as to allow removal of one coil with the remainder staying in place.
7. Hydronic cooling coils shall be selected for a minimum entering chilled water temperature of 45 Deg-F.
8. All cooling coils, except those installed in room terminal units, shall have drain pans constructed of stainless steel.

Part 3 Execution

1. No freeze stat shall be installed closer than 20 feet from an outside wall unless approved by the Project Manager.
2. Integral face and bypass damper control sensors must be located a minimum of 3 feet downstream of the coil. When located upstream of cooling coils, the cooling coil capacity shall include heat contributed by the face and bypass coil; for Wing coils this is approximately a 5- degree rise even with the bypass fully open.
3. Steam coils shall be trapped, have a vacuum breaker, and be drainable.
4. Hydronic coils shall be drainable and manually vented.
5. Under no circumstances are open-coil type, electric-duct heaters permitted for Variable AirFlow applications.
6. All cooling coils shall have condensate drains with a trap as detailed in Section 23 70 00. The traps shall discharge into a floor drain.

- END OF SECTION-

SECTION 23 84 00 - HUMIDITY CONTROL**Part 1 General**

1.01 Scope

1. Control of space humidity is required. Attaining acceptable indoor air quality includes establishing and implementing a moisture control strategy for controlling moisture flows and condensation to prevent building damage and mold contamination. Contractor shall provide PM with a recommended strategy that complies with Ashrae 55-2010 standards on indoor environmental quality and moisture control, particularly as it pertains to computer rooms, libraries, medical facilities, research facilities, and other specific areas defined by the Project Manager. Where a humidifier is required, the Architect shall design the building envelope to prevent condensation harmful to the structure.
2. Where humidity control is needed, refrigeration is required to control the upper limits of humidity levels during the summer and humidifiers are required for winter operation to maintain the minimum levels.
3. The use of sprayed coils for humidity control is prohibited.
4. Steam-fired humidifiers are to be used where steam is available; otherwise the electronic or infra-red type are acceptable.

Part 2 Products

Humidifiers of the Steam type shall have double tubes with steam jacketed separating chamber, modulating control valve, steam strainer, inverted bucket steam trap, and temperature switch.

Part 3 Execution

1. When steam-fired duct humidifiers are installed, provide sufficient clearance from duct fittings, transitions, etc. to preclude condensation; provide moisture sensors to shut off the steam flow should condensation be encountered. Interlock steam control valves with air flow to prevent steaming with loss of air movement. Designers are cautioned that smoke detectors installed downstream of air handling units often detect humidifier discharge as smoke and create nuisance AHU outages.
2. Electronic and infra-red humidifiers shall be installed with provisions for periodic draining and have automatic flush cycles to prohibit non-condensable build-up.
3. All duct-mounted humidifiers shall have auxiliary drain pans installed underneath with outlets piped indirectly to a floor drain.
4. Drains from drain pans on AHU's.

- END OF SECTION -

SECTION 26 00 00 - BASIC MATERIALS AND METHODS

Part 1 – General

1.1 Power and Communication Utility Poles

Aerial utilities and utility poles are not acceptable. Special circumstances must be approved in writing by Campus Planning & Construction.

1.2 Underground Power Transmission and Distribution Lines

Underground power lines must be encased in concrete.

1.3 Underground Communication Lines

Fiber-Optic underground communication lines shall be installed with a metallic wire detectable by underground location equipment.

1.4 Campus Electrical Base Maps

Some drawings showing the location of existing lines for these networks may be found at the Space & Facility Information Center, 322-2715, Room 106A, Bryan Building. Arrange through the Project Manager to review what coverage is available. Costs of printing arranged through Campus Planning will be chargeable.

Part 2 – Products

Part 3 – Execution

Utilize dry type transformers or an FM Approved transformer with FM Approved less flammable fluid. If not a FM Approved transformer or mineral oil/not FM Approved fluid must be used, then relocate the transformer away from the building walls in accordance with FM Global Property Loss Prevention Data Sheet 5-4, *Transformers*, Table 5 (reprinted below). Please submit additional details regarding the type and location of the transformers to FM Global for review.

Table 5. Separation for Exposure Protection of Main Building Walls (also refer to Figure 2b)

Fluid or Transformer Type	Fluid Volume, gal (m ³)	Minimum Horizontal Distance from Containment to Exposed Building Wall (Dimension X in Figure 2b)		
		2-hour fire-rated wall, ft (m)	Non-combustible wall, ¹ ft (m)	Combustible Wall, ¹ ft (m)
FM Approved transformer or equivalent	per Approval listing	3 (0.9)		
FM Approved Liquid in non-Approved transformer	≤10,000 (38)	5 (1.5)		25 (7.6)
	>10,000 (38)	15 (4.6)		50 (15.2)
Non-Approved transformer liquid	<500 (1.9)	5 (1.5)	15 (4.6)	25 (7.6)
	≤5,000(1.9-19)	15 (4.6)	25 (7.6)	50 (15.2)
	>5,000 (19)	25 (7.6)	50 (15.2)	100 (30.5)

¹ For definitions of combustible and noncombustible construction materials, see Appendix A of DS 1-1, *Firesafe Building Construction and Materials*.

Emergency generators and their associated fuel supplies should be located outside of important buildings

where practical and they should be installed and protected in accordance with FM Global Loss Prevention Data Sheet 5-23 *Emergency and Standby Power Systems*.

- END OF SECTION -

SECTION 26 01 00 - GENERAL PROVISIONS FOR ELECTRICAL SYSTEMS**Part 1 General****1.1 Design Requirements**

1. Complete Short Circuit, Protective Device Coordination, and Arc Flash Study to meet requirements of NFPA 70. ARC Flash Study to include new panels and existing equipment being modified.
2. Arc Flash Sign Installation: Implement the Arc Flash sign installation requirements for electrical equipment as specified in NEC Article 110.16 Flash Protection and NFPA 70E.
3. Arc Flash Study: Perform Arc Flash Analysis to include the following at each distribution bus:
 - a Bolted fault current.
 - b Arc fault current
 - c Protective device characteristic and arc fault duration.
 - d System voltages and equipment class
 - e Working distances
 - f Calculated incident energy
 - g Calculated arc flash protective boundary

Part 2 Products**2.1 Materials and Equipment**

1. All materials and equipment used in carrying out these specifications to be American made unless approved otherwise and to be new and have UL listing, or listing by other recognized testing laboratory when such listings are available.

Part 3 Execution**3.1 Tests**

1. On completion of work, installation shall be tested to be entirely free from grounds, short circuits, and open circuits. Balance all circuits so that feeders to panels be not more than 10% out of balance between phases with all available load energized and operating.
2. Furnish Vanderbilt, as a part of closing file, a copy of such tests including identification of each circuit and readings recorded. Test information to be furnished includes ampere readings of all panels and major circuit breakers, insulation resistance reading of motors and transformers.
3. Prior to final observation and acceptance, test, leave in satisfactory operating condition all electrical systems and equipment including but not limited to the following:
 - Electrical distribution system.
 - Ground fault protection system.

SECTION 26 01 00 - GENERAL PROVISIONS FOR ELECTRICAL SYSTEMS

- Emergency power generation system.
- Transformers
- Fire alarm and smoke detection system.
- Electric motors for all equipment.
- Master clock system.
- Electric safety devices.
- Any alarm system, including narcotics, generator, door security, etc.
- Isolation panel ground monitor.
- CCTV system.

3.2 Identification of Equipment

Properly identify all starters, contactors, relays, safety switches and panels with permanently attached black (normal power) or red (essential systems) phenolic plates with 1/4" white engraved lettering on the face of each attached, with two sheet metal screws. Starters and relays connected by the electrical tradesman to be identified by him whether furnished by him or others.

3.3 Temporary Lights and Power

1. Provide a temporary electrical lighting and power distribution system of adequate size to properly serve the following requirements, including adequate feeder sizes to prevent excessive voltage drop. Temporary work to be installed in a neat and safe manner in accordance with the National Electrical Code, Article 590, and as required by OSHA or applicable local safety codes.
2. Provide one pigtail socket with 150 watt lamp for every 1000 square feet of floor area, evenly distributed throughout building and with minimum of one pigtail socket per room.
3. Provide one duplex power outlet for every 1,500 square feet of floor area, evenly distributed throughout the building. Power outlets to be 20 amp, single phase located as directed by the contractor.
4. Provide service and panelboards required for above lighting and power outlets.

3.4 Observations

Specifications and drawings represent work to be done in view of total project requirements. Final location of conduits, fixtures, panels, switchboards, etc., to eliminate possible conflict with other trades is responsibility of Contractor. Contractor to provide all supervision required for his personnel to ensure that installation is made in accordance with specifications and drawings and all safety rules and regulations are observed. In event of conflicts of work on project with other trades, Contractor to make every reasonable effort to resolve conflict through meetings and discussions with other parties involved, by preparation of drawings or other appropriate action.

- END OF SECTION-

SECTION 26 05 00 - MEDIUM VOLTAGE CABLES

Part 1 - General

1.01 Scope

1. This specification covers the general cable, termination, splices, and installation of medium voltage power cable. The installation shall be capable of operating continuously in both wet and dry locations at a conductor temperature of 90 deg C for normal operation.
2. The Cable, Termination, Splices, and installation will be installed in accordance with the National Electrical Code (N.E.C.) and any other attached specification.

Part 2 - Products

2.1 Cable and Armored Cable

1.02 Cable shall be Okonite, General, or Prysmian 15 KV. 133% .220" (5.59mm) copper tape shielded power cables. Meeting or exceeding the requirement of the following specification: ASTM B-8, AEIC CS-6, ICEA S-68-516/NEMA WC-8, N.E.C. ARTICLE 326, UL 1702.

1.03 Ratings: Shielded power cable will be listed by Underwriters Laboratories and designated MV-90. When specified; cables shall also be rated SUNLIGHT RESISTANT, OIL RESISTANT, and sizes 250 MCM and larger for cable tray use shall be marked (CT).

1.04 Qualifications: All shielded power cable will be OSHA acceptable. Manufacturer will furnish to Vanderbilt University in writing that the cable meets or exceed all specifications.

2.2 Identification

The outer jacket of the cable shall be printed with the following information at two-foot intervals maximum in accordance with the NEC Article 310-11:

1. Manufacturer's name.
2. Conductor size.
3. Voltage rating.
4. "Direct Burial" (Multi-conductor only).
5. Identification of the insulation type.
6. "Sunlight-Resistant for CT USE", in accordance with the NEC Article 318.
7. Year and place of manufacturer.
8. UL Type MV-105. 2.4KV shall be rated MV90.

2.3 Terminations

1. Terminations: Shall be for use on copper tape shielded, or concentric neutral power cable, size range: 15kv - #2 AWG - 1500 MCM (15kv - 133%), 15kv Rated: 110kv BIL.
2. Class 1 Termination IEEE ST NO. 48 1975
3. 3M QUICK TERM 2 HI - K Silicone Rubber Termination Kits for shielded cable number 5633k, 5635k, 5636k, 5637k. (Use outdoor cold shrink splice kit, unless written consent from Vanderbilt University has been received).

SECTION 26 05 13 - MEDIUM VOLTAGE CABLES

2.4 Inline and Tee Splices

Splices: Shall be 3M or Raychem Cold Shrink Splice Kit, 5700 Series, for copper shielded cable 15kv 133%. Splices shall have a clear protective coating after completion and conforming to Federal Specification TT-L-50F. Power cable circuits may be spliced only at locations where specified. Splices shall not be made to utilize short lengths of cable, nor shall they be made to provide correct lengths on cable initially cut too short for a circuit. Splices shall be made with a tin-plated copper compression connector and a compression tool as approved by the manufacturer of the connector. Tool shall be of the hydraulic pump type or the type that crimps to the required size before releasing. Electrical voltage stresses shall be controlled by utilization of high permittivity, high resistivity, heat shrinkable polymeric tubing. The splice shall be sealed with a heat activated adhesive and an outer heat shrinkable jacket tubing. Splice shall provide continuity of the cable shield using a wire mesh and grounding clamps.

2.5 Conductors

1. Conductors to be annealed, Class B compact stranded copper per ASTM B-8, ICEA S-93-639, and ICEA S-97-682.

2.6 Shield/Neutral

1. Shield to be bare 5-mil minimum thick copper tape helically applied over the extruded insulation with 25% nominal overlap.
2. Shield shall contain a fully rated, copper, concentric neutral.

2.7 Jacket

1. Jacket to be flame-resistant, low-friction Polyvinyl Chloride Cable shall be rated for direct burial in accordance with the NEC.
2. Jacket to be low-density polyethylene jacket covering shield or neutral use in accordance with NEC Article 318.
3. Jacket to be covered with CLX metal clad armor or approved equal.

2.8 Installation

1. Cable shall be installed in a workman like manner. Pulled only by the center conductor. Shields will be treated as per any other conductor. Ground shield at source end of cable only.
2. Manholes, and Cable Trays - Cable will have 3M Fire and Arc Proofing Tape installed, two (2) layers 1/2 wrap. All cables shall be grouped together and in the groups shall be of ABC phase.
3. Splices and Termination shall only be installed by a cable splicer with experience and qualifications acceptable to Vanderbilt University.
4. After all cable, splices, and terminations are installed they shall be testing according to NETA Specifications by an independent testing company or Vanderbilt University. All information will be given to Vanderbilt University in writing.

SECTION 26 05 13 - MEDIUM VOLTAGE CABLES

5. Parallel circuits must be identical in length and grouped together in ABC phase groups.

Part 3 - Execution

3.1 Delivery and Storage

1. All reels shall be shipped in the upright position. Any reels arriving in a “flopped” on the flange (side) position will be received and inspected subject to hidden damage and shall be noted on the bill-of-lading and signed by the freight carrier. The contractor or other person receiving the material shall be responsible for inspection for damages and contacting the supplier immediately upon receipt of any damaged material.
2. All cable shall be stored in an upright position.
3. Manufacturer shall seal the cable ends to prevent the entrance of moisture.
4. After the cutting of any lengths, the exposed ends of any remaining cable on the reel shall have heat-shrinkable end caps applied to prevent the entrance of water or vapor.
5. All cables shall be transported and handled in accordance with the manufacturer’s recommendations.
6. Cable should be stored under cover or, if not possible, covered by opaque plastic or canvas. Reels under the covering should have adequate ventilation to prevent the formation of condensation.

3.2 Installation

1. The installer shall assume responsibility for exercising care and good judgment in the transportation, handling, installation, splicing, terminating and testing of the cable using acceptable industry practice and testing standards. Cable pulling stress calculations shall be performed to assure that all circuits are installed in strict accordance with the physical limits of the cables as stated by the manufacturer, and a stress factor meter shall be used with printable log.
2. Deliver all conductors to job site new and in original wrapping, package or reel.
3. The installer shall provide satisfactory written documentation and references as to their experience in splicing and terminating medium-voltage power cable.
4. Ground terminations with #6 copper insulated to 600 volts as detailed on the drawings.
5. Use UL listed and cable manufacturer pulling compound to pull conductors. Grease is not acceptable.
6. Include 600-volt insulated ground as shown and sized on the drawings.
7. All conductors and connections shall test free of grounds, shorts, and opens.
8. Label all circuits with imprinted labels. Stick-on labels are not allowed. Labels shall be installed at all manholes and termination cabinets.

SECTION 26 05 13 - MEDIUM VOLTAGE CABLES

3.3 Cable Placement

1. Cable shall be carefully checked and tested to verify the electrical condition, size, and length before being pulled into raceways. Cable pulled into the incorrect raceway or cut too short to rack, train, or splice as specified herein shall be removed and replaced by and at the expense of the Contractor.
2. Cable in Manholes: Cable shall be supported at all times during handling. Cable ends shall be sealed to prevent the entry of moisture or dirt. Cable racks or trays shall be provided for permanent support. Temporary support required during placement shall be with rope slings, timbers, or alternate method acceptable to Vanderbilt.
3. Supports: Cable supports and securing devices shall have bearing surfaces oriented parallel to the surfaces of the cable sheath and shall be installed to provide adequate support without deformation of the cable jackets or insulation. Adequate cable end lengths shall be provided and properly placed in electrical equipment or manholes to avoid longitudinal strains and distorting pressures on the cable at termination points and duct end bells. Final inspection shall be made after all cable is in place. Where supports, bushings, and end bells deform the cable jacket, additional supports shall be provided as directed by Vanderbilt.

3.4 Cable Racks

Cable racks shall be furnished and installed as required to provide the proper cable support. Cable racks shall be installed and spaced 36 inches apart and bolted to permanent wall surfaces with anchors or continuous slot concrete inserts. Ground metal arms on cable racks if used.

3.5 Moisture Seals

Cable ends shall be kept sealed except when termination and splicing work is being performed. Seal with heat-shrinkable caps with the sizes recommended by the cap manufacturer for the cable outside diameter and insulation. Caps shall contain sufficient adhesive that shrinkage of the cap during application results in formation of a positive, watertight seal. Heat-shrinkable caps shall be "Thermofit" as manufactured by Raychem Corporation or equal.

Before and after pulling, the leading end seal of each length of cable shall be examined and replaced if necessary. All cut cable ends shall be promptly sealed after cutting except those to be spliced or terminated immediately.

3.6 High Voltage Testing

1. Each conductor of each run shall be tested for insulation integrity prior to energizing. The tested conductor shall include all splices, terminations, and the overall length of conductor, but SHALL NOT include switchgear, transformers, nor lightning arresters. The test shall include 10 to 15 minutes of exposure to D.C. high voltage with leakage current values monitored, recorded, and supplied to the engineer in graphical form. The cable shall be tested in accordance to the manufacturer's recommendations.
2. Test Duration: 10 to 15 minutes. If the leakage current quickly stabilizes the test duration may be reduced to ten minutes.

SECTION 26 05 13 - MEDIUM VOLTAGE CABLES

3. Test Type: D.C. high voltage.
4. Test voltage for new cable shall be 15 KV, 220 mils, 65KV.
5. Test voltage for existing cable less than five years old shall be as listed below.
 - a. 5 KV, 20KV.
 - b. 15 KV, 60KV.
6. Cable Test Report: The currents resulting from the DC high potential testing shall be recorded and provided to Vanderbilt. Test results shall demonstrate that the leakage current decreases or remains constant after reaching the specified test voltage.

-END OF SECTION-

SECTION 26 05 19 - ELBOWS AND CONNECTORS

Part 1 - General

This section governs the installation of cable stress cones, load break and dead break elbows, and dead front "T's". Provide approved connections for various wire sizes.

Part 2 – Products

2.1 Twist-on connectors - for connecting No. 8 AWG and smaller shall be rated 600 volts consisting of metal spring, steel shell and color coded long skirted PVC insulator. The connector shall be a UL listed connector.

1. **Bolted-pressure connectors** - for conductors No. 6 AWG and larger are to be of a cast non-ferrous material.
2. **Compression-type connectors** - for conductors No. 6 AWG and larger are to be a pressed non-ferrous material.

2.2 Stress Cones

1. Live front stress cones shall be 3M-7600 Series termination (cold shrink type) with grounding kits. Rated 15 KV as required. Raychem Heat Shrink type of equal rating is also acceptable.
2. Acceptable manufacturers include Raychem, 3M, and Cooper.

2.3 Elbows and Connectors

1. Applicable Standards: The 200 Amp Load-break and Dead-break elbow connectors and 630 Amp Dead-break bolted tee connectors purchased under this specification shall comply with the following standards:
 - ANSI/IEEE Standard 386: Separable Insulated Connectors for Power Distribution Systems above 600V.
 - IEEE Standard 592 (Included in the Standard Above): IEEE Standard for Exposed Semiconducting Shields on Pre-molded High Voltage Cable Joints and Separable Insulated Connectors.
2. Service Conditions: Modular insulated connectors shall be suitable for use under the following service conditions:
 - In air, including exposure to direct sunlight.
 - Intermittently or continuously submerged in water.
 - Environmental temperature between -20 degrees C to 65 degrees C.

SECTION 26 05 19 - ELBOWS AND CONNECTORS

3. Ratings:

- Phase to phase voltage = 14.4 KV.
- Phase to Ground = 8.3 KV. 3. BIL = 95 KV.
- Current = 200 Amp or 600 Amp as required.

4. Manufacturers:

- 200 Amp LB Elbow Connector, 15 KV - 36 KV: Cooper LE series, with capacitive test port, or equal.
- 200 Amp and 400 Amp DB Elbow Connector, 15 KV - 36 KV: Cooper DE series, with capacitive test port, or equal.
- 630 Amp DB Bolted Tee Connector, 24 KV - 36 KV: Cooper DT series, with capacitive test port, or equal.

Part 3 – Execution

- 31** Make connections, splices, taps and joints with solderless devices, mechanically and electrically secure. Protect exposed wires and connecting devices with electrical tape or insulation to provide not less than that of the conductor.
- 32** Bolted-pressure connectors shall be applied to the conductor by clamping with a minimum of two bolts and providing a phenolic insulated cover rated 600 volts.
- 33** Compression connectors shall be applied to the conductor by mechanical crimping pressure and insulated for 600 volts.
- 34** Install in strict compliance with manufacturer requirements and industry standard. Ground units as shown on the drawings. Exercise care to keep units clean and install with neat workmanship. Test units with cable as set forth in the cable sections.

-END OF SECTION-

SECTION 26 05 23 - LOW VOLTAGE ELECTRICAL POWER CONDUCTORS AND CABLES**Part 1 - General**

Provide wire, cable and connections to electrical devices and systems via a raceway system.

Part 2 - Products

1. Conductors for branch circuits and feeders shall be 600 volt, UL approved, copper.
2. For fire alarms and control systems, use stranded wire minimum #18 gauge conductors labeled "THHN" or "THWN."
3. Use stranded copper, type "THHN" or "THWN" for conductors #8 and larger, except when required by code.
4. MC cable shall not be used in new construction and may only be used in renovations with the prior written approval of the Project Manager.

Part 3 - Execution

1. No conductor for branch circuit wiring shall be smaller than #12.
2. Complete conduit system and install bushings before pulling any wire or cable. Conductors shall be continuous from outlet to outlet or to branch circuit over current devices.
3. Make splices only in junction boxes. Splices shall not be made in panelboards. Splices in pull boxes where conductors are not being tapped and other unnecessary splices will not be permitted.
4. Provide a separate insulated ground wire for all power branch circuit wiring. Ground conductors to be installed in conduit.
5. Conductors shall be color coded to differentiate between systems of different voltage and to differentiate between phases of each system. Color coding shall be consistent throughout so that across phases and voltages the given phase of a given system shall always be the same color. Colors for 120/208 volt systems shall be Black, Red, and Blue. Colors for 480 volt shall be Brown, Orange and Yellow.
6. All 120 volt branch circuit, including light circuits, shall have their own neutral (no shared neutral).

-END OF SECTION-

SECTION 26 05 33 - RACEWAYS AND BOXES FOR ELECTRICAL SYSTEMS**Part 1 – General****Part 2 - Products**

Rigid conduit, intermediate metallic conduit, & electrical metallic tubing to be hot dipped, galvanized, or electro-galvanized steel that is NEC approved by Triangle, Allied, or Raco.

For interior EMT conduit connectors from 1/2" to 2" trade sizes shall use set screw type. For interior EMT conduit connectors from 2-1/2" to 4" trade sizes shall use two set screw type.

For exterior EMT conduit connectors from 1/2" to 4" trade sizes shall use compression type.

Part 3 - Execution

1. Minimum size of conduits shall be 3/4 inch (1/2 inch permissible for switch legs).
 2. Provide approved raceways for all electrical wiring.
 3. Use electrical metallic tubing where drawings call for conduit to be concealed in walls, run exposed (except in powerhouse applications), and installed above suspended ceilings.
 4. Use only rigid galvanized steel, or intermediate galvanized steel conduit when installed exposed in powerhouse applications, and for feeders, unless approved in writing by the Project Manager.
 5. All lighting and power conductors shall be installed in conduit.
 6. Run exposed conduit at right angles to, or parallel to walls.
 7. Conduit shall be supported directly from the building structure. Use caddy clips, beam clamps, conduit straps, or other steel supports designed for the purpose. Electrical tape, plastic ties, plumbing strap, and tie wire will not be permitted.
 8. Use short pieces, approximately two feet in length, of flexible conduit to connect motors and other devices subject to motion and vibration. Connectors for flexible conduit shall be steel.
 9. Use expansion fittings properly bonded to assure ground continuity across expansion joints in floors and ceilings. Use double lock nuts and bushings on panel feeders at panel enclosures.
 10. Connectors and couplings for electrical metallic tubing shall be compression type or set screw type according to NEC Code.
 11. All empty conduits shall have a galvanized steel pull wire or a nylon pull string.
 12. Conduit shall not be permitted to pass through elevator shafts or elevator equipment rooms.
 13. Flexible conduit shall not exceed 6' in length above ceiling and may not be used inside walls.
 14. Provide grounding bushings on all feeder conduits in accordance with NEC Article 517.
- END OF SECTION-

SECTION 26 05 43 - UNDERGROUND ELECTRICAL SERVICE**Part 1 - General****1.01 Scope - Underground Electrical Raceway Systems****Part 2 - Products**

1. Duct lines to be rigid PVC Schedule 40.
2. Concrete: 3000 psi type with maximum aggregate of 3/4 inch.

Part 3 - Execution

1. All duct-banks to sit in undisturbed soil. Where backfill under duct-banks is required, thoroughly compacted pit run gravel to be installed in 6 inch lifts.
 2. Duct-bank to be supported on plastic duct spacers to maintain 3 inch separation between the ducts and to hold ducts 3 inches clear of trench bottom. All ducts to be securely anchored down to prevent floating or displacement when concrete is poured.
 3. Reinforcing rod and band ties to be provided over entire length of duct-banks.
 4. Concrete to be thoroughly rodded to flow between and under all ducts.
 5. No trapped ducts will be permitted. Ducts must slope to manholes, pullboxes, or entrance to building for drainage.
 6. Manholes shall be sized as shown on detailed drawings with pulling eyes in walls and lifting irons in the floor. All manholes to be externally waterproofed and provided with water tight manhole covers. Provide drain for all manholes and sump pumps where possible.
 7. Where ducts enter buildings provide 10 feet lengths of rigid steel conduit in lieu of PVC from duct-banks to point where ducts enter the building.
 9. Clean and swab all ducts and install light waterproof cord in all ducts. Cap spare ducts at manhole locations.
 10. Install at least 2 spare conduits, equal in size to the largest conduit in the duct bank, in duct-banks.
 11. All abandoned conductors shall be removed.
 12. Exact dimensioned routing of duct-banks to be clearly indicated on as-built drawings.
 13. Make internal inspection of manholes 3 months after completion of construction for indications of water ingress. Where leakage is noted, remove water and seal leak sources. Re-inspect after 2 months and reseal remaining leak sources. Repeat process at 2 month intervals until leaks are corrected.
- END OF SECTION -

SECTION 26 05 73 - OVERCURRENT PROTECTIVE DEVICE COORDINATION**Part 1 - General****1.1 Summary**

- A. Section includes short circuit, protective device coordination, and arc flash study encompassing portions of electrical distribution system from normal power source or sources up to and including main breaker in each panelboard.
- B. Contractor shall engage services of independent engineering firm for purpose of performing electric power system studies as specified.

1.2 Design Requirements

- A. Complete Short Circuit, Protective Device Coordination, and Arc Flash Study to meet requirements of NFPA 70 and NFPA 70E.
- B. Short Circuit Report Preparation:
 - 1. Prepare study prior to ordering distribution equipment to verify equipment ratings required.
 - 2. Perform study with aid of computer software program.
 - 3. Calculate short circuit interrupting and, when applicable, momentary duties for assumed 3-phase bolted fault short circuit current and phase to ground fault short circuit current at each of the following:
 - a. Utility supply bus.
 - b. Medium voltage air interrupter switchgear.
 - c. Medium voltage circuit breaker switchgear.
 - d. Secondary unit substations.
 - e. Automatic transfer switch.
 - f. Manual transfer switch.
 - g. Engine generator.
 - h. Medium voltage motor controllers.
 - i. Medium voltage oil switchgear.
 - j. Low-voltage switchgear.
 - k. Switchboards.
 - l. Motor control centers.
 - m. Distribution panelboards.
 - n. Branch circuit panelboards.
 - o. Each other significant equipment location throughout system.
- C. Short Circuit Report Contents:
 - 1. Calculation methods and assumptions.
 - 2. Base per unit value selected.
 - 3. One-line diagram.

SECTION 26 05 73 - OVERCURRENT PROTECTIVE DEVICE COORDINATION

- a. Source impedance data including power company system available power and characteristics.
 - b. Typical calculations of:
 - 1) Fault impedance.
 - 2) X to R ratios.
 - 3) Asymmetry factors.
 - 4) Motor fault contribution.
 - 5) Short circuit kVA.
 - 6) Symmetrical and asymmetrical phase-to-phase and phase- to-ground fault currents
 - 7) Tabulations of calculation quantities and results.
 8. One-line diagram revised by adding actual instantaneous short circuits available.
 9. State conclusions and recommendations.
- D. Overcurrent Protective Device Coordination Study:
1. Prepare time-current device coordination curves graphically indicating coordination proposed for system, centered on conventional, full-size, log- log forms.
 2. Prepare with each time-curve sheet complete title and one-line diagram with legend identifying specific portion of system covered by that particular curve sheet.
 3. Prepare detailed description of each protective device identifying its type, function, manufacturer, and time-current characteristics. Tabulate recommended device tap, time dial, pickup, instantaneous, and time delay settings.
 4. Plot device characteristic curves at point reflecting maximum symmetrical fault current to which device is exposed. Include on curve sheets the following as applicable:
 - a. Power company relay characteristics.
 - b. Power company fuse characteristics.
 - c. Medium voltage equipment protective relay characteristics.
 - d. Medium voltage equipment protective fuse characteristics.
 - e. Low voltage equipment circuit breaker trip device characteristics.
 - f. Low voltage equipment fuse characteristics.
 - g. Cable damage point characteristics.
 - h. Pertinent transformer characteristics including:
 - 1) Transformer full load current
 - 2) Transformer magnetizing inrush.
 - 3) ANSI transformer withstand parameters.
 - 4) Significant symmetrical fault current
 - i. Pertinent motor characteristics.
 - j. Generator characteristics including:
 - 1) Phase and ground coordination of generator protective devices.
 - 2) Decrement curve and damage curve.
 - 3) Operating characteristic of protective devices.
 - 4) Actual impedance value.
 - 5) Time constants.
 - 6) Current boost data.
 - 7) Do not use typical values for generator.

SECTION 26 05 73 - OVERCURRENT PROTECTIVE DEVICE COORDINATION

E. Arc Flash Study

1. Perform Arc Flash Analysis to include the following at each distribution bus:

- a) Bolted fault current.
- b) Arc fault current
- c) Protective device characteristic and arc fault duration.
- d) System voltages and equipment class
- e) Working distances
- f) Calculated incident energy
- g) Calculated arc flash protective boundary

1.3 Submittals

A. Product Data: Submit the following:

1. Report: Summarize results of study in report format including the following:

- a. Descriptions, purpose, basis, and scope of study.
- b. Tabulations of circuit breaker, fuse and other protective device ratings versus calculated short-circuit duties, and commentary regarding same.
- c. Protective device time versus current coordination curves, tabulations of relay and circuit breaker trip settings, fuse selection, and commentary regarding same.
- d. Fault current calculations including definition of terms and guide for interpretation of computer printout.
- e. Arc flash calculations and printout of labels.

B. Submit copy of final report signed by professional engineer. Make additions or changes required by review comments.

1.4 Qualifications

- A. Perform study under direct supervision of Professional Engineer experienced in design of this Work and licensed at Project location with minimum of five (5) years of experience in power system analysis.
- B. Demonstrate company performing study has capability and experience to provide assistance during system start up.

Part 2 – Products**Part 3 – Execution****3.1 Adjusting**

- A. Perform field adjustments of protective devices and modifications to equipment to place equipment in final operating condition. Adjust settings in accordance short circuit and protective device coordination study.

SECTION 26 05 73 - OVERCURRENT PROTECTIVE DEVICE COORDINATION

3.2 Arc Flash Sign Installation

- A. Implement the Arc Flash sign installation requirements for electrical equipment as specified in NEC Article 110.16 Flash Protection and NFPA 70E.

- END OF SECTION-

SECTION 26 12 16 - DRY TYPE MEDIUM VOLTAGE TRANSFORMERS**Part 1 General**

1. The transformer shall be 3 - phase, 60 hertz, air-cooled dry type mounted in a suitable ventilated enclosure and barriered from the high voltage and low voltage section. Self-cooled capacity (size as required) primary voltage 15kV or dual wound 15kV/4160V; secondary voltage (as required) wye 4 wire. Primary taps shall be full capacity, with minimum of 2-2.5% above and below rated voltage.
2. The transformer shall have a 150 degree C temperature rise above 40 degree C ambient, (or 115 degree C temperature rise above a 40 degree C. ambient) or (80 degree C rise above 40 degree ambient). 115 degree C transformer shall be capable of carrying a 15% continuous overload without exceeding 150 degree C rise in a 40 degree C ambient. All insulating materials used shall be in accordance with NEMA ST 20 or MEMA TR27 Standards for 220 degree insulating system. The temperature rise shall be designated on the transformer nameplate. Insulating liquid shall be bio-degradable mineral oil.
3. The coil design shall be copper modified winding to provide the most efficient, reliable, and compact winding.
4. The completed coil shall be pre-heated, vacuum-impregnated with non-hygroscopic, thermosetting insulating varnish, and then thoroughly baked. This process shall completely seal the coils against moisture, and eliminate any voids which could create hot spots, or cause corona formation.
5. The transformer cores are to be constructed of high grade, non-aging silicon steel laminations with high magnetic permeability, and low hysteresis and eddy current losses. Magnetic flux densities are to be kept well below saturation point. The core lamination shall be clamped together with heavy structural steel angles.
6. The basic impulse level (BIL) shall be a minimum of 90K for the 15kV class.
7. The enclosure shall be constructed of heavy gauge sheet steel. All ventilating openings shall be in accordance with NEMA and National Electrical Code standards for ventilated enclosures. Large enclosures are to be provided with lifting devices bolted or welded to the base structure, and shall have jacking pads designed to be flush with the enclosure. The base is to be constructed of structural steel members to permit skidding or rolling in any direction. The enclosure is to be cleaned, phosphatized, primed and finished with gray, baked enamel. Provide 1" drain valve with sampling device accessible outside the enclosure.
8. Metal oxide gapless type lightning arrester, or equivalent, shall be installed by the manufacturer on the high voltage side of the transformer to provide additional protection against high voltage lightning or switching surges.

Part 2 Products

1. Acceptable manufacturers are GE, ABB, Cutler Hammer, and Square D.

SECTION 26 12 16 - DRY TYPE MEDIUM VOLTAGE TRANSFORMERS

2. Include nameplate diagram with the following ratings:

- kVA
- Primary and Secondary Voltage
- Taps
- Basic Impulse Level
- Impedance
- Oil Type (Non-PCB)

Part 3 Execution

- END OF SECTION-

SECTION 26 13 16 - MEDIUM VOLTAGE FUSIBLE INTERRUPTER SWITCHGEAR**Part 1 – General**

Medium voltage load interrupter metal enclosed switchgear, single section indoor construction as described. This equipment is to meet NEMA, ANSI and IEEE standards.

Part 2 - Products

1. The completed metal enclosed switchgear shall have the following electrical ratings: Maximum Design

Voltage	-	5 kV / 15kV
BIL	-	kV 60
Continuous Amperes	-	600A
Momentary Current	-	61000A
Fault Close	-	40000A
Main Bus Rating	-	600, 1200 or 2000 Amperes

2. The manufacturer of the switchgear shall be the same as designer manufacturer of the load break switch. The enclosures, fuses, switches and operator shall be coordinated to assure a fully integrated system assembly.
3. The metal enclosed switchgear shall be GE, Eaton, or Square D.
4. SF6 switchgear shall be S & C or approved equal.
5. The transformer shall be Square D, Cooper Power, Olson or GE.
6. The transformer shall have copper main bus.
7. Relays should be Multilin series 800 or approved equal.

Part 3 –Execution**3.1 Construction**

1. Each switch bay shall be a separate constructed cubicle assembled to form a rigid free standing unit. Adjacent bays shall be securely bolted together to form an integrated rigid structure. To assist installation and maintenance of bus and cables, the individual unit shall be removable. Each individual unit shall be braced to prevent distortion.
2. Provisions shall allow for convenient extension of both the main bus and the ground bus to adjacent bays which may be added in the future. The main crossover bus is to be furnished and supported from the top of the enclosure on NEMA glass polyester insulators. The ground bus shall run continuously through the entire line-up and shall be securely connected to the steel frame of each bay.

SECTION 26 13 16 - MEDIUM VOLTAGE FUSIBLE INTERRUPTER SWITCHGEAR

3. The metal enclosed gear shall be fully assembled and tested at the factory prior to shipment. Larger line-ups shall be split to permit normal shipping and handling as well as for ease of rejoining at the job site.

3.2 Load Interrupter Switches

1. Switches shall be quick-make, quick-break with the speed of opening or closing entirely independent of the operator. The load interrupter switches shall be three pole, two position, with a stored energy spring mechanism to provide quick switch operation independent for in-air operation of the flipper blade/arc chute type for ease of inspection and maintenance.
2. Switch operating handle shall be permanently mounted and ready for immediate use. The spring sleeve permits the handle to fold down when the switch is in the open position. Provisions shall be available for padlocking the switch in either the open or closed position. Switch is to have 600A continuous and interrupting rating as indicated on plans or in the bill of material.
3. A viewing window shall be installed in the switch enclosure and located to enable visible inspection of the switch poles from the enclosure, and so placed that opening the fuse access door is not required to observe the blown fuse indicator on any fused switch.
4. SF6 switches shall be assembled in totally welded ¼" Type 304L stainless steel tank with attached fill valve.

- END OF SECTION-

SECTION 26 18 16 - MEDIUM VOLTAGE FUSES**Part 1 General**

1. The high voltage fuses and non-disconnecting fuse mountings shall be accessible only through a separate door mechanically interlocked with the load break switch, to insure the switch is in the open position when the fuses are accessible. Switch designs with full height fuse access doors shall have a solid barrier covering the area of the main cross bus and/or line side of the switch. Metal screen barriers are not acceptable. No energized parts shall be within normal reach of the opened doorway. Four single full-length inter-phase barriers shall isolate the three phases of the switch from each other and from the enclosure.
2. Fuses shall be: Current limiting type of self-contained design to limit the available fault current stress on system; and shall have interrupting capacity shown.
3. Fuses shall be affixed in position with provision for removal and replacement from the front of the gear without the use of special tools. Furnish one spare set of fuses for each different size fuse provided in the switchgear.
4. Fuses shall be OEM Approved or equivalent.

Part 2 Products**Part 3 Execution**

- END OF SECTION-

SECTION 26 24 13 - CIRCUIT BREAKER DISTRIBUTION SWITCHBOARDS**Part 1 - General****1.1 System Description**

The power system feeding the Switchboard is either 208 or 480 volts, 60 Hertz, 3 phase, 4 wire, solidly ground wye.

Manufacturer warrants equipment to be free from defects in materials and workmanship for 1 year from date of project acceptance.

Part 2 - Products

2.1 Acceptable manufacturers: General Electric Company, Square D, Cutler-Hammer.

2.2 Components**A. Standard Features:**

1. Switchboards shall be fully self-supporting structures with 90 inch tall vertical sections (excluding lifting eyes and pull boxes) bolted together to form required arrangement.
2. Switchboard(s) shall be NEMA 1 for interior, NEMA 3R for exterior deadfront construction.
3. Switchboard frame shall be die formed, 12 gauge steel with reinforced corner gussets. Frame shall be rigidly bolted to support cover plates (code gauge steel), bus bars and installed devices during shipment and installation.
4. All sections may be rolled, moved or lifted into position. Switchboards shall be capable of being bolted directly to the floor without the use of floor sills.
5. All switchboard sections shall have open bottoms and removable top plate(s) to install conduit.
6. Series rated switchboards are not acceptable.
7. All covers shall be fastened by hex head bolts.
8. Provide hinged doors over metering compartments and individually mounted device compartments. All doors shall have concealed hinges and be fastened by hex head bolts.
9. Switchboard protective devices shall be furnished as listed on drawings and specified herein, including interconnections, instrumentation and control wiring. Switchboards and devices shall be rated for the voltage and frequency listed on the drawings.
10. Switchboard current ratings, including all devices, shall be based on a maximum ambient temperature of 25 degree C per UL Standard 891. With no derating required, temperature rise of switchboards and devices shall not exceed 65 degrees C in a 25 degree C ambient environment. Switchboard Service Entrance sections shall comply with UL Service Entrance requirements including a UL service entrance label, incoming line isolation barriers, and a removable neutral bond to switchboard ground for solidly grounded wye systems.

SECTION 26 24 13 - CIRCUIT BREAKER DISTRIBUTION SWITCHBOARDS**B. Bus Bars**

1. Bus bars shall be continuously silver-plated copper. Bus bars shall have sufficient cross sectional area to meet UL 891 temperature rise requirements. Phase and neutral bus ampacity shall be as shown in plans. For 4-wire systems, neutral shall have same ampacity as phase bus bar.
2. Bus bars shall be mounted on high impact, non-tracking insulated supports. Joints in the vertical bus are not permitted.
3. Bus bars shall be braced to withstand mechanical forces exerted during short circuit conditions as indicated in drawings, but in no case less than 65KA RMS SYM.
4. Bus joints shall be bolted with Grade 5 bolts and Belleville type washers.
5. Ground Bus shall be sized to meet UL 891. Ground bus shall extend full length of switchboard.
6. A-B-C bus arrangement (left to right, top to bottom, and front to rear) shall be used throughout to assure convenient and safe testing and maintenance. Where special circuitry precludes this arrangement, bus bars shall be labeled.
7. All feeder device line and load connection straps shall be rated to carry current rating of device frame (not trip rating).
8. The main incoming bus bars shall be rated for the main protection device frame size or main incoming conductors, if there is no main device.
9. Main horizontal bus bars shall be fully rated and arranged for future extensions.

C. Main Incoming Compartment

1. All lugs shall be tin-plated aluminum and UL listed for use with copper cable. Lugs shall be rated for 75 degree C. cable.
2. Provide crimp compression type lugs in the quantity and size required per the contract drawings.
3. Furnish switchboard(s) with a transition for close coupled connection to a transformer.

D. Feeder Device

1. Feeder devices shall be group mount molded case circuit breakers or when larger than 1200 amps shall be individually mounted insulated case circuit breakers. Provide devices as specified in appropriate article below.
2. Where indicated on the drawings, feeder circuit breakers with trip ratings greater than 250 amperes to 1000 amperes shall be UL listed as 100 percent continuous duty rated.
3. Series rated feeders are not acceptable.

E. Molded Case Circuit Breakers

1. Thermal magnetic molded case circuit breakers may be provided for trip ratings 800 amps and below.
2. Group mounted breakers shall be modular mounted. The module shall be electrically connected to the switchboard bus by spring reinforced jaws. Mechanical connections to panel frame shall be separate from electrical connections. Mechanical connections shall be self-aligning, spring loaded locking devices. Locking device handles shall be able to be bolted to each side of the device to prevent accidental release of electrical connections.

SECTION 26 24 13 - CIRCUIT BREAKER DISTRIBUTION SWITCHBOARDS

3. Individually mounted molded case circuit breakers shall be stationary mounted.
4. Circuit breaker frames shall be constructed of a high-strength, molded, glass-reinforced polyester case and cover. Breakers shall have an over-center, toggle handle-operated, trip free mechanism with quick make, quick break action independent of the speed of the toggle handle operation. The design shall provide common tripping of all poles. Breakers shall be suitable for reverse feeding.
5. Breakers shall have ON and OFF position clearly marked on escutcheon. Breakers shall include a trip-to-test means on the escutcheon for manually tripping the breaker and exercising the mechanism and trip latch.
6. Breakers shall include factory installed mechanical lugs. Lugs shall be UL listed and rated 75 or 60/75 degrees C as appropriate. Breakers shall be standard, or 80 percent rated.

F. Insulated Case Circuit Breakers

1. Insulated case circuit breakers shall be individually mounted.
2. Breakers shall be constructed of a high dielectric strength, glass reinforced insulating case. The interrupting mechanism shall be arc chutes. Steel vent grids shall be used to suppress arcs and cool vented gases. Interphase barriers shall isolate completely each pole.
3. Breakers shall contain a true two-step stored energy operating mechanism which shall provide quick make, quick break operation with a maximum five cycle closing time. Breakers shall be trip free at all times. Common tripping of all poles shall be standard.
4. Insulated Case circuit breakers shall be rated to carry 100 percent of their frame ampacity continuously.
5. A charging handle, close push-button, open push-button, and Off/On/Charge indicator shall be located on the breaker escutcheon and shall be visible with the breaker compartment door closed.
6. Where drawout breakers are specified, the drawout design shall permit the breaker to be withdrawn from an engaged position, to a test position, and to a disengaged position.
7. Breaker digital electronic trip units shall be as described in Article 2.2.I.

G. Digital Electronic Trip Unit for Circuit Breakers

11. The digital electronic trip unit shall consist of a solid state, microprocessor based programmer; tripping means; current sensors; power supply and other devices as required for proper operation.
12. As a minimum, the trip unit shall have the following protective functions:
 - a. Adjustable current setting or long time pickup.
 - b. Adjustable long time delay.
 - c. Adjustable instantaneous pickup.
13. As a minimum, the trip unit shall include the following features:
 - a. Long time and short time protective functions, if provided, shall have true RMS sensing technology.
 - b. Ground fault protective function, if provided, shall contain a memory circuit to integrate low level arcing fault currents with time, to sum the intermittent ground fault spikes.
 - c. High contrast liquid crystal display (LCD) unit shall display settings, trip targets, and the specified metering displays.
 - d. Multi-button keypad to provide local setup and readout of all trip settings on the LCD.
 - e. UL Listed interchangeable rating plug. It shall not be necessary to remove the trip unit to change the rating plug.
 - f. An integral test jack for testing via a portable test set and connection to a battery source.

SECTION 26 24 13 - CIRCUIT BREAKER DISTRIBUTION SWITCHBOARDS

- g. A mechanism for sealing the rating plug and the trip unit.
- h. Noise immunity shall meet the requirements of IEEE C37.90.
- i. Display trip targets for long time, short time, and ground fault, if included.

2.3 Furnish a multi-function electronic meter as described below and where indicated on the drawings.

- D.** The electronic meter shall be a draw-out, semi-flush mounted, microprocessor based, programmable electronic device used for electrical metering. The meter shall be capable of being applied on systems up to 6,000 amps and 600V with required inputs from current transformers, voltage transformers, and/or control power. The display meter shall have built-in communications for Modbus/TCP and BACnet/TCP protocols. The meter shall include a keypad for user programming and display selection.
- E.** The meter shall have a two line LCD display with a minimum of 16 characters per line. The LCD display shall be backlit to facilitate easy reading.
- F.** The meter shall be auto-ranging and capable of metering the following values: amps for each phase; voltage, L-L and L-N; watts; VARs; volt-amperes; power factor; watt-hours; var-hours; current demand; peak current; watt demand; peak watt demand; frequency and harmonic distortion.
- G.** The display meter shall permit the user to define a password to provide security protection. The device setup and all user defined values/settings shall be accomplished by entering the information into the device via a push-button keypad on the front of the face plate.
- H.** The meter shall be capable of communicating on a network and shall be able to communicate all recorded/calculated values to the host computer.
- I.** The meter shall meet applicable ANSI standards and be listed to UL 508 and UL 1244.
 - 1. Waveform capture shall be provided as part of the meter electronics. The waveform shall be captured on demand or when the current exceeds a user-defined threshold. The threshold shall be defined via the keypad. It shall be possible to communicate the captured data to a host computer. The waveform analysis shall be accomplished by an algorithm running as part of the software.
 - 2. The meter shall include two programmable pulse outputs. Pulses shall be programmable for KWH, KVAH, KVARH, or KQH. Output contacts shall be form C type rated for 100 milliamperes at 120 volts.
- J. Communications Compartment**
 - 1. Provide a compartment with a front facing hinged door as a central point of connection for all internally located communicating devices to an external Ethernet network.
 - 2. The compartment shall include an Ethernet switch(es) that are factory wired to each communicating device and configured for a single Ethernet connection out to the customer's LAN.
 - 3. The compartment shall have a lockable, hinged door with a functional through-the-door RJ45 network access port. Power for the components in the compartment shall be supplied by a pre-wired, bus-connected control transformer in the compartment that is fused and has a disconnecting means.

SECTION 26 24 13 - CIRCUIT BREAKER DISTRIBUTION SWITCHBOARDS**2.4 Metering Transformers**

- A. All instrument transformers shall be UL listed and classified as indicated in drawings.
- B. Current Transformers shall be multi-tap and wired to terminal block in accessible area while energized and as shown on drawings with burden and accuracy to support connected meters and relays as required by ANSI/IEEE C57.13.
- C. Potential transformers shall be as shown on drawings with burden and accuracy to support connected meters and relays as required by ANSI/IEEE C57.13.

2.5 Auto Throw-over System (for fully redundant Main-Tie-Main System only)

- A. All switchboards shall be provided with a PLC-based closed transition Main-Tie-Main automatic throw-over system.
- B. The Auto Throwover shall be furnished with Voltage Detection Relays (27), Manual/Automatic/Test Selector Switch (43), Test Mode Selector Switch, Control Power Transformer Relay (83), and Sync Check Relay (25).
- C. Push-To-Test, LED pilot lights shall be provided as
 - 1. Yellow, "Sources"
 - 2. White (2), "Source 1 Ctrl Pwr Available", "Source 2 Ctrl Pwr"
 - 3. Blue
 - 4. Clear
 - 5. Amber, "Lockout"
- D. The main breakers shall be electrically interlocked such that both breakers cannot be paralleled unless permissible by the sync check relay.
- E. Normal switchgear operation is with the Mains closed and the Tie open.
- F. The Automatic Throw-over Sequence of Operations shall be exactly as follows:
 - 1. Manual Mode
 - a. With the control switch in Manual, either Main or Tie breaker can be closed by their respective breaker control switch.
 - b. Paralleling of sources is allowed subject to the Sync Check function.
 - c. Long term paralleling of sources shall be disallowed through the use of an Incomplete Sequence Timer. If the sources are left paralleled for more than 60 seconds, the system shall automatically open the tie breaker. The main breakers, and therefore the loads, shall remain unaffected.
 - 2. Automatic Mode
 - a. With the control switch in Auto, Loss of Voltage on either Main will, after a 3 second time delay, cause its main breaker to open and the tie breaker to close.
 - b. When voltage is restored to the opened Main, the system will remain unchanged and will not retransfer. The system shall require an operator to manually reset the system to normal by placing the Mode selector switch in Manual and performing a closed transition transfer.
 - c. If voltage is subsequently lost on the second Main after a transfer has occurred, the system shall remain the same. Once either voltage source returns, the system shall automatically track to the available source.
 - d. Simultaneous loss of both voltage sources will result in the system remaining unchanged.

SECTION 26 24 13 - CIRCUIT BREAKER DISTRIBUTION SWITCHBOARDS

3. Test Mode
 - a. It shall be possible to simulate a loss of voltage by turning the Mode Selector Switch to the "Test" position.
 - b. The "Test Source Selector" Switch will determine which Source simulates the loss of power.
 - c. The system will open the selected Main breaker and close the Tie breaker as described in the "Auto" sequence above, restoring power to the loads.
 - d. To return to normal, the Mode Selector Switch must be set to the "Manual" position for a manual closed-transition return to normal. After the completion of the Test, the Mode Selector Switch should be placed back in "Auto."

2.6 Finish

- A. All steel surfaces shall be chemically cleaned prior to painting.
- B. Exterior paint color shall be Light Gray [ANSI 61] over phosphate - type rust inhibitor.

2.7 Accessories

- A. Outdoor Enclosures
 1. Provide where shown on drawings or indicated in this specification.
 2. Consist of standard indoor cubicles with a front frame and roof assembly to provide a weather resistant structure. Filtered front and rear roof vents.
 3. Front hinged doors with 3 point catch with padlocking provision and wind stop.
 4. Walk-in construction shall have a minimum 30 inch wide clear walk through space.
 5. [Rear hinged doors with 3 point catch with padlocking provision and wind stop.]
 6. Front to rear full depth lifting beams.
 7. Include the following options
 - a. Thermostatic control for space heaters.
 - b. Gasketing.
 - c. LED lighting and convenience outlets.
- B. Furnish nameplates for each device as indicated on drawings.
- C. Furnish screw on plastic strip mimic bus for switchboards.
- D. Furnish automatic breaker throwover equipment. System shall be PLC based.

Part 3 - Execution**3.1 Examination**

- A. The following procedures shall be performed by the Contractor:
 1. Examine installation area to assure there is enough clearance to install switchboard.
 2. Check concrete pads for uniformity and level surface.
 3. Verify that switchboards are ready to install.
 4. Verify that required utilities are available, in proper location and ready for use.
 5. Beginning of installation means installer accepts conditions.

- END OF SECTION

SECTION 26 24 15 - METAL-ENCLOSED DRAWOUT LOW VOLTAGE SWITCHGEAS**Part 1 - General****Part 2 – Products****2.1 Manufacturers**

1. Acceptable manufacturers are Eaton/Cutler-Hammer, GE, Square D, and Siemens.

2.2 Ratings

1. Voltage rating shall be as indicated on drawings. The entire assembly shall be suitable for 600 volts maximum ac service.

2.3 Construction

1. The switchgear shall consist of the required number of vertical sections bolted together to form a rigid assembly. The sides shall be covered with removable bolt-on covers. All edges of front covers or hinged front panels shall be formed. Provide ventilators located on the top of the switchgear over the breaker and bus compartments to ensure adequate ventilation within the enclosure.
2. Each vertical steel unit forming part of the switchgear line-up shall be a self-contained housing having one or more individual breaker or instrument compartments, a centralized bus compartment and a rear cable compartment. Each individual circuit breaker compartment, or cell, shall be segregated from adjacent compartments and sections by means of steel barriers to the maximum extent possible. It shall be equipped with drawout rails and primary and secondary disconnecting contacts. Removable hinge pins shall be provided on the breaker compartment door hinges. Current transformers for feeder instrumentation, where shown on plans, shall be located within the appropriate breaker cells and be front accessible and removable.
3. The stationary part of the primary disconnecting devices for each power circuit breaker shall be breaker mounted and consist of a set of contacts extending to the rear through a glass polyester insulating support barrier; corresponding moving finger contacts, suitably spaced, shall be furnished on the power circuit breaker studs which engage in only the connected position. The assembly shall provide multiple silver-to-silver full floating high pressure point contacts with uniform pressure on each finger maintained by springs. Each circuit shall include the necessary three-phase bus connections between the section bus and the breaker line side studs. Load studs shall be equipped with insulated copper load extension buses terminating in solderless type terminals in the rear cable compartment of each structure.
4. The circuit breaker door design shall be such that the following functions may be performed without the need to open the circuit breaker door: lever circuit breaker between positions, operate manual charging system, close and open circuit breaker, examine and adjust trip unit, and read circuit breaker rating nameplate.

SECTION 26 24 15 - METAL-ENCLOSED DRAWOUT LOW VOLTAGE SWITCHGEAR

5. The secondary disconnecting devices shall consist of floating terminals mounted on the stationary unit and engaging mating contacts at the front of the breaker. The secondary disconnecting devices shall be gold-plated and engagement shall be maintained in the “connected” and “test” positions. The secondary mounted on the stationary unit and engaging mating contacts at the front of the breaker.
6. The removable power circuit breaker element shall be equipped with disconnecting contacts and interlocks for drawout application. It shall have four positions, “connected,” “test,” “disconnected” and “removed.” The breaker drawout element shall contain a worm gear levering “in” and “out” mechanism with removable lever crank. Levering shall be accomplished via the use of conventional tools. Mechanical interlocking shall be provided so that the breaker is in the tripped position before levering “in” or “out” of the cell. Interlocking that trips the breaker will not be accepted. The breaker shall include an optional provision for key locking open to prevent manual or electric closing. Padlocking shall provide for securing the breaker in the connected, test, or disconnected position by preventing levering.
7. An insulating flash shield shall be mounted above each circuit breaker to prevent flashover from the arc chutes to ground

2.4 Bus

1. All bus bars shall be silver-plated or tin-plated copper. Main horizontal bus bars shall be mounted with all three phases arranged in the same vertical plane. Bus sizing shall be based on ANSI standard temperature rise criteria of 65 degrees C over a 40 degrees C ambient (outside the enclosure).
2. Provide a full capacity neutral bus where a neutral bus is indicated on the drawings.
3. A copper ground bus shall be furnished firmly secured to each vertical section structure and shall extend the entire length of the switchgear. The ground bus short-time withstand rating shall meet that of the largest circuit breaker within the assembly.
4. All hardware used on conductors shall be high-tensile strength and zinc-plated. All bus joints shall be provided with Belleville-type washers.

2.4 Wiring/Terminations

1. Small wiring, necessary fuse blocks and terminal blocks within the switchgear shall be furnished as required. Control components mounted within the assembly shall be suitably marked for identification corresponding to the appropriate designations on manufacturer’s wiring diagrams.
2. Provide a front accessible, isolated vertical wireway for routing of factory and field wiring. Factory provisions shall be made for securing field wiring without the need for adhesive wire anchors.
2. Front access to all circuit breaker secondary connection points shall be provided for ease of troubleshooting and connection to external field connections without the need of removing the circuit breaker for access.

SECTION 26 24 15 - METAL-ENCLOSED DRAWOUT LOW VOLTAGE SWITCHGEAR

4. All control wire shall be type SIS. Wire bundles shall be secured with nylon ties and anchored to the assembly with the use of pre-punched wire lances or nylon non-adhesive anchors. All current transformer secondary leads shall first be connected to conveniently accessible shorting terminal blocks before connecting to any other device. Shorting screws with provisions for storage shall be provided. All groups of control wires leaving the switchgear shall be provided with terminal blocks with suitable numbering strips and provisions for #10 AWG field connections. Provide wire markers at each end of all control wiring. Plug-in terminal blocks shall be provided for all shipping split wires. Terminal connections to remote devices or sources shall be front accessible via doors above each circuit breaker.
5. Lugs shall be provided in the incoming line section for connection of the main grounding conductor. Additional lugs for connection of other grounding conductors shall be provided as indicated on the drawings.
6. Reusable insulating boots shall be provided to cover all power cable terminations.

2.6 Circuit Breakers

1. All protective devices shall be low voltage power circuit breakers, Square D Masterpact NW or approved equal. All breakers shall be UL listed for application in their intended enclosures for 100% of their continuous ampere rating.
2. All power circuit breakers shall be constructed and tested in accordance with ANSI C37.13, C37.16, C37.17, C37.50, UL 1066 and NEMA SG-3 standard. The breaker shall carry a UL label.
3. Breakers shall be provided in drawout configuration. The 800, 1600, 2000 and 3200 ampere frame power circuit breakers shall be provided in the same physical frame size, while 4000, 5000 and 6000 ampere frame power circuit breakers shall be provided in a second physical frame size. Both physical frame sizes shall have a common height and depth.
4. Power circuit breakers shall utilize a two-step stored-energy mechanism to charge the closing springs. The closing of the breaker contacts shall automatically charge the opening springs to ensure quick-break operation.
5. Breakers shall be manually operated (MO) unless electrically operated (EO) is indicated on the drawings.
6. Electrically operated breakers shall be complete with motor operators. The charging time of the motor shall not exceed 6 seconds.
7. To facilitate lifting, the power circuit breaker shall have integral handles on the side of the breaker.

SECTION 26 24 15 - METAL-ENCLOSED DRAWOUT LOW VOLTAGE SWITCHGEAR

8. The power circuit breaker shall have a closing time of not more than 3 cycles.
9. The primary contacts shall have an easily accessible wear indicator to indicate contact erosion.
10. The breaker control interface shall have color-coded visual indicators to indicate contact open or closed positions, as well as mechanism charged and discharged positions. Manual control pushbuttons on the breaker face shall be provided for opening and closing the breaker. The power circuit breaker shall have a "Positive On" feature. The breaker flag will read "Closed" if the contacts are welded and the breaker is tripped or opened.
11. A position indicator shall be located on the faceplate of the breaker. This indicator shall provide color indication of the breaker position in the cell. These positions shall be Connect (Red), Test (Yellow), and Disconnect (Green). The levering door shall be interlocked so that when the breaker is in the closed position, the breaker levering-in door shall not open.
12. Each power circuit breaker shall offer front-mounted dedicated secondary wiring points. Each wiring point shall have finger safe contacts, which will accommodate #10 AWG maximum field connections with ring tongue or spade terminals or bare wire.

2.7 Trip Units

1. Each low voltage power circuit breaker shall be equipped with a solid-state tripping system consisting of three current sensors, microprocessor-based trip device and flux-transfer shunt trip. Current sensors shall provide operation and signal function. The trip unit shall use microprocessor-based technology to provide the basic adjustable time-current protection functions. True RMS sensing circuit protection shall be achieved by analyzing the secondary current signals received from the circuit breaker current sensors and initiating trip signals to the circuit breaker trip actuators when predetermined trip levels and time delay settings are reached. Interchangeable current sensors with their associated rating plug shall establish the continuous trip rating of each circuit breaker.
2. The trip unit shall have an information system that utilizes battery backup LEDs to indicate mode of trip following an automatic trip operation. The indication of the mode of trip shall be retained after an automatic trip. A reset button shall be provided to turn off the LED indication after an automatic trip. A test pushbutton shall energize a LED to indicate the battery status.
3. The trip unit shall be provided with a display panel, including a representation of the time/current curve that will indicate the protection functions. The unit shall be continuously self-checking and provide a visual indication that the internal circuitry is being monitored and is fully operational.
4. The trip unit shall be provided with a making-current release circuit. The circuit shall be armed for approximately two cycles after breaker closing and shall operate for all peak fault levels above 25 times the ampere value of the rating plug.

SECTION 26 24 15 - METAL-ENCLOSED DRAWOUT LOW VOLTAGE SWITCHGEAR

5. Trip unit shall have selectable powered and unpowered thermal memory for enhanced circuit protection.
6. The trip unit shall have provisions for a single test kit to test each of the trip functions.
7. The trip unit shall provide zone interlocking for the short-time delay and ground fault delay trip functions for improved system coordination. The zone interlocking system shall restrain the tripping of an upstream breaker and allow the breaker closest to the fault to trip with no intentional time delay. In the event that the downstream breaker does not trip, the upstream breaker shall trip after the present time delay. Factory shall wire for zone interlocking for the power circuit breakers within the switchgear.
8. Circuit breakers shall have individually adjustable ground fault alarm only.
9. The trip unit shall have a 4-character LCD display showing phase, neutral, and ground current. The accuracy of these readings shall be +/- 2% of full scale.
10. The trip unit shall be equipped to permit communication via a network twisted pair for remote monitoring and control.
11. The trip unit shall include a power/relay module which shall supply control to the readout display. Following an automatic trip operation of the circuit breaker, the trip unit shall maintain the cause of trip history and the mode of trip LED indication as long as its internal power supply is available. [except 520] An internal relay shall be programmable to provide contacts for remote ground alarm indication.
12. The trip unit shall include a voltage transformer module, suitable for operation up to 600V, 50/60 Hz. The primary of the voltage transformer module shall be connected internally to the line side of the circuit breaker through a dielectric test disconnect plug.
13. The unit shall be capable of monitoring the following data:
 - a. Instantaneous value of phase, neutral, and ground current
 - b. Instantaneous value of line-to-line voltage
 - c. Minimum and maximum current values
 - d. Watts, vars, VA, watthours, varhours and VA hours
14. The energy-monitoring parameter values (peak demand, present demand, and energy consumption) shall be indicated in the trip unit's alphanumeric display panel.
15. The trip unit shall contain an integral test pushbutton. A keypad shall be provided to enable the user to select the values of test currents within a range of available settings. The protection functions shall not be affected during test operations. The breaker may be tested in the TRIP or NO TRIP test mode.

SECTION 26 24 15 - METAL-ENCLOSED DRAWOUT LOW VOLTAGE SWITCHGEAR

16. Programming may be done via a keypad at the faceplate of the unit or via the communication network.
17. System coordination shall be provided by the following microprocessor-based programmable time-current curve shaping adjustments. The short-time pickup adjustment shall be dependent on the long delay setting.
 - a. Programmable long-time setting
 - b. Programmable long-time delay with selectable I2t or I4t curve shaping
 - c. Programmable short-time setting
 - d. Programmable short-time delay with selectable flat or I2t curve shaping, and zone selective interlocking
 - e. Programmable instantaneous setting
 - f. Programmable ground fault setting trip or ground fault setting alarm
 - g. Programmable ground fault delay with selectable flat or I2t curve shaping and zone selective interlocking
18. The trip unit shall offer a three-event trip log that will store the trip data, and shall time and date stamp the event.
19. The trip unit shall offer information on the circuit breaker's health. The data available shall include total number of all Instantaneous and Short Delay trips seen by the circuit breaker, an additional count of all the overloads and ground fault trips seen by the circuit breaker, an operation counter, a time stamp of the last breaker operation, and the maximum temperature seen by the trip unit. All these data points will be stored in non-volatile memory and available for remote communications.

2.8. CENTRAL DISPLAY UNIT

- A. Where indicated on the drawings, provide a central display unit capable of displaying information and data from trip units specified above.

2.9. MISCELLANEOUS DEVICES

- A. Key interlocks shall be provided as indicated on the drawings. These interlocks shall keep the circuit breakers trip-free when actuated.
- B. Each section of the switchgear shall be provided with a space heater. Power for the heaters shall be obtained from a source as indicated on drawings. Supply voltage shall be 120 volts AC.
- C. Fused control power transformers shall be provided as indicated on the drawings or as required for proper operation of the equipment. A manual disconnect shall be provided ahead of the primary fuses.

2.11 OWNER METERING

- A. Furnish metering per section 26 27 13.

SECTION 26 24 15 - METAL-ENCLOSED DRAWOUT LOW VOLTAGE SWITCHGEAR**2.13. ENCLOSURES****A . NEMA 1 Enclosure**

1. Switchgear shall be enclosed in an outdoor walk-in NEMA 3R enclosure conforming to all applicable requirements of UL. The enclosure shall have a roof sloping toward the rear. Outer sections shall be the same widths as indoor structures except the end sections of a walk-in enclosure shall be wider than the inner sections to permit opening the inner door. Each end of the outdoor structure shall have an end trim. Front aisle depth for walk-in structures shall be 42 inches, minimum.
2. The enclosure shall be provided with rear hinged padlockable doors with wind stops for each section. Aisle doors shall be supplied with provisions for padlocking. A steel floor shall be provided in walk-in aisle space. Steel floor plates shall be provided in the rear cable compartment. An anti-skid floor strip shall be provided in the aisle. Ventilating openings shall be provided complete with replaceable fiberglass air filters which are removable from the exterior of the enclosure. Provide necessary space heaters thermostatically controlled for breaker, bus and cable compartments of adequate wattage to prevent the accumulation of moisture within the compartments.
3. Provide panic door hardware on aisle doors at each end of the line-up. External padlocking of the aisle doors shall not prevent operation of the panic hardware from the interior of the enclosure. The construction of the enclosure shall be modular so future sections can be added without affecting NEMA 3R integrity. Provide interior aisle fluorescent lights, 3- way switches and GFI protected receptacles.
4. The enclosure shall be provided with undercoating applied to all members in contact with the foundation surface to retard corrosion.
5. Power for the space heaters, lights and receptacles shall be obtained from a source as indicated on drawings. Supply voltage shall be 120 volts ac. An overhead circuit breaker lifter shall be provided in the aisle of the enclosure.
6. Each shipping section shall be shipped completely assembled.

2.14 NAMEPLATES

A. Engraved nameplates, mounted on the face of the assembly, shall be furnished for all main and feeder circuits as indicated on the drawings. Nameplates shall be laminated plastic, black characters on white background, and secured with screws. Characters shall be 3/16-inch high, minimum.

B. Furnish master nameplate giving switchgear designation, voltage ampere rating, short-circuit rating, and manufacturer's name.

SECTION 25 24 15 - METAL-ENCLOSED DRAWOUT LOW VOLTAGE SWITCHGEAR

C. Control components mounted within the assembly, such as fuse blocks, relays, pushbuttons, switches, etc., shall be suitably marked for identification corresponding to appropriate designations on manufacturer's drawings.

D. Lines shorter than one section should include painted on or plastic screwed on mimic bus.

2.15 FINISH

A. All exterior and interior steel surfaces of the switchgear shall be properly cleaned and provided with a rust-inhibiting phosphatized coating. Color and finish of the switchgear shall be ANSI 61.

2.16. ACCESSORIES

A. Provide a mechanical means of lifting breakers and remote racking mechanism for safety.

PART 3 EXECUTION**3.1. FACTORY TESTING**

A. The switchgear shall be completely assembled, wired, adjusted and tested at the factory. After assembly, the complete switchgear shall be tested to ensure the accuracy of the wiring and the functioning of all equipment. The main bus system shall be given a dielectric test of 2200 volts for one minute between live parts and ground and between opposite polarities.

B. The wiring and control circuits shall be given a dielectric test of 1500 volts for one minute, or 1800 volts for one second, between live parts and ground, in accordance with ANSI C37.20.1.

C. A certified test report of all standard production tests shall be shipped with each assembly.

3.2. FIELD QUALITY CONTROL

A. Provide the services of a qualified factory-trained manufacturer's representative to assist the Contractor in installation and start-up of the equipment specified under this section. The manufacturer's representative shall provide technical direction and assistance to the contractor in general assembly of the equipment, connections and adjustments, and testing of the assembly and components contained therein.

B. The Contractor shall provide three (3) copies of the manufacturer's field startup report.

3.3. MANUFACTURING CERTIFICATION

A. A qualified factory-trained manufacturer's representative shall certify in writing that the equipment has been installed, adjusted and tested in accordance with the manufacturer's recommendations.

SECTION 26 24 15 - METAL-ENCLOSED DRAWOUT LOW VOLTAGE SWITCHGEAR

B. The Contractor shall provide three (3) copies of the manufacturer's representative's certification before final payment.

3.5 INSTALLATION

A. The Contractors shall install all equipment per the manufacturer's recommendations and the contract drawings.

B. All necessary hardware to secure the assembly in place shall be provided by the Contractor.

C. The equipment shall be installed and checked in accordance with the manufacturer's recommendations. This shall include but not limited to:

1. Checking to ensure that the pad location is level to within 0.125 inches per three foot of distance in any direction.
2. Checking to ensure that all bus bars are torqued to the manufacturer's recommendations.
3. Assembling all shipping sections, removing all shipping braces and connecting all shipping split mechanical and electrical connections.
4. Securing assemblies to foundation or floor channels.
5. Measuring and recording Megger readings phase-to-phase, phase-to- ground, and neutral-to-ground (four wire systems only).

D. Inspecting and installing all circuit breakers in their proper compartments.

-END OF SECTION-

SECTION 26 24 16 - PANELBOARDS**Part 1 - General**

Provide panelboards consisting of an assembly of branch circuit switching and protective devices (circuit breakers) mounted inside a dead-front enclosure. Provide the number and size of these branch circuit devices as indicated by the circuiting, on the drawings, and in the schedules.

Part 2 - Products

1. All panelboards are to be of the same manufacturer. Panelboards shall be Square "D", Cutler Hammer or G.E.
2. Provide electrically-isolated, factory-installed neutral bus.
3. Provide separate ground bars complete with lugs or connectors on bar.
4. All bus shall be copper of 98% conductivity.
5. Provide panel doors equipped with chrome-plated locks and catches, all keyed alike. Provide two keys for each lock. Provide fronts with adjustable indicating trim clamps.
6. Provide thermal-magnetic circuit breakers which are fully rated and temperature rated for a 40 degrees C ambient. Breakers to be quick-make, quick-break type with trip indication shown by handle position other than ON or OFF and with a common trip on all multi-pole breakers.
7. 277/480 volts circuit breaker type panelboards are to be equivalent to Square D, type NQOD.
8. 120/208 volts circuit breaker type panelboards are to be equivalent to Square D, type NQOD.
9. Arrange bus in sequence or distribute phasing so that multi-pole circuit breakers can replace any group of single circuit breakers of the same size.
10. Terminal lugs are to be bolted type, labeled for copper conductors.

Part 3 - Execution

1. Ground, separate ground bars to panel boxes and to the main service entrance ground bus with a code-sized grounding conductor installed in the same conduit as the phase and neutral conductors.
2. Install all circuits using a common neutral in accordance with the latest edition of the National Electrical Code. Balance all circuits to achieve not greater than 10% unbalanced neutral current in panel feeders.
3. Provide typed directory cards under plastic on the doors of lighting and branch circuit panelboards

SECTION 26 24 16 - PANELBOARDS

4. Directories shall dictate devices being served including space numbers or space names in which devices or fixtures are located. Space names and numbers shall match the graphics installed.
5. Panel boards shall be labeled with a plastic laminated nameplate which identifies the panel by name. Labels shall be attached to the panel with screws or rivets. Glue is not acceptable.
6. From each flush-mounted panelboard, stub a minimum of two 1" empty conduits into area above ceilings.
7. Where flush mounted, the fire integrity of the wall in which it is installed must be maintained.
8. Plug all knockouts removed and not utilized.
9. All panelboards shall be phased identically throughout the building.

-END OF SECTION-

SECTION 26 24 19 - MOTOR CONTROL CENTERS**Part 1 – General****1.01 Scope**

All motor control centers shall be equipped with hand-off-automatic switches. Hand position being manually controlled and automatic position being computer controlled. Auxiliary contacts shall be available for monitoring condition of status by the University's centralized BSC. Questions are to be directed to the Plant Engineer or designee at 322-2621, Bryan Building.

Part 2 – Products**2.1 Manufacturers**

1. Square D, General Electric or Cutler Hammer.

Part 3 – Execution**3.01 Auxiliary contacts**

1. Wired to terminal blocks located in a separate section of the Motor Control Center. Terminals shall be appropriately identified for connecting to the BSC.
2. Each bucket of MCC should have individual control voltage
3. Each bucket shall be individually labeled.

-END OF SECTION-

SECTION 26 27 13 - ELECTRICAL METERING**Part 1 - General**

This specification covers the general meter, recorder and installation for all new construction and remodeling work as indicated by the Project Manager.

This installation shall be capable of operating continuously in both wet and dry location as per NEMA 4 standard.

Part 2 - Products

2.1 Meter shall be CT class or General Electric kV 2C kWh meter with demand, pulse monitoring capabilities and shall be installed on the primary feeder. Form - 9S or 9Z 3 stator for 3 phase, 4 wire wye service 120 volt w/form 9S w/kyz, optocom port. Form45S 2 stator for 1, 2, 3, phase 3 wire service, w/kyz optocom port. All meters shall be programmable demand register type and have shorting test blocks.

2.2 Electrical Meter and MuNet card to be provided by University.

2.3 Socket - Shall be Milbank or General Electric.

1. 13 terminals for 9S or 9Z meter.
2. 8 terminals (5s) for the 45S meter with isolation switches to short meter for service design rating.

2.4 Block - Arc and track resistant.

2.5 P.T. and C.T.'s - Size and voltage as required by multi-tap CT and PT size (max rating) and voltage approved by direct metering coordinator or designee.

Part 3 - Execution

On all meter connection, pertinent information shall be forwarded to Plant Engineer or Direct Metering Coordinator for review and approval before project is started.

- END OF SECTION -

SECTION 26 27 26 - WIRING DEVICES**Part 1 - General**

Provide switches, receptacles and other wiring devices as indicated on drawings.

Part 2 - Products**2.1 Lightning Arrestors**

1. Where lightning arrestors are required provide UL rated type.
2. All lightning arrestors in the substation will be made of porcelain.

2.2 Switches

1. Provide commercial grade, flush mounted, quiet operating AC type, with toggle operator, heat resistant plastic housing and self-grounding metal strap. Silver alloy contact. Rated 20A at 120/277V and capable of full capacity on tungsten or florescent lamp load. Design for side or back wiring with up to Number 10 wire.
2. Switches controlling lighting connected to the emergency power system shall be Red and should be of the illuminated-toggle type - illuminated when the switch is in the off position. Hubbell, Leviton or Pass and Seymour may be used.
3. Switches controlling lighting by way of low-voltage lighting control relays shall be 3-position, momentary-contact, center-off type to match the other switches.

2.3 Duplex Convenience Receptacles

1. Provide 3-pole commercial grade NEMA configuration with bronze contacts that accept plug with 2 parallel blades and 1 grounding blade. Rated 20 amperes at 125-volt electrical alternating current.
2. All devices connected to the emergency system shall be Red in color.
3. Dedicated electrical circuits provided for computers or other special equipment shall be Orange in color.
4. Receptacles to have separate equipment ground wire from receptacles to equipment ground bus in panelboards (do not use conduit).
5. Switching receptacles need to be top and bottom switchable.

2.4 Other Receptacles (Grounding Type)

1. Commercial grade - NEMA configuration indicated by circuit voltage and capacity shown on drawings.

SECTION 26 27 26 - WIRING DEVICES

2. When two or more switches or devices are shown in one location, mount under a common plate.

2.5 Outdoor Locations - Damp Locations

1. Each receptacle installed outdoors or in a damp location shall be corrosion resistant having all parts from stainless steel or nickel plated brass
2. Surface mounted receptacle boxes or junction boxes shall be stainless steel.
3. Recessed receptacle boxes may be plastic with approval of Project Manager.
4. Protect exterior switches and those in mechanical rooms which act as plenums by a cast aluminum metal plate with a fiber shield and spring loaded cover.
5. Protect exterior receptacles and those in mechanical rooms which act as plenums by a cast aluminum metal plate with a stainless steel spring loaded, gasketed, double flap lift cover to remain locked in either open or closed position.
6. When required, provide Ground-Fault Interrupters (GFI) which will interrupt leakage currents between 4-6 milli-amps having a maximum circuit current of 20 amperes. Employ feed through or non-feed through devices as indicated, or as required by NEC.

Part 3 - Execution

1. Mount switches vertically with the "on" position on top, unless noted or specified otherwise. Mount at 4'-0" above finished floor. Coordinate the location of switches to insure locations at the strike side of doors. Furnish and install an engraved faceplate legend for each switch that controls motors, equipment systems, etc., and for lights not located within sight of the controlling switch.
2. Unless otherwise noted, mount receptacle vertically with U-shaped ground position on bottom. Mount at 18" above finished floor, except where indicated otherwise.
3. Ground-Fault Interrupters - swab all conduits clear of moisture. Do not combine G.F.I. protected circuits with other circuits in same raceway. Provide a separate raceway for each G.F.I. protected circuit.

- END OF SECTION -

SECTION 26 32 13 - EMERGENCY STANDBY GENERATOR SYSTEMS**Part 1 – General****1.01 Scope**

This specification defines requirements for an emergency standby engine/generator system to be installed as per plans and specifications. System shall provide for completely automatic unattended operation, for the duration of any loss of normal utility power.

Part 2 – Products**2.1 Manufacturers**

1. Acceptable manufacturers include Caterpillar, Kohler, and Cummins.
2. Engine shall be full diesel, compression ignition, liquid-cooled, domestically manufactured and capable of producing the rated KW at a governed speed of 1800 rpm as specified under job site conditions. Engine to be equipped with electric starting, battery charging generator, electronic governor, fuel filters, oil filters, air cleaners, cooling system, and other equipment to provide a complete operable system. Selling distributor to be a factory authorized distributor of the diesel engine utilized in the standby engine generator system.
3. Generator package shall include stairs, platform, or any other components needed to provide full accessibility to the generator.

Part 3 – Execution

1. Entire unit shall be installed in accordance with manufacturers' recommendations.
2. Mounting: Complete engine/generator and all mounted accessories shall be assembled on a common channel steel base. Fuel oil lines and lube oil drain shall terminate in base. Lube oil drain line shall be brought out to beyond the base to facilitate changing of the oil. Flexible fuel line sections (18" long) to be installed between base and fuel lines. Heavy-duty, steel spring vibration isolators shall be installed between the base and mounting pad. Isolators shall be sized and located as recommended by generator manufacturer
3. Contractor shall provide the services of a factory-trained engineer for periodic job site visits during installation to ensure that the system is being installed in accordance with manufacturers' recommendations.
4. Complete engine/generator system shall be tested after installation to ensure that the engine/generator, automatic transfer switch, alarm annunciators, and all other equipment function in accordance with the specifications.

SECTION 26 32 13 - EMERGENCY STANDBY GENERATOR SYSTEMS

5. After installation, a 4-hour full load test shall be conducted by the distributor's engineer. This test shall be conducted using available building load, plus temporary load bank capacity so that full nameplate reading is utilized during test. Temporary load banks shall be furnished by generator distributor and connected by Division 26 contractor.
6. Contractor shall receive, store, uncrate and temporarily connect resistive type load(s) furnished by the generator supplier for full-load testing of the system. After completion of this testing, the Contractor shall disconnect, crate and load for shipment, the temporary load banks.
7. Ground the engine generator frame and enclosure using an equipment grounding conductor sized in accordance with the NEC. Do not ground generator neutral.

-END OF SECTION-

SECTION 26 33 05 - UNINTERUPPTIBLE POWER SYSTEM (UPS)**Part 1 – General****Part 2 – Products****2.2 Manufacturers**

1. APC, Leibert, Exide, or approved substitute.

Part 3 – Execution 3.01**Operating modes**

1. Normal Mode: The critical load shall be continuously supplied with regulated output power without battery backup power even under extreme brownout conditions (-20% of nominal). Line power shall be supplied to the Power Purification System and battery charger simultaneously maintaining a continuous float charge on the batteries.
2. Emergency Mode: Upon failure of the commercial AC power, battery power is transferred through the inverter to the Power Purification System. There shall be no interruption of regulated and conditioned power to the critical load upon failure of restoration of the commercial AC power.
3. Bypass Mode (Manual and Internal): If a problem occurs within the system due to an overload or internal failure, the manual bypass switch shall be activated to connect the commercial AC power to the Power Purification System. Thus, regulated and conditioned power is still supplied to the critical load until the problem is corrected. The bypass shall be internal to the UPS. System requiring external switchgear shall not be acceptable.

-END OF SECTION-

SECTION 26 35 13 - CAPACITORS**Part 1 - General**

- 1.1 Power-factor-correction capacitors shall be supplied for all motors 10hp and larger (including elevator motors).
- 1.2 Power Correction Capacitors select motors with the best available PF and add capacitors to motors as low as 10hp (less if on air compressors or other select applications). Power Factor Correction Capacitors are not compatible with VFD's.

Part 2 - Products

- 2.01 Capacitors to be complete with discharge resistors and internal HRC fusing. Capacitor enclosure shall be dustproof and of commercial-gauge, metal construction. Ratings of capacitors shall be sized to improve power factor on individual motor to 95%.

Part 3 - Execution

- 3.01 Capacitors shall be connected to load side of motor starter. Motor overload protection shall be adjusted to compensate for capacitor installation.

- END OF SECTION-

SECTION 2636 00 - AUTOMATIC TRANSFER SWITCH**Part 1 – General****Part 2 – Products****2.3 Manufacturers**

1. ASCO, Kohler, Zenith, Russelectric, or approved substitute.

Part 3 – Execution 3.01**Operating modes**

1. Switch shall be UL listed and CSA certified. It shall meet the voltage impulse withstand test in accordance with the proposed NEMA Standard 1CS1-109 and voltage surge withstand capability in accordance with ANSI/IEEE C37.90-1978. Switch(es) shall have ampere rating and voltage rating as shown on drawings.
2. Transfer switch(es) to be in NEMA-1 wall-mounted enclosures unless otherwise indicated. All control relays to be accessible from front of enclosure for maintenance and repair. Transfer mechanism to be electrically operated, mechanically held. Failure of the emergency source shall result in retransfer to the normal source. The transfer switch to be equipped with a manual operator to allow for manual transfer.
3. Engine starting contacts to be provided to start engine, should the voltage of the normal source drop below the preset value, after a time delay of 1-3 seconds to allow for momentary dips.
4. After restoration of normal power, transfer switch shall remain in emergency position for an adjustable period of 0-30 minutes (set for 15 minutes unless directed otherwise). After retransfer to normal, engine/generator to continue to run for an adjustable period of 0-20 minutes to allow for cool down. A voltage/frequency relay to be provided to prevent transfer to the emergency source until operating level is attained.
5. In addition to position indicating lamps, auxiliary contacts to be provided (one normally open, one normally closed).
6. Provide test switch to simulate a power failure, under load conditions.
7. Provide an automatic exerciser to operate the unit for a period of 30 minutes every 168 hours. During exercise period, transfer switch(es) shall not transfer to the emergency source.
8. Transfer switches used with ground-fault equipment, 4-wire systems to be 4-pole switched neutral or 3-pole with overlapping neutral contacts.
9. Switch(es) to be double throw actuated by a single operator, momentarily energized. Main contacts may be replaced without major disassembly. Transfer switch(es) with magnetic blow cuts to be provided on each pole.

SECTION 26 36 00 - AUTOMATIC TRANSFER SWITCH

10. Normal voltage sensing to be on 3-phase with pick-up at 95 percent and drop-out at 90 percent of normal voltage.
11. Interlocked molded case circuit breakers, contactors or transfer devices with dual solenoid operators are not acceptable.
12. ATS shall be equipped with a transparent protective cover allowing visual inspection of contacts while inhibiting inadvertent contact with energized components.

-END OF SECTION-

28 31 00 FIRE DETECTION AND ALARM**A. DESIGN REQUIREMENTS**

1. Specify compliance with the following current codes and standards.
 - a. State Building Code
 - b. Fire Marshal's Rules.
 - c. NFPA 70 (National Electrical Code)
 - d. NFPA 72 (National Fire Alarm Code)
 - e. NFPA 101 (Life Safety Code)
 2. Specify addressable systems installed in new buildings and in major remodels of existing buildings.
 - a. Voice systems are required by the Owner in all new construction and upgrades.
 - b. Discuss the basic system type with the Owner's Representative prior to design.
 3. On additions or remodels to existing systems, specify new equipment of the same manufacturer as existing equipment.
 4. For new fire alarm systems, specify equipment supplied by a factory-authorized Tennessee-based distributor with service personnel located within 50 miles of campus.
 - a. The following are approved manufacturers.
 - 1) Honeywell
 - 2) Johnson Controls (formerly Simplex Grinnel)
 5. Discuss the following items with the Owner's Representative and Environmental Health and Safety (EH&S) personnel during Schematic Design.
 - a. Location of fire department attack entrances.
 - b. Locations where information is available to emergency responders
 - c. Location of the fire alarm control panel and any annunciators
 - d. Basic system configuration, i.e. addressable, zone, voice
 - e. HVAC fan shutdown
 - f. Fire rated hinged door hold-open system and voltage
 - g. Fire rated coiling door operating system
 - h. Security/access system
 - i. Atrium detection system
 - j. Smoke control systems
 - k. Fire extinguishing system
 - l. Chemical spill alert system
 - m. Severe weather warning system
 - n. Elevators
 6. Fire alarm systems should typically be provided in all buildings with transmissions supervised by an FM Approved central station, proprietary system or constantly attended public fire service. Installation, operation, and maintenance of the alarm system should be in accordance with FM Global Property Loss Prevention Data Sheet 5-40, *Fire Alarm Systems*.
-

7. Provide smoke detectors in electrical transformer and switchgear rooms. The smoke detectors should be arranged to alarm to a constantly attended location.

B. CONSTRUCTION REQUIREMENTS

1. When the Contractor is working on operating fire alarm systems, specify that only circuit(s) involved in the work may be bypassed or disconnected and only during working hours.
 - a. Specify that the system must be operational at the end of the work day.

28 31 00 FIRE DETECTION AND ALARM

2. Specify the Contractor to cover detectors in construction areas during dust producing operations and to uncover detectors at the end of the work day.

C. CERTIFICATION TESTING:

1. Specify start up and certification testing done by a NICET level 2 or higher certified fire alarm technician, with the technician's name and certification number appearing on the certification documents.
2. Specify acceptance testing witnessed by an Owner's Fire Safety technician.
3. Specify testing and documentation in accordance with NFPA 72, or document as acceptable to the regulating authority.
4. Specify notification appliance circuits are measured and recorded on certification documents as follows.
 - a. In the alarm condition, the final system operating current and voltage at the fire alarm control panel and the voltage at end of line for each horn and strobe circuit.
 - 1) The maximum voltage drop must be less than 10%; correct if needed before certification.
 - b. The final system loop resistance of speaker circuits.
 - 1) The maximum loop resistance must be less than 20 ohms; correct if needed before certification.

D. DOCUMENTATION:

1. Specify one set of as-built fire alarm drawings per NFPA 72.
 - a. Provide an electronic record of the fire alarm system superimposed on the building background.
 - b. Show a wiring/connection diagram for fire alarm devices where new fire alarm hardware is connected into an existing system.
2. Specify submitting the completed and signed NFPA 72 certification documents to the Owner's Representative when the fire alarm is commissioned.
 - a. If acceptable to the regulating authority, specify submitting manufacturer's standard documentation instead of the NFPA Certificate

E. CONDUCTORS AND CABLES

1. Design the fire alarm system as a "power limited" system.
 - a. Specify wiring in 3/4 inch minimum raceway or in cable tray.
 - b. Specify cable tray if it can also be used for other services, such as telecom or security/access.
2. Specify minimum size # 18 AWG conductors, with larger sizes as needed.
3. Specify fire alarm cable is plenum rated, even when used in non-plenum areas or in raceway.
4. Specify wire and cable size and type as recommended by the fire alarm manufacturer.
5. Where cable shields and conductors are spliced, specify the splices are soldered and then insulated.
 - a. Wire connectors (wire nuts) are acceptable as insulation.

28 31 00 FIRE DETECTION AND ALARM

6. For risers and other splice points with more than three conductors, specify the use of junction boxes with terminal boards to eliminate soldering and allow easy disconnection for isolation.
 - a. Specify wire type, size, and manufacturer recommended by the equipment manufacturer.

F. GROUNDING AND BONDING

1. Specify shields isolated from ground, except at designated points.
2. For proper circuit monitoring, specify that fire alarm enclosures, boxes and raceways are grounded, even if they carry only power limited circuits.

G. IDENTIFICATION

1. Specify junction boxes are marked by painting them red and stenciling "FA" on the cover.
2. Specify that all fire alarm system conduit be red in color.

H. FIRE ALARM CONTROL PANEL

1. Locate in a non-public, low traffic area with an annunciator at the fire department attack entrance.
 - a. Discuss locations with the Owner's Representative and EH&S personnel.
2. Power Supplies
 - a. For the main power source, specify 120 VAC building power with emergency generator backup if available.
 - 1) For a secondary emergency power source, specify an internal battery pack.
 - 2) Do not specify an inverter backup.
 - b. In buildings without emergency generators, specify battery capacity as follows.
 - 1) 24 hours of standby plus 5 minutes in alarm with all notification appliances operating.
 - 2) Additional 50% spare capacity.
 - c. In buildings with emergency generators, specify battery capacity as follows.
 - 1) 4 hours of standby plus 5 minutes in alarm with all notification appliances operating.
 - 2) Additional 50% spare capacity.
 - d. For pre-action sprinkler systems, specify batteries with 90 hour standby capacity.
 - e. For new fire alarm control panels, specify oversize enclosures to have a minimum of 25% spare initiating zone or addressable point capacity and 25% spare notification appliance capacity.
 - f. Specify a dedicated circuit for each fire alarm control panel with the breaker installed with a breaker lock and plainly marked per NFPA 72.
 - g. Locate a convenience receptacle for service purposes within 3 feet of the fire alarm control panel.

28 31 00 FIRE DETECTION AND ALARM

3. Bypass Switches
 - a. Specify switches with an associated light emitting diode (LED) in the control panel programmed for the following bypass functions:
 - 1) Door holder release bypass
 - 2) Air handling unit shutdown bypass
 - 3) Alarm and supervisory signal bypass (city disconnect)
 - 4) Horn and strobe disable
 - 5) Elevator capture bypass
 - b. Specify that enabling any of the above bypass functions will result in a trouble signal.
 - 1) Specify that trouble signals cannot be bypassed.
4. Voice Systems
 - a. Specify voice systems for new buildings and major remodeling, and existing alarm upgrades.
 - 1) Discuss alternative system requirements with the Owner's Representative and EH&S personnel.
5. Communication with Campus Emergency Responders
 - a. Specify a stand-alone fire alarm system in each building that communicates with the BAS.
 - 1) Provide a programmable dry relay contact at the fire alarm control panel for each of the following functions.
 - a) General alarm (evacuation)
 - b) System trouble
 - c) Supervisory alarm (when used)
 - d) Chemical spill (when used)
 - e) Special alarms (when used)
 - b. Specify the fire alarm control panel is configured to provide contacts which open on alarm.
 - c. Specify a ¾" conduit with 18-2 shielded cables as required between the fire alarm control panel and the nearest building automation panel.
 - d. Specify the fire alarm control panel to have a digital alarm communicator installed.

28 31 00 FIRE DETECTION AND ALARM**I. INITIATING DEVICES AND CIRCUITS:**

1. General
 - a. Where zoned system detectors are located in elevator shafts, attics, crawl spaces and similar locations, specify a remote LED is installed in an accessible location.
 - 1) Specify a sign which indicates the detector type and location.
 - 2) If access to the detector is not apparent, specify directions are included on the sign.
 - 3) Specify black 1/4 inch upper case characters on a white background on or adjacent to the LED cover.
 - b. Except in special cases, do not specify remote LEDs for addressable systems.
2. Pull Stations
 - a. Locate at every entrance to a stair tower.
 - b. Wherever possible, locate to satisfy both NFPA 72 requirements and Fire Marshal's Rule 661- 5.659(100) 5.659(1) which requires a pull station within 75 feet of any classroom.
 - c. Specify single action type with centerline at 42 inches above finished floor.
 - 1) Discuss the use of double action type with the Owner's Representative and EH&S personnel.
 - 2) Specify pull station covers at child care areas and areas of potential vandalism.
3. Detectors
 - a. Specify photoelectric type smoke detectors for general use.
 - b. Do not specify ionization type smoke detectors without first consulting with the Owner's Representative.
 - c. Where the environment allows, specify electronic type heat detectors.
 - d. Specify rate of rise plus fixed heat detectors in laboratories.
 - e. In stair towers, locate the top detector accessible from a ladder placed on the top landing.
 - f. Before specifying, review atrium detection with the Owner's Representative and EH&S personnel.
 - g. Where possible, locate door release smoke detectors to satisfy both NFPA 72 requirements and corridor detector requirements.
 - h. Specify air-sampling duct detectors following NFPA 90A requirements.
 - 1) Locate upstream from humidification equipment.
 - 2) Do not specify air handling unit shut down hard wired to relay bases in detectors.
4. Sprinkler System Devices
 - a. Specify to install sprinkler valve tamper switches to initiate a "supervisory" condition.
 - b. Specify tamper switches are provided for post indicator, zone shut off and back flow prevention valves.

28 31 00 FIRE DETECTION AND ALARM

- c. Specify programming of water flow switches to sound the general alarm and provide time delays as necessary for stable system operation.
- d. Locate a transient voltage surge suppression device just inside the building on wiring to remote post indicator valve(s).

J. NOTIFICATION APPLIANCES AND CIRCUITS:

1. General

- a. Where ceiling height permits, locate the centerlines of wall mounted horns, speakers, strobes, and combination devices at 92 inches above finished floor.
 - 1) In all cases, locate the centerline of the device at least 6 inches below the ceiling.
- b. Provide adequate circuits for Audible and Visual devices.
 - 1) Give careful attention to wire sizing for voltage drop when specifying high current visual devices.
 - 2) High current devices may require specifying expansion power supplies.
- c. In an alarm condition, specify to measure and record the circuit current and the voltage at both the fire alarm control panel and at the end of line resistor.
 - 1) If the measured “as built” voltage drop exceeds 10%, make corrections before acceptance.
- d. Specify to measure the final loop resistance of speaker circuits at the fire alarm control panel.
 - 1) If the maximum resistance is more than 20 ohms, make corrections before acceptance.
- e. To quickly guide fire fighters to the fire alarm control panel or annunciator panel, locate an outside audio/visual signal device in a weatherproof box mounted on the building face near the attack entrance to sound a general alarm.
 - 1) Specify

2. Audible signal appliances

- a. Do not locate audible devices in stairwells.
- b. Specify fire resistant, moisture repellent, paper cone type speakers.
 - 1) Ceiling speakers are acceptable.
 - 2) Specify or approved equivalent.
- c. Specify strict compliance with NFPA 72 audibility requirements.
 - 1) Specify the standard temporal-three pattern for the general alarm evacuation signal.

3. Visual signal appliances

- a. Do not locate strobes or other visual devices in stairwells.
- b. Locate strobes per NFPA 72, NFPA 101 and ADA requirements.
- c. Specify synchronized strobes.

28 31 00 FIRE DETECTION AND ALARM**K. END OF LINE DEVICES:**

1. Install inside the last device on the circuit and mark with a 1/4" diameter blue dot on the outside of the device.
2. Show locations on as-built drawings.

L. ANNUNCIATORS

1. Specify a liquid crystal display (LCD) type located at fire department attack entrances as determined by discussion with the Owner's Representative and EH&S personnel.
 - a. Do not specify graphic annunciator panels.
2. Locate to prevent sunlight from washing out the LCD display.
3. Specify operating controls such as reset, acknowledge and smoke control are accessible by key only.

M. HVAC FAN SHUTDOWN:

1. Locate fan shutdowns where required by current code
2. Where the fire alarm system is addressable, specify HVAC fan shutdown using addressable relay modules.

N. FIRE-RATED HINGED DOORS

1. Where fire rated doors are held open and released when in alarm, specify electromagnetic door holders or closer/holders.
 - a. Where there is a wall to mount a door holders, specify equivalent or approved
 - b. Where there is no wall to mount door hold opens specify LCN 4040 SE series closer/holders
 - c. Where doors are held open in multiple positions with a swing free arm specify LCN 4310MW closer/holders.

O. Specify 24 VDC or 120 VAC as determined by discussion with the Owner's Representative. FIRE RATED COILING DOORS

1. For coiling door systems, obtain approval from the Owner's Representative before specifying.
 - a. Carefully review control and operational power.
 - b. Specify an approved door operator that powers the door both down and up.
 - 1) Do not specify manual door operation unless approved by the Owner's Representative.
2. Specify fire alarm system detectors with auxiliary contacts or fire alarm control panel operated relays on both sides of the door, regardless of ceiling height, to release the door in the event of a fire.
 - a. Specify the sequence of operation as follows.
 - 1) If either door detector alarms, the building fire alarm system will sound a general alarm and the door will close.

28 31 00 FIRE DETECTION AND ALARM

- 2) If a detector elsewhere in the building alarms, it will sound a general alarm, but the doors will not close.

P. ELEVATORS

1. Specify relay(s) for recall, shunt trip, and fire fighter's visual indicator as required by ASME A17.1 and NFPA 72.
 - a. Specify means to monitor shunt trip power.
 - b. Locate relays and monitor modules in the elevator equipment room for connection to elevator equipment.
2. Elevator recall and/or shunt trip functions
 - a. In new addressable systems, specify to initiate from the fire alarm control panel; no exceptions.
 - b. In existing buildings, see the Owner's Representative for fire alarm system capabilities and details.
3. For smoke and heat detectors at the top of the hoistway, provide access from the top of the car.
 - a. For non-addressable alarm systems, locate a remote indicator at the top floor elevator lobby.
4. Specify addressable relays for recall.
 - a. Do not specify base relays in the detector.
 - b. For non-addressable alarm systems, discuss alternatives with the owner's Representative and EH&S personnel.
5. Where the fire alarm system is addressable, specify elevator shutdown using addressable relay modules.

- END OF SECTION -

SECTION 31 11 00 - CLEARING AND GRUBBING

Part 1 – General

1.01 Work Included

A. Clearing, grubbing, removal and disposal of vegetation, rocks, roots and debris within the limits of the work except objects designated on the drawings to remain.

B. Preserve from injury or defacement all vegetation and objects to remain.

1.02 Related Work

A. Section 02 41 13: Site Demolition

B. Section 31 23 00: Site Excavation

C. Section 31 23 23: Backfilling and Finish Grading

1.03 Limits Of Work

A. Construction area established by drawings.

B. Designated stockpiles of construction material other than borrow material.

1.04 Protection

A. Protect living trees in accordance with Section 32 01 90.33

B. Protect benchmarks and existing structures, roads, sidewalks, paving and curbs against damage from vehicular or foot traffic.

C. Maintain designated temporary roadways, walkways and detours, for vehicular and pedestrian traffic.

Part 2 - Products

2.01 Materials

A. Fence shall be chain link fence with steel posts.

Barricades shall be in accordance with local governing authority.

SECTION 31 11 00 - CLEARING AND GRUBBING**Part 3 - Execution****3.01 Preparation**

A. Maintain bench marks, monuments and other reference points. Re-establish if disturbed or destroyed at no cost to Owner.

3.02 Clearing And Grubbing

A. Clear and grub areas required for access to site and execution of the work. Remove all stumps and roots within limits of grubbing to the depths below.

1. Footings – 18 inches
2. Walks – 12 inches
3. Roads – 18 inches
4. Parking areas – 12 inches
5. Lawn areas – 8 inches
6. Fills – 12 inches
7. In the case of footings, roads, walks, or other construction on fills, the greater depth shall apply.

B. Grub, borrow pit and stockpile of all objectionable material. Strip overburden before placing material in stockpile areas.

C. Perform clearing and grubbing well in advance of construction or material removal activities.

3.03 Pruning

A. If trees, shrubs or other perennial growth are damaged in the course of Work of this Contract, contact the Owner immediately. Remedial measures shall be coordinated with the Owner.

3.04 Debris Removal

A. Promptly remove cleared debris from site.

B. Obtain permission from applicable regulatory authority for disposal of debris to waste disposal site.

C. Do not burn or bury materials on site.

SECTION 31 11 00 - CLEARING AND GRUBBING

3.05 Repairs

A. Should utilities to remain, or other physical property be damaged by work of this Section, repair damage.

B Backfill all excavations opened as a result of the work of this Section with the type of fill specified in Section 31 23 00 for the individual locations.

- END OF SECTION -

SECTION 31 22 19 - FINISH GRADING**Part 1 – General**

1.01 Refer to Landscape Strategic Plan (Appendix C) for additional details and specifications on soils, grading, plantings, etc.

1.02 Scope

A. Place, spread and shape topsoil to achieve the finished contour elevations indicated by the drawings.

1.03 Related Work

A. Section 32 01 90.33: Tree and Shrub Preservation

B. Section 32 90 00: Planting

1.04 Protection

A. Prevent damage to existing trees to remain, bench marks, pavement, and utility lines. Correct damage at no cost to the Owner.

1.05 Quality Assurance

A. The Owner shall employ a qualified testing laboratory to observe this work and make tests required.

B. Have topsoil tested and approved before it is moved to the project site.

Part 2 – Products**2.01 Materials**

A. Provide topsoil equivalent to Maury silt loam: 12-27% clay, 20-50% sand, 40-68% permeability 2-6 inches per hour, low shrink-swell potential, pH 6.0-7.0. Topsoil to have a minimum 2% organic material.

B. Topsoil shall be tested for sand, silt and clay percentages, organic content, pH and nutrient content by:

AGRI Systems of Texas, Inc.
15511 Baldswalle
Tomball, TX 77375
(713) 376-4412

Or

A & L Agricultural Laboratory
411 North Third Street
Memphis, TN 38105
(901) 527-2780
(901) 526-1031 (fax)

SECTION 31 22 00 - FINISH GRADING

A. Topsoil shall be free of live Bermuda grass roots, stones and roots over 1-inch diameter and other foreign matter. Use topsoil stockpiled on site if conforming to these requirements. If inadequate topsoil exists on site, contractor will be responsible for providing additional topsoil.

B. Refer to Planting Specifications 32 90 00 for required organic and inorganic topsoil amendments.

Part 3 – Execution**3.01 Placing Topsoil**

A. Place topsoil in areas where seeding, sodding, and planting is to be performed. Place to the following minimum depths, up to finished grade elevations:

1. 12 inches for seeded or sodded areas or groundcover beds.
2. 24 inches for shrub beds.
3. 36 inches for tree pits.

B. Use topsoil in relatively dry state. Place during dry weather:

C. Fine grade topsoil eliminating rough and low areas to ensure positive drainage. Maintain levels, profiles and contours indicated on the grading plan.

D. Remove stone, roots, grass, weeds, debris and other foreign material while spreading.

E. Manually spread topsoil around trees and plants to prevent damage which maybe caused by grading equipment.

F. Lightly compact placed topsoil.

3.05 Clean-Up

A. Upon completion of work of this Section, clean up and leave area free of debris, excess material, and equipment.

B. Any excess earth shall be removed from the area by the contractor, who shall properly dispose of the material.

- END OF SECTION -

SECTION 31 23 00 - EXCAVATION AND FILL**Part 1 – General****1.01 Scope**

- A. Excavation and fill for:
 - 1. Building pads and foundations.
 - 2. Embankment areas.
 - 3. Waterways and ditches (including inlet structures and outlet ditches)

1.02 Related Work

- A. Section 01 45 29 Testing Laboratory Services
- B. Section 31 11 00 Clearing and Grubbing
- C. Section 31 22 19.13 Spreading and Grading Topsoil

1.03 Definitions

- A. Excavation consists of removal of material encountered to subgrade elevations indicated and subsequent disposal of materials removed.
- B. Unauthorized excavation consists of removal of materials beyond indicated subgrade elevations or dimensions without specific direction of Architect. Unauthorized excavation, as well as remedial work directed by Architect, shall be at Contractor's expense.
- C. Additional Excavation: When excavation has reached required subgrade elevations, notify Geotechnical Engineer, who will make an inspection of conditions. If Geotechnical Engineer determines that bearing materials at required subgrade elevations are unsuitable, continue excavation until suitable bearing materials are encountered. The Contract Sum maybe adjusted by an appropriate Contract Modification.
- D. Subgrade: The undisturbed earth or the compacted soil immediately below granular sub-base, drainage fill, or topsoil materials.
- E. Structure: Buildings, foundations, slabs, tanks, curbs or other man-made stationary features occurring above or below ground surfaces.

1.06 Quality Assurance

- A. Codes and Standards: Perform excavation work in compliance with applicable requirements of authorities having jurisdiction.
- B. Testing and Inspection Service: Owner will employ and pay qualified independent geotechnical testing and inspection laboratories to perform soil testing and inspection service during earth operations.

SECTION 31 23 00 - EXCAVATION AND FILL**1.07 Existing Conditions**

- A. Known underground, surface and aerial utility lines, and buried objects as indicated on the Drawings.
- B. Do not interrupt existing utilities service to facilities occupied and used by the Owner or others, except when permitted in writing, by Owner's Representative and then only after temporary utility services have been provided.

1.08 Protection

- A. Protect trees, shrubs and lawns, rock outcroppings and other features remaining as part of final landscaping, as directed by University Landscape Architect.
- B. Protect benchmarks, existing structures, fences, roads, sidewalks, paving, and curbs against damage from equipment and vehicular traffic.
- C. Protect aerial, surface, or underground utility lines and appurtenances which are to remain.
- D. Repair damages.
- E. Erosion control must be maintained. Refer to notes on demolition, fencing and/or grading plans.

1.09 Environmental Requirements

- A. Provide for surface drainage during the period of construction in a manner to avoid creating a nuisance to adjacent areas. Keep excavation free of water during the entire progress of the work, regardless of the case, source, or nature of the water.
- B. Trees shall be left undisturbed, as shown on drawings.

1.10 Sediment and Erosion Control

- A. Protect newly graded areas from erosion. Where necessary, temporarily seed disturbed areas with annual rye grass at a rate of 4 lbs/1000 sq. ft. If seeding is necessary in summer months, contact the Owner's Representative for an approved seeding application.
- B. Repair settlement and erosion which occurs prior to acceptance of work.
- C. Temporary Ditch Checks: Place two unbroken straw bales in a "V" formation, with open end upstream in ditches as directed by Owner Representative. Place ditch check at 50 foot intervals for ditches, with slopes between 1.0 percent and 3.0 percent. For ditches steeper than 3.0 percent, place at 25 foot intervals and stake each bale firmly with a 2"x4" wood stake or other means as directed by the Owner's Representative.
- D. Leave straw bale ditch checks in place throughout construction except when ditches are fine graded, and seeded or sodded.
- E. Perform periodic maintenance on ditch checks to remove sediment and replace straw bales as necessary so as not to inhibit flow or runoff.

SECTION 31 23 00 - EXCAVATION AND FILL**1.11 Reference Standards**

- A. Determine soil's maximum dry density and optimum moisture in accordance with ASTM D698.
- B. Rock borings or soundings, if provided, are:
 - 1. For information purposes only.
 - 2. No guarantee of existing conditions.
 - 3. No substitute for investigations deemed necessary by Contractor.

Part 2 – Products**2.01 Soil Materials**

- A. Satisfactory soil materials are defined as those complying with ASTM D2487 soil classification groups, GW, GP, GM, SM, SW, and SP, and approved by the testing agency.
- B. Unsatisfactory soil materials are defined as those complying with ASTM D2387 soil classifications groups GC, SC, ML, MH, CL, CH, OL, OH, and PT, or those rejected by the testing agency.
- C. Drainage Fill: Washed, evenly graded mixture or crushed stone, or crushed or uncrushed gravel, with 100% passing with a 1-1/2 inch sieve and not more than 5% passing a No. 4 sieve.
- D. Backfill and Fill Materials: Satisfactory soil materials free of clay, rock or gravel larger than 2 inches in any dimension, debris, waste, frozen materials, vegetation and other deleterious matter. Fill material should have a liquid limit less than 38 and a plasticity index more than 4 but less than 18.
- E. Topsoil: Excavated material, from construction site if approved by University Landscape Architect, graded free of roots, subsoil, debris, large weeds, toxic substances, and rocks greater than 1 inch. If topsoil from construction site is unavailable or unsuitable, topsoil as specified in Finish Grading Topsoil (Section 31 22 19) shall be brought to site.

Part 3 – Execution**3.01 General Site Excavation**

- A. All excavation is unclassified.
- B. Do not excavate wet subsoil materials.
- C. Excavate subsoil required to allow placement of compacted backfill under paving and site structures, and to accommodate construction operations.
- D. Machine slope banks to angle of repose or less until shored.
- E. Removed lumped subsoil, boulders and rock.

SECTION 31 23 00 - EXCAVATION AND FILL

- F. Completely remove stumps, roots over 1 inch in diameter and similar on-grade and below-grade obstructions within the area to be covered by new construction and for a distance of 10 feet beyond area in all directions. In other areas disturbed by grading, remove such obstructions to a depth of 2 feet below subgrade.
- G. Correct unauthorized excavation, including areas over-excavated by error, at no extra cost to the Owner.
- H. Stockpile excavated material in designated area on site to a depth not exceeding 8 feet and protect from erosion. Remove excess material not being reused from site. Stockpile areas not to be identified during a pre-construction meeting of the jobsite.

If existing basements, cellars, cisterns, wells, septic tanks, drain fields, cesspools, catch basins, sink holes, manholes and similar items are encountered, remove to solid subgrade and break up masonry and/or concrete bottoms so that no pieces remain over 12 inches in the longest dimension.

3.02 Removal of Topsoil

- A. Remove topsoil of horticultural value from areas to be excavated and regarded, and stockpile in designated area.
- B. Do not permit topsoil to be mixed with subsoil.
- C. Do not strip topsoil when wet.

3.03 Stability of Excavations

- A. General: Comply with local codes, ordinances, and requirements of agencies having jurisdiction.
- B. Slope sides of excavations to comply with local codes, ordinances, and requirements of agencies having jurisdiction. Shore and brace where sloping is not possible because of space restrictions or stability of material excavated. Maintain sides and slopes of excavations in safe condition until completion of backfilling.

3.04 Dewatering

- A. Prevent surface water and subsurface or groundwater from flowing into excavations and from flooding project site and surrounding area.
1. Do not allow water to accumulate in excavations. Remove water to prevent softening of foundation bottoms, undercutting footing, and soil changes detrimental to stability of subgrades and foundations. Provide and maintain pumps, well points, sumps, suction and discharge lines, and other dewatering system components necessary to convey water away from excavations.
 2. Establish and maintain temporary drainage ditches and other diversions outside excavation limits to convey rain water and water removed from excavations to collecting or runoff areas. Do not use trench excavations as temporary drainage ditches

SECTION 31 23 00 - EXCAVATION AND FILL**3.05 Excavation For Structures**

A. Conform to elevations and dimensions shown within a tolerance of plus or minus 0.10 foot, and extending a sufficient distance from footings and foundations to permit placing and removal of concrete formwork, installation of services, and other construction and for inspection.

B. Excavations for grade beams and foundations: Do not disturb bottom of excavation. Excavate by hand to final grade just before concrete reinforcement is place. Trim bottoms to required lines and grades to leave solid base to receive other work.

3.06 Cold Weather Protection

A. Protect excavation bottoms against freezing when atmospheric temperature is less than 35 degrees F.

3.07 Preparation Of Natural Ground

A. Proof-roll areas to be covered by construction with loaded rubber-tired dump truck having a single axle weight of approximately 30,000 lbs., or similar equipment. Owner's Representative is to identify any unstable areas.

B. Unsuitable subgrades identified by the testing agency may attempt to be stabilized by scarifying, aerating and recompaction, if these procedures are approved by the geotechnical representative. Scarify at an effective depth of 12 inches and recompact.

C. If, after scarification, aeration and recompaction operations are completed, any exposed subgrades are determined by the testing agency as incapable of being stabilized in-place; perform remedial work as specified below.

3.07 Remedial Work

A. If, after scarification, aeration and recompaction operations specified above are completed, any exposed subgrades are determined by the testing agency as incapable of being stabilized in-place, undercut to a depth identified by the testing agency and backfill.

1. Notify the Architect to obtain approval prior to beginning undercutting operations.
2. Keep records of material quantities removed and replace as specified in Division 1 and have materials verified by the testing agency.

B. If required, excavate shallow temporary drainage ditches to facilitate removal of excess moisture from subgrade areas.

3.08 Backfill and Fill

A. General: Place soil material in layers to required subgrade elevations, for each area classification listed below, using materials specified in Part 2 of this Section.

1. In crawlspace, use drainage fill material.

SECTION 31 23 00 - EXCAVATION AND FILL

2. Inspection, testing, approval, and recording locations of underground utilities have been performed and recorded.
3. Backfill trenches with concrete where trench excavations pass within 18 inches of column or wall piers and that are carried below bottom of such footings or that pass under wall footings. Place concrete to level of bottom of adjacent piers.

B. Backfill excavations as promptly as work permits, but not until completion of the following:

1. Acceptance of construction below finish grade including, where acceptable, damproofing, waterproofing, and perimeter insulation.
2. Inspection, testing, approval, and recording locations of underground utilities have been performed and recorded.
3. Removal of concrete formwork.
4. Removal of shoring and bracing, and backfilling of voids with satisfactory materials.
5. Removal of trash and debris from excavation.
6. Permanent or temporary horizontal bracing is in place on horizontally supported walls.

3.09 Placement and Compaction

A. Ground Surface Preparation: Remove vegetation debris, unsatisfactory soil materials, obstructions, and deleterious materials from ground surface prior to placement of fills. Plow strip, or break up sloped surfaces steeper than 1 vertical to 4 horizontal so that fill material will bond with existing surface.

1. When existing ground surface has a density less than that specified under "Compaction" for particular area classification break up ground surface, pulverize, moisture-condition to optimum moisture content, and compact to required depth and percentage of maximum density.

B. Place backfill and fill materials in layers not more than 8 inches in loose depth for material compacted by heavy compaction equipment.

C. Edges of compacted fill should extend at least 10 feet beyond the building prior to sloping.

D. Before compaction, moisten or aerate each layer as necessary to be within a range 1% below or 3% above optimum moisture content. Compact each layer to required percentage of maximum dry density or relative dry density for each area classification. Do not place backfill or fill material on surfaces that are muddy, frozen, or contain frost or ice.

E. Place backfill and fill materials evenly adjacent to structures, piping, or conduit to required elevations. Prevent wedging action of backfill against structures or displacement of piping or conduit by carrying material uniformly around structure, piping, or conduit to approximately same elevation in each lift.

SECTION 31 23 00 - EXCAVATION AND FILL

F. Control soil and fill compaction, providing minimum percentage of density specified for each area classification indicated below. Correct improperly compacted areas or lifts as directed by Architect if soil density tests indicate inadequate compaction.

1. Percentage of Maximum Density Requirements: Compact soil to not less than the following percentages of maximum density, in accordance with ASTM D 698:
 - a. Under structures, building slabs and steps, and pavements, compact top 8 inches of subgrade and each layer of backfill or fill material at 95% maximum density.
2. Moisture Control: Where subgrade or layer of fill material must be moisture conditioned before compaction, uniformly apply water to surface of subgrade or layer of soil material. Apply water in minimum quantity as necessary to prevent free water from appearing on surface during or subsequent to compaction operations.
 - a. Remove and replace, or scarify and air dry, soil material that is too wet to permit compaction to specified density.
 - b. Stockpile or spread soil material that has been removed because it is too wet to permit compaction. Assist drying by disking, harrowing, or pulverizing until moisture content is reduced to a satisfactory value.

3.10 Grading

A. General: Uniformly grade areas within limits of grading under this section, including adjacent transition areas. Smooth finished surface within specified tolerances, compact with uniform levels or slopes between points where elevations are indicated or between such points and existing grades.

B. Grading Outside Building Lines: Grade areas adjacent to building lines to drain away from structures and to prevent ponding. Finish surfaces free from irregular surface changes and as follows:

C. Compaction: After grading, compact subgrade surfaces to the depth and indicated percentage of maximum or relative density for each area classification.

3.11 Field Quality Control

- A. Quality Control Testing during Construction: Allow testing service to inspect and approve each subgrade and fill layer before further backfill or construction work is performed.
 1. Perform field density tests in accordance with ASTM D 698.
 - a. Field density tests may also be performed by the nuclear method in accordance with ASTM D 2922, providing that calibration curves are periodically checked and adjusted to correlate to tests performed using ASTM D 1556. In conjunction with each density calibration check, the calibration curves furnished with the moisture gauges in accordance with ASTM D 3017.
 - b. If field tests are performed using nuclear methods, make calibration checks of both density and moisture gauges at beginning of work, on each different type of material encountered, and at intervals as directed by Architect.

SECTION 31 23 00 - EXCAVATION AND FILL

2. Foundation Wall Backfill: Perform at least two field density tests at locations and elevations as directed
3. If in opinion of Architect, based in testing service reports and inspection, subgrade or fills that have been placed are below specified density, perform additional compaction and testing until specified density is obtained.

3.12 Erosion Control

- A. Provide erosion control methods in accordance with requirements of authorities having jurisdiction.

3.13 Maintenance

- A. Protection of Graded Areas: Protect newly graded areas from traffic and erosion. Keep free of trash and debris.
- B. Repair and reestablish grades in settled, eroded, and rutted areas to specified tolerances.
- C. Reconditioning Compacted Areas: Where completed compacted areas are disturbed by subsequent construction, operations or adverse weather, scarify surface, reshape, and compact to required density prior to further construction.

3.14. Disposal of Excess and Waste Materials

- A. Removal from Owner's Property: Remove waste materials, including unacceptable excavated material, trash, and debris, and manage it in accordance with outlined waste management requirements found in these guidelines and in the SBS (Appendix A).

- END OF SECTION -

SECTION 31 25 13 - EROSION CONTROL**Part 1 – General****1.01 Description**

A. This work shall consist of erosion control on all cut and fill operations, excavations, backfill, or other construction activities within the limits of the construction site, within any temporary or permanent easements, and within any borrow site used during the period of construction. The protection of these sites shall continue throughout the construction period. During flood seasons, protect the sites by sandbagging, the pumping of water, and any other means appropriate to restrain flooding. During dry weather, sprinkle the sites with water or use other means as necessary to provide dust control.

B. The temporary pollution control provisions contained herein shall be coordinated with the permanent erosion control features, to ensure economical, effective, and continuous erosion control throughout the construction and post construction period.

C. It is the intent of this section to provide a written plan to ensure Metro Stormwater Best Management Practices are followed. Since the Contractor is responsible for the construction means and methods which in turn are responsible for ensuring that construction does not harm the Waters of Tennessee, the Contractor is solely responsible for ensuring that the above mentioned laws and regulations are met.

Part 2 – Products**2.01 Temporary Seeding and Mulching**

A. Temporary seeding and mulching are measures consisting of seeding, mulching, fertilizing, and matting utilized to reduce erosion. All cut and fill slopes, including waste sites and borrow pits, shall be seeded when and where necessary to eliminate erosion.

2.02 Baled Hay or Straw Checks

A. Baled hay or straw erosion checks are temporary measures to control erosion and prevent siltation. Bales shall be either hay or straw containing 5 cubic feet or more of material.

B. Baled hay or straw checks shall be used where the existing ground slopes toward or away from the embankment along the toe of slopes, in ditches, or other areas where siltation erosion or water runoff is a problem.

2.03 Temporary Silt Fences

A. Silt fences are temporary measures utilizing woven wire or other approved material attached to posts with filter cloth composed of burlap, plastic filter fabric, etc. attached to the upstream side of the fence to retain the suspended silt particles in the runoff water. Installation shall comply with Metro Stormwater Best Management Practices TCP-13.

SECTION 31 25 13 - EROSION CONTROL**Part 3 – Execution****3.01 Project Review**

A. The project drawings show the minimum erosion and siltation control measures required for this job. If the Contractor desires to stockpile construction materials, stone, earth, etc., the location of same and protection thereof shall be outlined in an Erosion and Siltation Control Plan to be submitted to the ULA (University Landscape Architect) for review.

B. The Contractor shall submit a spill prevention plan to the ULA for review. The contents of this spill prevention plan shall depend on what types of chemicals, lubricants and fuels will be used and if these will be stored on site. As a minimum, if fuel, lubricants or other chemicals are stored on site, either temporarily in vehicular tanks or in skid or trailer mounted tanks, a plan shall be supplied which directs all employees of the Contractor in the proper procedures to be followed should a spill occur. For more complex chemical storage requirements, a more complex plan will be required.

3.02 Construction Requirements

A. The ULA has the authority to limit the surface area of erodible earth material exposed by clearing and grubbing, the surface of erodible earth material exposed by exaction, borrow and fill operations and to direct the Contractor to provide immediate permanent or temporary pollution control measures to prevent contamination of adjacent streams or other watercourses, lakes, ponds, or other water impoundment. Such work may involve the use of temporary mulches, mats, seeding or other control devices or methods as necessary to control erosion. Cut and fill slopes shall be seeded and mulched as the excavation proceeds to the extent directed by the ULA.

B. The Contractor shall be required to incorporate all permanent erosion control features into the project at the earliest practicable time as outlined in his accepted schedule. Temporary pollution control measures shall be used to correct conditions that develop during construction that were not foreseen during the preconstruction stage; that are needed prior to installation of permanent pollution control features; or that they are needed temporarily to control erosion that develops during normal construction practices, but are not associated with permanent control features on the project.

C. Where erosion is likely to be a problem, clearing and grubbing operations should be scheduled and performed so that grading operations and permanent erosion control measures can follow immediately thereafter if the project conditions permit. If not, erosion control measures may be required between successive construction stages. Under no conditions shall the surface area of erodible earth material exposed at one time by clearing and grubbing, exceed 150,000 square feet without approval of the ULA.

D. The ULA will limit the area of excavation, borrow, and embankment operations in progress commensurate with the Contractor's capability and progress in keeping the finish grading, mulching, seeding, and other such permanent pollution control measures current in accordance with the accepted schedule. Should seasonal limitations make such coordination unrealistic, temporary erosion control measures shall take immediately to the extent feasible and justified.

E. Under no conditions shall the amount of surface area or erodible earth material exposed at one time by excavation or fill within the project area exceed 150,000 square feet without approval of the ULA.

SECTION 31 25 13 - EROSION CONTROL

F. In the event of conflict between these requirements and pollution control laws, rules or regulations, or other federal, state, or local agencies, the more restrictive laws, rules, or regulation shall apply.

3.03 Construction of Structures

A. Temporary Seeding and Mulching: Seeding and mulching shall be performed in accordance with the Section 02480, Landscape Specifications.

B. Baled Hay or Straw Erosion Checks: Hay or straw erosion checks shall be embedded in the ground 4 to 6 inches to prevent water flowing under them. The bales shall also be anchored securely to the ground by wooden stakes driven through the bales into the ground. Bales may be removed after they have served their purpose, as determined by the ULA. The Contractor shall keep the checks in good condition by replacing broken or damaged bales immediately after damage occurs. Normal debris cleanout will be considered routine maintenance.

C. Temporary Silt Fences:

1. Temporary silt fences shall be placed on the natural ground, at the bottom of fill slopes, in ditches, or other areas where siltation is a problem. Silt fences are constructed of wire mesh fence with a covering of burlap or some other suitable material on the upper grade side of the fence and anchored into the soil.
2. The Contractor shall be required to maintain the silt fence in a satisfactory condition for the duration of the project or until its removal is requested by the owner's representative. The silt accumulation at the fence may be left in place and seeded, removed, etc., as directed by the owner's representative. The silt fence becomes the property of the Contractor whenever the fence is removed.

D. Under no circumstances will spent oil wastes be discharged anywhere on the site without the expressed written consent of the Tennessee Office of Water Management.

3.4 Maintenance

A. The temporary erosion control features installed by the Contractor shall be acceptably maintained by the Contractor until no longer needed or permanent erosion control methods are installed. Any materials removed shall become the property of the Contractor.

3.5 Erosion Control Outside Project Area

A. Temporary pollution control shall include construction work outside the project area where such work is necessary as a result of construction such as borrow pit operations, haul roads, and equipment storage sites.

- END OF SECTION -

SECTION 31 31 16 13 - TERMITE CONTROL**Part 1 - General**

In all new construction and major renovation projects, Designer should require preconstruction soil treatment for termite control. Effective subterranean termite control requires the establishment of an unbroken vertical and/or horizontal chemical barrier between wood in a facility and termite colonies in the soil. Treated areas should be posted with a written warning until they are covered. Prior to treatment, the Contractor should give Vanderbilt's Project Manager one week's notice so that a representative of Plant Operations may schedule random sampling of treated soil. The Treatment Contractor will be required to warrant his work for a period not less than five years and Bid documents should request a unit price for annual inspection for ten year period.

Part 2 - Products

Approved treatment emulsions are as follows:

1%	Dursban TC
1%	Demon TC
1%	Gold Crest Tribute
0.75%	Pryfon 6 Insecticide

Part 3 - Execution

1. For horizontal barriers, apply at the rate of 1 gallon per 10 SF if dirt fill is used. If fill material is washed gravel, apply at 1.5 gallons per 10 SF.
2. For vertical barriers, including foundation walls, expansion joints, plumbing traps or any slab penetration, apply at 4 gallons per 10 linear ft. per foot of fill depth to footing (example: a footing 3 ft. deep requires 12 gallons of emulsion per 10 linear feet.) Application should be by (1) rodding or (2) trenching and mixing emulsion with soil as it is being replaced in trench.
3. Where hollow masonry units are used in foundation walls, and where horizontal barrier application is not made prior to pouring of footing, treatment may be made through masonry voids to establish a chemical barrier at the top of footing. Apply at the rate of 2 gallons per 10 linear feet.
4. In crawl spaces, apply at 4 gallons per 10 linear feet per foot of 6 foot depth to footings of foundation walls, piers, supports or pipes.
5. Exterior foundation walls of both crawl spaces and slabs are to be treated after backfill is completed.

- END OF SECTION -

SECTION 32 01 90.33 - TREE AND SHRUB PRESERVATION**Part 1 – General****1.01 Scope**

- A. Protect living trees and shrubs not marked for removal and outside the construction area.
- B. Provide root protection trenching to avoid damaging trees and shrubs during grading operations within the root zone.
- C. Treat damaged trees and shrubs to prevent additional harm.
- D. Trim trees and shrubs to provide clearance for access and construction activities.

1.02 Related Work

- A. Section 02 41 13: Site Demolition
- B. Section 31 22 00: Grading
- C. Section 31 22 19.13: Spreading and Grading Topsoil

1.03 Quality Assurance

- A. Comply with Metro requirements for tree protection.
- B. Refer to tree protection notes on Demolition and Construction Plans.

Part 2 – Products

- A. Fencing shall be 6' tall chain link fencing wired to 8' steel poles.

Part 3 – Execution**3.01 Trimming Operation**

- A. The pre-construction trimming operation shall be completed by others and shall include only trees affected by construction:
 - 1. Trees to be trimmed will be designated as specified in the Site Plan and flagged in the field.
 - 2. A list of the trees to be trimmed and the prescribed tree care needed will be provided by the Owner.

SECTION 32 01 90.33 - TREE AND SHRUB PRESERVATION

3. Trimming shall consist of pruning to provide clearance for vehicular traffic, structures, equipment, tree protection fencing, line of sight, and trenching machines.

3.02 Root Protection Trenching

A. The root protection trenching operation shall be completed by the Contractor and shall consist of the following:

1. Where excavation, grade cutting, or tree removal is to occur within a tree root zone, make a clean cut, 3 feet deep minimum, between the designated disturbed and undisturbed root zone area with a rock saw or chain trencher to minimize damage to undisturbed root zone.
2. Trenching area shall be designated on the Site Demolition Plan and exact trench location shall be painted on the ground by the University Landscape Architect.
3. Protective root cuts shall be backfilled with topsoil immediately after trenching.
4. Where cuts are over 3' in depth and in a root zone area, a chain trencher shall first be used to cut a vertical edge prior to further excavation.
5. Protective root cutting shall also be used to cut roots of trees to be removed out of root zones of trees to remain.

3.03 Tree Protection Fencing

B. Tree protection fencing shall be completed by the Contractor as follows:

1. Tree protection fencing is designated on the Site Demolition or Grading Plan. Exact location will be marked in the field by the University Landscape Architect. Wherever possible, the area enclosed by the tree protection fencing shall be equal to the dripline – the edges of the outermost branches
2. Contractor shall provide maintenance and repair of fence during construction.
3. Fence shall be removed after completion of construction.
4. No access to fenced areas shall be permitted without prior approval by the University Landscape Architect.

SECTION 32 01 90.33 - TREE AND SHRUB PRESERVATION**3.04 Tree Protection Construction Road**

A. Where vehicular access or materials laydown space is required to occur over tree root zones (within the tree dripline) or in lawn areas where soil compaction is to be avoided, the University Landscape Architect may approve temporary Tree Protection Construction Roads to be installed by the Contractor consisting of the following:

1. One layer of ½” plywood, edges overlapping, laid on ground surface.
2. One layer of filter fabric, laid on plywood, edges turned up 8” against adjacent fencing to contain crushed stone.
3. 8” crusher-run stone laid on filter fabric.
4. Exact location of road(s) will be marked on site by University Landscape Architect.
5. Contractor shall provide maintenance and repair of road(s) during construction.
6. Road(s) shall be removed after completion of construction.
7. In some cases, where an area is to be used only for materials laydown, or for light vehicular traffic of very short duration, the University Landscape Architect may approve the installation of only a double layer of ½” plywood to protect the tree root zone or lawn area.

- END OF SECTION -

SECTION 32 11 23 - AGGREGATE BASE COURSE**Part 1 – General****1.01 Scope**

- A. Preparing and stabilizing subgrade to receive a base or pavement.
- B. Placing and compacting base material.

1.02 Related Work

- A. Section 31 11 00: Clearing and Grubbing
- B. Section 31 23 00: Excavation and Fill
- C. Section 32 12 16: Asphalt Paving
- D. Section 32 13 13: Concrete Walks

1.03 Quality Assurance

- A. Perform work in accordance with Tennessee Department of Transportation Standard Specifications for Road and Bridge Construction, 1995 Edition.
- B. The Contractor shall provide material testing and inspection for quality control during paving operations.

1.04 Reference Standards

- A. Graduation of stone materials will be performed in accordance with ASTM C136.

Part 2 – Products**2.01 Materials**

- A. Mineral aggregate concrete base for asphaltic concrete pavement:
 - 1. Section 303, Grading “D”, Pug Mill mix, State Highway Specifications.

SECTION 32 11 23 - AGGREGATE BASE COURSE**Part 3 – Execution****3.01 Preparation**

- A. Verify compacted subgrade is dry and has been approved to the work of this Section.
- B. Verify gradients and elevations of subgrade are correct.
- C. Field Quality Control:
 - 1. Proof-roll subgrades that have been exposed to weather.
 - 2. Remove materials identified by Testing Agency Personnel as being unsuitable. Backfill and compact such areas.

3.02 Placing Base Course

- A. Perform aggregate blending by approved stationary or travel plant methods. Mixing in stockpiles or on roadway will not be acceptable.
- B. Spread base material uniformly over the area to produce required lines, grades and cross-section after compaction.
 - 1. Indicated thickness of 6 inches or less may be constructed in a single course.
 - 2. Spread and compact thickness greater than 6 inches in at least two courses.
- C. Level and contour surfaces to the elevations and gradients indicated.
- D. Compact each layer to at least 95% of the modified proctor maximum dry density.
- E. Perform 5 density tests for every 10,000 square yards. The Geotechnical Engineer may require more frequent testing.
- F. Adjust moisture content to achieve near optimum moisture content prior to compaction. If excess water is apparent, scarify aggregate and aerate to reduce the moisture content.
- G. Use mechanical hand tamping equipment in areas inaccessible to compaction equipment.

3.03 Tolerances

- A. Flatness: Maximum variation of $\frac{1}{4}$ inch measured with a 10 ft. straight edge.
- B. Scheduled compaction thickness: Within $\frac{1}{4}$ inch.
- C. Variation from true elevation: Within $\frac{1}{2}$ inch.

SECTION 32 11 23 - AGGREGATE BASE COURSE

3.04 Finishing And Maintenance

- A. Finish surfaces by rolling with a smooth steel wheel roller. Water the surface and spread loose stones prior to rolling.
- B. Repair soft, yielding areas that develop in the final rolling.
- C. Maintain final surface in smooth and uniform condition until base course is covered by subsequent pavement construction.
- D. Protect surface from silting or erosion until placement of final pavement construction.
- E. Where areas are disturbed by traffic, weather or other means, grade and re-compact as necessary.

- END OF SECTION -

SECTION 32 12 16 - ASPHALT PAVING**Part 1 – General****1.01 Scope**

A. Mixing, spreading, compacting and finishing of bituminous pavements for base, leveling and surface courses on roads, parking lots, and other areas.

1.02 Related Work

A. Section 01 45 29: Testing Laboratory Services

B. Section 31 23 00: Site Excavation

C. Section 32 11 23: Aggregate Base Course

D. Section 31 22 19.13: Spreading and Grading Topsoil

E. Section 32 17 23: Pavement Marking

1.03 Quality Assurance

A. Perform work in accordance with the State of Tennessee Department of Transportation-Bureau of Highways-Standard Specifications for Road and Bridge Construction, latest Edition, hereinafter referred to as “State Highway Specifications.” Measurements and payments portions of those State Specifications do not apply to work performed under this contract.

B. Mixing Plant: Comply with requirements of State Highway Specifications.

C. Qualifications of Asphaltic Concrete Producer: Use only materials which are furnished by a bulk asphaltic concrete producer regularly engaged in production of hot-mix, hot-laid asphaltic concrete.

1.4 Paving Quality Requirements

A. General: In addition to other specified conditions, comply with the following minimum requirements.

1. Test in-place asphaltic concrete courses for compliance with requirements for density, thickness and surface smoothness.
2. Provide final surfaces or uniform texture, complying with required grades and cross-sections.
3. Take not less than 4 inches diameter pavement specimens for each completed course, from locations as directed by the testing agency.

3. Repair holes from test specimens as specified for patching defective work.

B. Density

1. Compare density of in-place material against laboratory specimens of same asphaltic concrete mixture, when subjected to 50 blows of standard Marshall hammer on each side of specimen.
2. Minimum acceptable density of in-place course material is 97% of the recorded laboratory specimen density.

SECTION 32 12 16 - ASPHALT PAVING**1.05 Regulatory Requirements**

A. Comply with applicable local standards, codes and ordinances for paving work on public property.

1.06 Tests

A. Testing and analysis of asphaltic mix will be performed under provisions of Division 1 of the Specifications.

1.07 Submittals

A. Samples: Provide samples of materials for laboratory testing and job-mix design as required by Owner's Representative.

B. Certificates:

1. Provide certificates, in lieu of laboratory test reports.
2. Certify that materials comply with specification requirements.
3. Signed by asphaltic concrete producer and Contractor.

1.08 Environmental Requirements

A. Do not place asphalt when the base surface temperature is less than 40°F.

B. Do not apply materials when substrate is wet or contains sufficient moisture to prevent uniform distribution and proper penetration.

Part 2 – Products

A. Tack Coat: Emulsified asphalt SS-1, diluted with equal parts of water.

B. Asphalt Cement: ASTM D946, 60-70 penetration grade.

C. Stone Base: Grading D pug mill mix in accordance with Tennessee Department of Transportation Specification Section 303.

1. Coarse aggregate: ASTM D692.
2. Fine aggregate: ASTM D1073.

D. Mineral filler: Shall meet the requirements of AASHTO M17 finely ground particles of limestone, hydrated lime, Portland cement, or other approved mineral dust, free from foreign matter.

2.01 Asphalt Paving Mix

A. Use dry materials to avoid foaming. Mix uniformly.

B. Mix designation: State Highway Specification Sections as follows:

SECTION 32 12 16 - ASPHALT PAVING

1. Asphaltic Concrete Surface Course: Section 411, grading "E."
2. Binder Course: Section 307, grading "B modified."

C. The pavement shall be constructed in accordance with Sections 407 and 303 of the State Highway Specifications.

Part 3 – Execution**3.01 Inspection**

- A. Verify compacted subgrade is dry and ready to support paving and imposed loads.
- B. Verify gradients and elevations of base are correct.
- C. Beginning of installation means acceptance of substrate.

3.02 Preparation

A. Prepare mix materials and place of deposit in accordance with referenced state highway specifications.

B. Tack Coat:

1. Apply to contact surfaces of concrete items which abut pavement.
2. Apply to contact surfaces of existing asphalt or concrete pavement at the rate of .05 gal/sq. yd. of surface.

C. Frames of subsurface structures:

1. Coat surfaces of new and existing frames with oil to prevent bond with asphalt paving.
2. Set to be flush with finish surface and surround with a ring of compacted asphaltic concrete to one inch below top of frame. Adjust as required to meet paving.
3. Provide temporary covers over openings until completion of rolling operations.

3.03 Placing Asphalt Pavement

A. Place materials in accordance with referenced State Highway Specifications.

B. Place, spread, and strike-off to compacted thickness indicated with paving machine, except that inaccessible and small areas may be placed by hand.

C. Place topping course within 2 hours of placing and compacting binder course.

D. Compact pavement by rolling. Do not displace or extrude pavement from position. Hand compact area inaccessible to rolling equipment.

SECTION 32 12 16 - ASPHALT PAVING

1. Average relative density: Minimum of 97%.
2. Individual relative density: Minimum of 94%.

E. Develop rolling with consecutive passes to achieve even and smooth finish of uniform texture, without roller marks.

F. Make joints between successive days work, or between old and new pavements in accordance with referenced State Highway Specifications. Ensure a continuous bond is attained.

3.04 Tolerances

- A. Flatness: $\pm \frac{1}{4}$ inch measured with a 10 ft. straight edge.
- B. Compacted scheduled thickness: $\pm \frac{1}{4}$ inch of design thickness.
- C. Variation from true elevation: 0.05 feet.

3.05 Patching

- A. Remove defective or deficient areas for full depth of course.
 1. Cut sides parallel and perpendicular to direction of traffic with edges vertical.
 2. Apply tack coat to exposed surfaces and place asphalt on prepared surfaces as specified above.

3.06 Field Quality Control

- A. Field inspection and testing will be performed as defined in Division 1 of the specifications.

3.07 Protection

- A. Immediately after placement, protect pavement from mechanical injury for 7 days.
- B. Cover openings of substrate structures in paved area until permanent coverings are placed.

3.08 Schedule of Pavement Sections

- A. Place and compact materials to the thickness called for on the Drawings.

- END OF SECTION -

SECTION 32 13 13 CONCRETE WALKS AND PAVING**Part 1 – General****1.01 Description of Work**

- A. The extent of concrete work is shown on drawings.
- B. For LEED Materials Credit 5.1 and 5.2, provide concrete components that are extracted or manufactured within 500 miles of project site.

1.02 Quality Assurance

- A. Codes and Standards: Comply with local governing regulations if more stringent than herein specified.

1.03 LEED Requirements for Project Certification

- A. Invoices and documentation from manufacturer or supplier to include the amounts of post-consumer and post-industrial recycled content by weight for all materials used, and city and state of origin of all materials and city and state of final assembly.
- B. Documentation from supplier of surface reflectance of finished concrete, or contractor to provide measurements of reflectance.

1.04 Job Conditions

- A. Traffic Control: Maintain access for vehicular and pedestrian traffic as required for other construction activities.
- B. Utilize flagmen, barricades, warning signals and warning lights as required.

Part 2 - Products**2.01 Materials**

- A. Forms: Steel, wood, or other suitable material of size and strength to resist movement during concrete placement and to retain horizontal and vertical alignment until removal. Use straight forms, free of distortion and defects.
- B. Use flexible spring steel forms or laminated boards to form radius bends as required.
- C. Coat forms with non-staining form release that will not discolor or deface surface of concrete.
- D. Joint Dowel Bars: Plain steel bars, ASTM A 615, Grade 40. Cut bars true to length with ends square and free of burrs.
- E. Sealing Compound – for exposed aggregate finish ONLY: DSG-J.21 Acrylic cure seal and dustproofer 14.

SECTION 32 13 13 - CONCRETE WALKS AND PAVING**2.02 Concrete Mix and Design**

A. Use one brand of concrete throughout project as supplied by either I.M.I. Ready Mix, Nashville, TN (VU Sidewalk Mix #835) or Metro Ready Mix, Nashville, TN (VU Sidewalk Mix #44)

B. Mixture to be composed of the following:

Portland cement: Type 1 470 lbs./C.Y.
River Sand: 1300 lbs./C.Y.
Stone: (Brown river gravel 1/2" or less), 1600 lbs./C.Y.
Water: 240/C.Y.
3/4" Fibermesh: 1.5 lb./C.Y.
Fly Ash: 70 lbs./C.Y.

C. Owner to approve sample.

D. Design mix to produce normal-weight concrete consisting of Portland cement, aggregate, water-reducing or high-range water reducing as mixture (super-plasticizer), air-entraining admixture and water to produce the following properties:

1. Compressive Strength: 3500 psi, minimum at 28 days.
2. Slump Range: 3" for concrete.

E. Adjustment to Concrete Mixes: Mix design adjustments may be requested by Contractor when characteristics of materials, job conditions, weather, test results, or other circumstances warrant; at no additional cost to Owner and as accepted by Owner. Laboratory test data for revised mix design and strength results must be submitted to and accepted by Owner before using in work.

F. Admixtures:

1. Use water-reducing admixture in all concrete.
2. Use accelerating admixture in concrete slabs placed at ambient temperatures below 50° F (10° C).
3. Use air-entraining admixture in all concrete. Add air-entraining admixture at manufacturer's prescribed rate to result in concrete at point of placement having air content within following limits:

Concrete structures and slabs exposed to freezing and thawing or subjected to hydraulic pressure: 6% to 8% for maximum 3/4" aggregate

4. Use admixtures for water-reducing and set-control in strict compliance with manufacturer's directions.

G. Slump limits: Proportion and design mixes to result in concrete slump at low point of placement as follows:
Ramps and Sloping Surfaces: Not more than 3".

H. Polypropylene Fibers: Use 1.5 pounds of fibers per cubic yard of concrete. Introduce the fibers into the concrete mix per the manufacturer's recommendations.

2.03 Concrete Mixing

A. All concrete to be supplied by I.M.I. Ready Mix or Metro Ready Mix Concrete, Inc.

SECTION 32 13 13 - CONCRETE WALKS AND PAVING

B. Job-Site Mixing: Mix materials for concrete in appropriate drum type batch machine mixer. For mixers of one cu. yd., or smaller capacity, continue mixing at least 1-1 1/2 minutes, but not more than 5 minutes after ingredients are in mixer, before any part of batch is released. For mixers of capacity larger than one cu., yd., increase minimum 1-1 1/2 minutes of mixing time by 15 seconds for each additional cu. yd., or fraction thereof.

C. Job-Site mixing shall be allowed for minor applications only.

D. Ready-Mix Concrete: Comply with requirements of ASTM C 94, and as herein specified.

E. Maximum of 2 gallons of water per cubic yard may be added to the batch of material of insufficient slump.

F. During hot weather, or under conditions contributing to rapid setting of concrete, a shorter mixing time than specified in ASTM C 94 may be required.

G. When air temperature is between 86° F (30° C) and 90° F (32° C), reduce mixing and delivery time from 1-1/2 hours to 75 minutes, and when air temperature is above 90° F (32° C), reduce mixing and delivery time to 60 minutes.

Part 3 - Excavation**3.01 Excavation**

A. When excavating, avoid tearing tree roots. Saw cut any tree roots that interfere with walk layout. Excavate 10 inches. In areas where tree roots are extensive, Owner may direct Contractor to install walks above existing grade to avoid excavation.

B. Topsoil shall be stockpiled at location on campus as designated by Owner.

3.02 Surface Preparation

A. Remove loose material from compacted base surface immediately before placing concrete.

B. Proof-roll prepared base surface to check for unstable areas and need for additional compaction. Do not begin paving work until such conditions have been checked by Campus Planning & Construction, Vanderbilt, and have been corrected and are ready to receive paving. Spread 4" gravel base and proof-roll before placing 6" concrete.

3.03 Preparation of Form Surfaces

A. Coat contact surfaces of forms with a form-coating compound before reinforcement is placed.

B. Thin form-coating compounds only with thinning agent of type, and in amount, and under conditions of form-coating compound manufacturer's directions. Do not allow excess form-coating material to accumulate in forms or to come into contact with concrete surfaces against which fresh concrete will be placed. Apply in compliance with manufacturer's instructions.

C. Coat steel forms with a non-staining, rust-preventative form oil or otherwise protect against rusting. Rust-stained steel formwork is not acceptable.

SECTION 32 13 13 - CONCRETE WALKS AND PAVING**3.04 Form Construction**

A. Replacement inspection: It shall be the contractor's responsibility to notify Campus Planning at least 24 hours prior to placing any forms.

B. Set forms to required grades and lines, rigidly braced and secured. Install sufficient quantity of forms to allow continuous progress of work and so that forms can remain in place at least 24 hours after concrete placement.

C. Clean forms after each use, and coat with form release agent as often as required to ensure separation from concrete without damage.

3.05 Concrete Placement

A. Preplacement Inspection: It shall be the Contractor's responsibility to notify Campus Planning at least 24 hours prior to placing any concrete.

B. All walks shall be 6" thick unless shown otherwise on drawings.

C. Pour one 3' x 3' test panel of concrete pavement with finish to be selected by Owner.

D. Do not place concrete until base and forms have been checked for line and grade. Moisten base as required to provide a uniform dampened condition at time concrete is placed. Do not place concrete around manholes or other structures until they are at required finish elevation and alignment.

E. Coordinate the installation of joint materials and moisture barriers with placement of forms.

F. Deposit and spread concrete in a continuous operation between transverse joints, as far as possible. If interrupted for more than 1/2 hour, place a construction joint.

G. Bring slab surfaces to correct level with straightedge and strikeoff. Use bull floats or darbies to smooth surface, free of humps or hollows. Do not disturb slab surfaces prior to beginning finishing operations.

H. Cold Weather Placing: Protect concrete work from physical damage or reduced strength which could be caused by frost, freezing actions, or low temperatures, in compliance with ACI 306 and as herein specified.

I. When air temperature has fallen to or is expected to fall below 40° F (4° C), uniformly heat water and aggregates before mixing to obtain a concrete mixture temperature of not less than 50° F (10° C), and not more than 80° F (27° C) at point of placement.

J. Do not use frozen materials or materials containing ice or snow. Do not place concrete on frozen subgrade or on subgrade containing frozen materials.

K. Do not use salt and other materials containing antifreeze agents or chemical accelerators, unless otherwise accepted in mix designs.

L. Hot Weather Placing: When hot weather conditions exist that would seriously impair quality and strength of concrete, place concrete in compliance with ACI 305 as specified

SECTION 32 13 13 -CONCRETE WALKS AND PAVING

M. Cool ingredients before mixing to maintain concrete temperature at time of placement below 90° F (32° C). Mixing water may be chilled or chopped ice may be used to control temperature provided water equivalent of ice is calculated to total amount of mixing.

N. Wet forms thoroughly before placing concrete.

O. Use water-reducing retarding admixtures (Type D) when required by high temperatures, low humidity, or other adverse placing conditions.

P. Curbs and Gutters: Automatic machine may be used for curb and gutter placement at Vanderbilt's option. If machine placement is to be used, concrete mix to be same as sidewalk with sandblasted finish as specified. Machine placement must produce curbs and gutters to required cross-section, lines, grades, finish, and jointing as specified for formed concrete. If results are not acceptable, remove and replace with formed concrete as specified.

3.06 Joints

A. Pre-placement Inspection: It shall be the responsibility of the contractor to notify Campus Planning at least 24 hours prior to the placement of any joints.

B. General: Construct expansion and weakened-plane construction joints true-to-line with face perpendicular to surface of concrete. Construct transverse joints at right angles to the centerline, unless otherwise indicated.

C. When joining existing structures, place transverse joints to align with previously placed joints, unless otherwise indicated.

D. Construction and Control Joints: "Form A Key" metal keyed joint with removable cap. Available from Enco Materials.

E. Expansion Joints: Provide 1/2" bituminous felt joint filler for expansion joints abutting concrete curbs, catch basins, man-holes, inlets, structures, walks and other fixed objects, unless otherwise indicated.

F. Locate expansion joints at 30' o.c. for each pavement lane, unless otherwise indicated.

G. Extend joint fillers full-width and depth of joint. Place top of joint filler flush with finished concrete surface. Do not use plastic cap on expansion joint.

H. Furnish joint fillers in one-piece lengths for full width being placed, wherever possible. Where more than one length is required, lace or clip joint filler sections together.

3.07 Concrete Finishing

A. After striking-off and consolidating concrete, smooth surface by screeding and bull floating. Use hand methods only where mechanical floating is not possible. Adjust floating to compact surface and produce uniform texture, working gravel below the finish surface.

B. After floating, test surface for trueness with a 10' straight-edge. Distribute concrete as required to remove surface irregularities, and refloat repaired area to provide a continuous smooth finish.

C. Work edges, gutters, back top edge of curb, and formed joints with an edging tool, and round to 1/2" radius, unless otherwise indicated. Eliminate tool marks on concrete surface.

SECTION 32 13 13 -CONCRETE WALKS AND PAVING

D. Do not remove forms for 24 hours after concrete has been placed. After form removal, clean ends of joints and point-up any minor honeycombed areas. Remove and replace area or sections with major defects, as directed by Landscape Architect. Rub surfaces with a magnesium hand float, sealing all holes and smoothing the surface.

3.08 Exposed Aggregate Finish Only

A. Apply Aggretex "H" retardant, by A.C. Horn, Rugasol C/S/, by Sika, or approved equal, to surface in strict accordance with manufacturer's directions for exposing approximately 1/8" of surface aggregate. After 24 hours, remove matrix by scrubbing with stiff fiber brushes and hosing off. For slab edges and step risers, coat forms with Aggretex "F" or Rugasol FD according to manufacturer's directions and follow with cleaning as above.

B. Prepare samples of both methods for approval.

3.09 Concrete Curing and Protection

A. General: Protect freshly placed concrete from premature drying and excessive cold or hot temperatures.

B. Start initial curing as soon as free water has disappeared from concrete surface after placing and finishing. Weather permitting, keep continuously moist for not less than 7 days.

C. Begin final curing procedures immediately following initial curing and before concrete has dried. Continue final curing for at least 7 days in accordance with ACI 301 procedures. Avoid rapid drying at end of final curing period.

D. Curing Methods: Perform curing of concrete by moist curing, by moisture-retaining cover curing, by membrane curing, and by combinations thereof, as herein specified.

E. Provide moist curing by following methods:

1. Keep concrete surface continuously wet by covering with water.
2. Continuous water-fog spray.
3. Covering concrete surface with specified absorptive cover, thoroughly saturating cover with water and keeping continuously wet. Place absorptive cover to provide coverage of concrete surfaces and edges, with 4" lap over adjacent absorptive covers.

F. Provide moisture-cover curing as follows: Cover concrete surfaces with moisture-retaining cover (polyethylene-coated burlap waterproof paper, polyethylene film) for curing concrete, placed in widest practicable with sides and ends lapped at least 3" and sealed by waterproof tape or adhesive. Immediately repair any holes or tears during curing period using cover material and waterproof tape.

G. Curing Formed Surfaces: Cure formed concrete surfaces, including undersides of beams, supported slabs and other similar surfaces exposed to heating by the sun or to wind by keeping forms wet in place for the full curing period or until forms can be safely removed. If forms are removed, continue curing by methods specified above, as applicable till the end of the full curing period.

H. Remove control joint caps after curing is complete.

SECTION 32 13 13 -CONCRETE WALKS AND PAVING**3.10 Sandblast Finish Only**

- A. Sandblast concrete at 7 to 10 days.
- B. Test panel is to be sandblasted while University Landscape Architect is present on site. Landscape Architect will choose the finish that Vanderbilt will accept. Notify Campus Planning no later than 3 days prior to sandblasting.
- C. Remove control joint caps after sandblasting is complete.

3.11 Repairs and Protections

- A. Replace broken or defective concrete, as directed by Campus Planning.
- B. Drill test cores where directed by Campus Planning, when necessary to determine magnitude of cracks or defective areas. Fill drilled core holes in satisfactory pavement areas with Portland cement concrete bonded to pavement with epoxy resin grout.
- C. Sweep concrete pavement and wash free of stains, discolorations, dirt and other foreign material just prior to final inspection.
- D. Drill test cores where directed by Campus Planning, when necessary to determine magnitude of cracks or defective areas. Fill drilled core holes in satisfactory pavement areas with Portland cement concrete bonded to pavement with epoxy resin grout. Haul off all debris.

3.12 Quality Control Testing During Construction

- A. If testing is required, it shall be at Owner's expense as directed by Owner. All defective materials shall be removed and replaced at Contractor's expense and at no cost to Owner.

3.13 Topsoil Backfilling And Lawn Repair

- A. All new walk edges and disturbed areas resulting from construction shall be backfilled with topsoil by contractor. Topsoil must be furnished as specified: equivalent to Maury silt loam: 12-27% clay, 20-50% sand, 40-70% silt, permeability 2-6 inches per hour, low shrink-swell potential, pH 6.5 - 7.0, minimum 2% organic matter. Topsoil shall be tested for physical properties, organic content, pH and nutrients content by a reputable soil testing lab. Test results shall be submitted to Owner for approval before topsoil is brought to site.
- B. All new walk edges shall be sodded with a 24" width of mixed fescue sod after backfilling unless directed otherwise by University Landscape Architect. Sod shall be thoroughly hand watered by sod contractor immediately after installation of sod. In non-irrigated areas, sod contractor shall water sod every day for 2 weeks, or until final acceptance by Owner, whichever comes first. In irrigated areas, sod contractor shall contact Owner to arrange irrigation scheduling to insure survival of sod. Other disturbed lawn areas shall be seeded with a mixture of 50% Rebel fescue and 50% Falcon fescue.
- C. Coordinate scheduling of backfilling and seeding or sodding with Irrigation Contractor. Irrigation system installation should be complete before backfilling begins.

-END OF SECTION-

SECTION 32 17 23 - PAVEMENT MARKINGS**Part 1 – General****1.01 Scope**

A. Marking of pavement including surface preparation and painting on bituminous or concrete surface.

1.02 Acceptance Procedure

A. Typical Sample Analysis

B. Certification that paint meets requirements.

Part 2 – Products**2.01 Ready-Mixed Paint**

A. Paint: Porter traffic paint, colors as follows:

1. Parking lines and directional arrows: White

2. No Parking areas: White

3. Fire Lane: Yellow

4. Handicapped Symbols: Blue and White

B. Substitutions: Materials of the same function and performance are acceptable under provisions defined in Division 1 of the Specifications.

Part 3 – Execution**3.01 Installation**

A. Prepare surface and apply paint with provisions of consistent agitation of paint with guns capable of applying a solid consistent marking.

B. Apply paint markings to have true, sharp edges and ends, with lines of correct lengths, widths, and curvatures. Paint application to be performed in accordance with manufacturer's recommendations.

C. Protection:

1. Take precautions necessary to insure that paint does not soil adjacent surfaces.

2. Place warning signs and traffic cones or similar devices to protect markings from being tracked by pedestrians or vehicles.

3. Efface any tracked paint from adjacent areas and repair pavement markings.

- END OF SECTION -

SECTION 32 33 00 -SITE IMPROVEMENTS

Part 1 – General**1.01 Work Included**

A. The Designer will coordinate any alterations to the exterior environment with the University Landscape Architect through the Project Manager.

Part 2 – Products**Part 3 – Execution****3.01 Metal Fences**

A. Copies of standard fence details may be obtained from the University Landscape Architect.

3.02 Exterior Signage

A. Standard campus prototypes do exist for exterior signage. The goal is for visual continuity by consistently using the same graphic format, layout, color, etc. each time the need for a specific type of signage arises. Any sign type not discussed here should be addressed through the Project Manager.

3.03 Building Signs

A. A freestanding building-identification prototype exists for placement in the landscape when approved on a case-by-case basis through Campus Planning. Use of such signs is discouraged throughout campus open-landscape areas approached only by foot, but is generally allowed along street and parking lot edges from which the building is primarily approached.

3.04 Parking Lot Signs

A. Standard campus signage identifying the lot number and zone must be placed at all vehicular entrances into parking lots. These are procured through the campus Traffic and Parking Division; arrange through Project Manager.

3.05 Exterior Directional Graphics

A. Two levels of vehicular-oriented campus perimeter signage are utilized. Primary Campus Destinations with directional arrows are listed on First-Contact Signs at key approach points.

B. Secondary Hand-off Signs are then placed as required to direct visitors to noted destinations. A Building Sign is allowed at the final point nearest the facility at which those in a vehicle would likely see it. All exterior graphics are coordinated through Campus Planning.

3.06 Parking Barriers

A. Standard campus bollards are 4" square steel with tapered caps. Copy of details may be obtained from the University Landscape Architect.

SECTION 32 33 00 -SITE IMPROVEMENTS**3.07 Bicycle Racks**

A. Copy of standard detail may be obtained from the University Landscape Architect.

3.08 Site Lighting

A. Two types of pole fixtures are approved for use on the Vanderbilt main campus. The University Landscape Architect and the Project Manager will determine which type is to be used at each project. The two types are:

1. Globe type fixture on 4" round pole: Architectural Area Lighting Co. #ALB18CGR5175MH-120V-4RSA10DBA with smoke bronze globe. Distributed by Wesco.
2. Canopy type fixture on reverse tapered pole: Fixture: Cooper Lighting Woodbridge #MPW1712955BZ Pole: Hapco A85475 Anodized Bronze color. Custom fiberglass bonnet, to be used in lieu of bonnet that comes with fixture, is available from the Plant Operations storeroom (stock # 13550).

B. One type of pole fixture is approved for use on the Peabody Campus:

1. Canopy type fixture on round tapered pole: Holophane #CW-2A175MH-12-BZ-CA fixture, #AX-RT-10-J-1 pole. Sales Representative: Sean Clare (885-2831).

- END OF SECTION -

SECTION 32 80 00 - IRRIGATION**Part 1 – General****1.02 Guidelines and Standards**

Contractor shall refer to the SBS (Appendix A) and Landscape Strategic Plan (Appendix C) for more information and detailed requirements for water conservation, irrigation systems requirements, control equipment, etc.

1.03 Contractor Qualifications

A. Contractor must have at least two years of experience in the irrigation industry.

B. Contractors will have successfully installed at least two projects of comparable size or show adequate proof of qualifications as may be deemed necessary by owners.

1.03 Work Included**A. Extent**

1. The contractor shall furnish all labor, materials and equipment for the proper installation of the irrigation system. The work includes, but is not necessarily limited to, the following:

- a. Trenching and backfill
- b. Automatically controlled irrigation system
- c. Test all systems and make operative
- d. "As-built" drawings

2. Contractor to provide tap, meter, backflow preventer, pump and/or electrical service to controller as specified on the drawings.

B. Permits and Fees: The contractor shall obtain all permits and pay required fees to any governmental agency having jurisdiction over the work. Inspection required by local ordinances during the course of construction shall be arranged as required. On completion of the work, satisfactory evidence shall be furnished the Owner to show that all work has been installed in accordance with the ordinances and code requirements.

C. Approval: Wherever the terms "approve", "approval," or "approved" are used in the specification, they shall mean the approval of the Owner in writing.

D. Before any work is started, a conference shall be held between the contractor and the Owner concerning the work under this Contract. Mandatory weekly meetings will be held with the Owner while the work is being done.

E. Coordination: The Contractor shall coordinate and cooperate with other contractors to enable the work to proceed as rapidly as possible.

F. Inspection of the Site

1. The contractor shall acquaint himself or herself with all site conditions. The contractor may be required to contact Tennessee One-Call to locate and mark the locations of all underground utilities on the project site. The owner shall reimburse the contractor for the cost of this service. The contractor shall be responsible for insuring that utility markings remain legible throughout the duration of the project. Should utilities not shown on the plans or marked by the locator service be

SECTION 32 80 00 - IRRIGATION

found during

2. excavations, contractor shall promptly notify the Owner for instructions as to further action. Failure to do so will make the Contractor liable for any and all damage thereto arising from his operations subsequent to discovery of such utilities not shown on plans.
3. Contractor shall make necessary adjustments in the layout as may be required to connect to existing stubouts, should such stubouts not be located exactly as shown, and as may be required to work around existing work at no increase in cost to the Owner.

G. Protection of Existing Plants and Site Conditions: The Contractor shall take necessary precautions to protect site conditions to remain. All work in the vicinity of trees shall be in accordance with Vanderbilt Tree Protection Specifications. Should damage be incurred, the Contractor shall repair the damage to its original condition at his own expense.

H. The Owner reserves the right to substitute, add, or delete any material or work as the work progresses. Adjustment to the contract price shall be negotiated.

I. The Owner reserves the right to reject materials or work which does not conform to the Contract Documents. Rejected work shall be removed or corrected at the earliest possible time.

J. Work Schedule: Within 10 days after award of the Contract, the contractor shall submit to the Owner a work schedule.

K. "As-Built" Irrigation Drawings: Prepare an "As-Built" drawing on 4 mil double matted mylar which shall show deviations from the bid documents made during construction affecting the main line pipe, controller locations, remote control valves, quick-coupling valves, all sprinkler heads, and manual drains. The drawings shall also indicate and show approved substitutions of size, material and manufacturer's name and catalog number. The drawings shall be delivered to the Owner before final acceptance of the work.

L. Final Acceptance: Final acceptance of the work may be obtained from the Owner upon the satisfactory completion of all work.

M. Guarantee: All work shall be guaranteed for one year from date of acceptance against all defects in material, equipment, and workmanship. Guarantee shall also cover repair of damage to any part of the premises resulting from leaks or other defects in material, equipment, and workmanship to the satisfaction of the Owner. Repairs, if required, shall be done promptly at no cost to the Owner.

1.03 LEED Requirements for Project Certification

A. Invoices and documentation from manufacturer or supplier to include the amounts of post-consumer and post-industrial recycled content by weight for all materials used, and city and state of origin of all materials and city and state of final assembly.

Part 2 - Products**2.01 General**

A. All materials throughout the system shall be new and in perfect condition.

B. No deviations from specifications shall be allowed unless approved by Owner.

SECTION 32 80 00 - IRRIGATION**2.02 P.V.C. Pipe and Fittings**

- A. All plastic pipe from sizes 3/4" through 1-1/2" should be Class 200 Polyvinyl Chloride Pipe (P.V.C.), Type 1120 or 1220, and shall conform to CS-256-63.
- B. P.V.C. pipe shall be continuously marked with identification of the manufacturer, type, class and size.
- C. All fittings to be used on specified P.V.C. pipe shall be Schedule 40 P.V.C., Type 1, and must be of domestic manufacture. All fittings shall be identified as to pressure rating or schedule.
- D. Solvent for use of P.V.C. pipe and fittings shall be of a type approved by the manufacturer of the pipe.
- E. All plastic pipe from sizes 2" through 4" shall be belled-spigot type, unplasticized P.V.C., Class 200.
- F. Fittings for belled-spigot type pipe shall be of the same manufacture as the pipe and shall be either unplasticized P.V.C. or asbestos-cement with brass inserts for tapped outlets.
- G. Make all connections between plastic pipe and metal valves or steel pipe with threaded fittings, using plastic male adapter
- H. Cap or plug all openings as soon as lines have been installed to prevent the entrance of materials that would obstruct the pipe. Leave in place until removal is necessary for completion of installation.

2.03 Risers and Swing Joint Nipples

- A. Sprinkler heads using less than 6.5 gpm shall be connected to lateral line with 3/8" poly pipe (.69-.70, O.D., .59-.60 I.D., 100 wall thickness, 80 psi pressure rating) with insert fittings.
- B. Sprinkler heads using 6.5 to 10 gpm shall be connected to lateral line with a P.V.C triple swing joint with Schedule 80 nipple and Schedule 40 P.V.C or Marlex street el.

2.04 115 Volt Electric Wiring

- A. All 115 volt AC wiring shall be installed in accordance with local electric codes.
- B. 115 volt service to controllers shall consist of one black and one white wire with ground.
- C. All wiring shall be located in rigid conduit and buried to a minimum depth of 18".
- D. All splices in wiring shall be made watertight using approved methods which conform to UL classifications.

2.05 Control Lines

- A. 24-volt electric
1. Electric control lines from controller to automatic valves shall be direct burial UF (U.L. Approved) wire of a different color than the 110 volt service to controllers.
 2. The 24-volt common ground shall be of one continued color and a different color than the other 24 volt lines and the 1120 volt service.

SECTION 32 80 00 - IRRIGATION

3. All wire splicing shall be minimized, with such splices made waterproof with the use of Scotchlok or Pen-Tite kit.
4. All 24-volt wiring shall be done in accordance with existing codes.

2.06 Locator Wiring

- A. Contractor shall install a 16 gauge locator wire on all main and lateral lines.
- B. Wire shall be connected at all pipe intersections to provide a continuous run from the controller box to the ends of the system.
- C. Coil an additional 18" of wire in the controller box to allow attachment of locating device.

2.07 Sprinkler Heads

- A. All sprinkler heads shall be as specified on the irrigation design plan.
 1. The body of the sprinkler shall be constructed of cyclac material, the sprinkler shall be easily serviced from the top of the sprinkler, shall have an accessible screening device, and shall perform to manufacturer's specifications concerning diameter of throw and gallonage at given pressures.
 2. Spacing of the heads on this project shall not exceed the manufacturer's maximum recommendations.
- B. All sprinklers shall be installed as per manufacturer's specifications.

2.08 Control Equipment

- A. Automatic controller shall be specified on the irrigation design plan.
 1. The controller shall be encased in a sturdy, lock able, wall-mount box and must be easily accessible for maintenance.
 2. Minor timing adjustments of the controller shall be possible to be made in the field.
 3. There shall be no time lags between sections or stations and the controller will be of a compatible type for operating the automatic control valve.
 4. If the timing mechanism of the controller has to be removed from the field for service, the controller shall be capable of continued manual operation.
- B. Automatic control valves shall be as specified on the irrigation design plan.
 1. They shall be of the same operation type as the controllers.

SECTION 32 80 00 - IRRIGATION**2.09 Gate Valves**

A. Gate valves shall be of brass with screwed connections, non-rising stems, and cross handles, with a minimum pressure rating of 200 psi.

1. All gate valves shall be installed using a valve box to provide access to the handle.
2. Gate valves shall be used in any case where a manual drain valve is required.

2.10 Manual Drain Valves

A. Shall be installed at all low points in the irrigation system.

B. Locate valves in a valve box with a gravel sump at least 24" deep.

2.11 Automatic Drain Valves

A. Shall be installed where lateral pipe will not drain by manual drain.

2.12 Miscellaneous System Components

A. Sleeves

1. Schedule 40 P.V.C. - Plastic pipe shall be provided under all walks and paving and where indicated on drawings for irrigation piping and control wires.
2. Sleeve shall extend a minimum of 18" beyond edges of paving or construction. Depth of sleeve shall be 12" to 24" below subgrade of paving. To aid in location of sleeve during construction, install a glued elbow fitting at all sleeve ends. Install a vertical pipe from elbow to 6" min. above finished grade. Install a glued cap fitting at top of sleeve extension.

B. Service Saddles

1. All service saddles shall be Smith-Blair double strap, all bronze.

C. Locator Wire

1. All locator wire shall be 16 gauge U.F. Color of locator wire shall be different than that of any control wires. Locator wire shall extend continuously from controller along all main and lateral lines. At controller, 18" of locator wire shall be coiled in controller box and tagged as follows: Locator wire only - do not use for control wire.

Part 3 - Execution**3.01 Protection of Work and Property**

A. The Contractor shall continuously protect both his work and the Owner's property from damage arising in connection with work on this contract.

SECTION 32 80 00 - IRRIGATION

B. The Contractor shall avoid damage to any buildings, equipment, utilities, sidewalks, landscaping, above ground or underground structures or installations of any kind, and shall be held responsible for any damage that occurs as a result of his work or leakage of the irrigation system which he is installing.

C. The Contractor shall operate or drive his equipment or vehicles only in areas or corridors designated by Owner before work is commenced.

D. The Contractor shall adequately protect adjacent property as provided by law and shall provide and maintain all passageways, guard fences, lights and other facilities for protection required by Vanderbilt.

E. The Contractor shall securely cover all trenches and openings into the section of the system he is working on and components of the system as it is being installed, or barricade with a 6' tall chain-link fence mounted on 8' tall steel posts if excavations are to remain open overnight, to prevent obstructions in the pipe, and the breakage, misuse, or disfigurement of the equipment or hazards to pedestrians.

3.02 Lands for Material Storage

A. The Contractor has the right to erect temporary construction facilities for storage and protection of his materials and equipment on the lands set aside by the Owner for materials storage.

3.03 Handling of Materials

A. The Contractor shall be responsible for correct procedures in loading, unloading, stacking, transporting and handling all materials to be used in the system.

B. The Contractor shall avoid rough handling which could affect the useful life of the equipment.

C. Pipe shall be handled in accordance with the manufacturer's recommendations on loading, unloading, and storage.

3.04 Cleaning Premises

A. The Contractor shall continuously keep a neat and orderly area in which he is installing the system. Disposal of rubbish and waste material resulting from the installation shall be continuous.

B. Upon completion of the system installation, the Contractor shall remove from the Owner's property, at his own expense, all temporary structures, rubbish, and waste materials resulting from the installation of said system.

3.05 Inspection of Work in Progress

A. The Owner shall be responsible for inspecting the Contractor's work in progress and shall notify the Contractor of any work which does not meet the specifications of this contract. The Contractor shall correct such work.

SECTION 32 80 00 - IRRIGATION**3.06 Marking Locations of Irrigation Piping and Sprinkler Heads**

A. The Contractor shall mark the proposed location of all irrigation piping and sprinkler heads on the ground with spray paint prior to trenching. Marked areas shall be limited to one week's worth of work. The Contractor shall notify the Owner of the marking at least three business days prior to the start of trenching and shall not proceed with trenching until receiving written approval of the marking from the Owner. The Contractor is responsible for re-marking lines as necessary so that they remain visible until trenching is done.

3.07 Excavation

A. All excavation shall be unclassified and shall include all materials encountered except materials which cannot be excavated by normal mechanical excavation means (30 hp trencher). Such exceptions shall be brought to the attention of the Owner and an adjustment in price shall be agreed upon before excavation of these areas proceeds. Such price adjustments and agreement shall include responsibility for disposal of the unsuitable materials removed from the trench and the acquiring of additional backfill material.

B. Any trenching to be located within the drip-line of an existing tree shall be done by hand. Any root under 1" in diameter which crosses the trench shall be cut cleanly with pruning shears or a fine-toothed saw. If any roots over 1" in diameter are encountered during trenching, the Owner shall be contacted immediately for a decision on rerouting the piping or cutting the root. All trenching in tree root zone shall run radially to the trees.

C. Minimum depth of cover over piping 2" and larger shall be 18", minimum cover over piping smaller than 2" shall be 12".

D. In existing lawn areas, remove and preserve sod over trenches, and replace it after backfilling trenches.

E. Backfill material shall be free from rocks or other materials which may damage pipe or cause excess settling. Backfilling shall be done in 6" layers and tamped after each layer to reduce settling.

F. Backfilling of trenches containing plastic pipe shall be done when pipe is cool to avoid excessive contraction in cold weather. Such backfilling can be done in early morning hours or the pipe may be water-cooled prior to backfilling procedures.

G. If trenching is necessitated through existing asphalt roadways, the Contractor shall cut the asphalt to the width of the trench prior to trenching. Removal of cut asphalt and replacement of all asphalt shall be the responsibility of the Contractor.

H. The Contractor shall exercise reasonable care to avoid causing damage to any and all underground utilities and structures. The Owner shall advise the Contractor of any underground utilities or structures of which he is aware. Utility locating services shall be called upon to pinpoint location of any underground utilities on the site of the project.

I. All disturbed lawn areas are to be dressed off to finish grade and seeded with a mixture of 50% Rebel Fescue and 50% Falcon Fescue.

3.08 Installation of System Main

A. Installation of the system main shall be in accordance with the Manufacturer's instructions and shall proceed from the point of connection of supply for the system pumping station, reservoir, or existing line.

SECTION 32 80 00 - IRRIGATION

B. Concrete thrust blocks shall be installed at any directional change in the pipeline in accordance with pipe manufacturer's instructions. (Pipe 3" and larger).

C. The main shall be flushed and pressure tested for 24 hours prior to making any lateral connections.

D. Locator wire shall be laid on top of all main lines before closing trench.

3.09 Installation of Lateral Lines

A. Lateral lines may be installed by standard trenching techniques or by "pulling in" pipe. If the pull-in method is used, the pipe "plow" shall be a vibratory type and equipped with a turf roller device to prevent tearing of the turf. The "Mole or Bullet" which precedes the pipe and is used to form the opening for the pipe, shall not be less than 1" larger in diameter than the outside diameter of the pipe. Starting and finishing holes shall not exceed a 2'-square opening, with the sod removed from such holes to be preserved and replaced. Locator wire shall be pulled in with lateral piping or laid on top of all lateral lines before closing trench.

3.10 Sprinkler Heads

A. All sprinklers shall be installed on swing joints as per manufacturer's specifications.

B. The sprinkler head shall be installed so that the top is slightly above the finished grade level. If finished grade has not been established, the sprinkler will be extended a minimum of 2" above existing level and marked with a stake to prevent damage by equipment.

C. Backfill around the swing joint and sprinkler shall be free of large rocks, roots, or foreign debris.

3.11 Control Lines

A. All control lines shall be installed in a neat and orderly fashion and may be installed in the main and lateral trenching or in their own separate trench. The lines shall be bundled together and taped every 5-10'.

B. Control line connections shall be as approved in a preceding section of these specifications.

3.12 Control Equipment

A. All automatic valves and controllers shall be installed following the recommendations of the manufacturer of said equipment.

B. The location of all controllers shall be approved by the Owner's representative before the actual installation of said controllers.

3.13 Valve Boxes, Drains, Etc.

A. All valve boxes, drain boxes, or any other miscellaneous marker or access box shall be installed so the top of said structure is at finished grade.

3.14 Testing System

A. Upon completion of the irrigation system and after sufficient time has been allowed for solvent weld joints to cure, the entire system shall be tested for proper operation.

SECTION 32 80 00 - IRRIGATION

- B. All air will be flushed from the system and all components will be checked for proper operation.
- C. The Contractor shall request the presence of the Owner in writing at least 48 hours in advance of testing.
- D. The contractor shall repair leaks resulting from tests.
- E. If Owner discovers leak during warranty period, Owner notifies Contractor. Contractor must respond within 48 hours of written notification to begin repairs.

3.15 Balance and Adjustment

- A. The Contractor shall balance and adjust the various components of the sprinkler system so the overall operation of the system is most efficient. This includes a synchronization of the controllers, adjustments to pressure regulators, pressure relief valves, part circle sprinkler heads and individual station adjustment on the controller.
- B. The Contractor has the right to call in the Owner's representative to aid in the balancing and adjustment of the system.

3.16 Notice of Completion

- A. When the Contractor is satisfied that the system is operating properly, that it is balanced and adjusted, that all work and cleanup is completed, he shall issue the notice of completion to the Owner. The notice of completion shall include the request for final inspection with date and time given.

3.17 Final Inspection with Owner's Representative

- A. The Owner will respond to the notice of completion by the Contractor and shall appear at the given time for a tour of the project with the purpose of making it the final inspection.
- B. Any inconsistencies to the specifications shall be noted by the Owner and a written copy of corrections shall be given to the Contractor.

3.18 Acceptance of the System

- A. The Owner may accept the system even though the corrections on the final inspection have not been made by the Contractor. In such a case, there will be deductions for the incomplete or incorrect work based on previous provisions of these specifications. Such deductions shall be made from the final payment.

3.19 As-Built Plan Acceptance

- B. Acceptance of the system is based on the furnishing by the Contractor of a completed "as-built" plan which is acceptable to the Owner or Owner's representative.

3.20 Training of Maintenance Personnel in Operation and Maintenance of System

- A. Upon completion of the system, the Contractor shall train maintenance personnel designated by Owner in the day-to-day operation and maintenance of the system.

SECTION 32 80 00 - IRRIGATION

B. The Contractor shall, at no additional cost to the Owner, conduct one draining and winterizing of the system in November, and one reactivation of the system in March. The Contractor shall notify the Owner in writing at least 14 days prior to conducting winterizing and reactivation, and shall train maintenance personnel designated by Owner in each procedure.

C. The Contractor shall provide three (3) copies of all pertinent operation and maintenance literature to Owner upon final acceptance of the system.

3.21 Warranty and Guarantee Certificates

A. The Contractor shall furnish a certificate of warranty registration and a guarantee or work and materials for a one year period from date of final acceptance of the system. Final payment for the system shall not be made unless this certification is presented to the Owner.

B. Warranty will not include damage due to pilferage, vandalism, or damage by environmental extremes such as earthquakes, floods, etc.

- END OF SECTION -

SECTION 32 90 00 - PLANTING**Part 1 - General****1.01 Work Included**

A. Design of landscaping and all work specified in this section on Planting must ensure adherence to the requirements outlined here and in the Landscape Strategic Plan (Appendix C).

B. Extent of landscape development work is shown on drawings and in schedules.

C. Subgrade Elevations: Excavation, filling and grading required to establish elevations shown on drawings are not specified in this section. Refer to earthwork sections.

1.02 Quality Assurance

A. Subcontract landscape work to a single firm specializing in landscape work.

B. General: Ship landscape materials with certificates of inspection required by governing authorities. Comply with regulation applicable to landscape materials.

C. Do not make substitutions. If specified landscape material is not obtainable, submit proof of non-availability from minimum of 6 suppliers to Owner, together with proposal for use of equivalent material.

D. Analysis and Standards: Package standard products with manufacturers certified analysis. For other material provide analysis by recognized laboratory made in accordance with methods established by the Associates of Official Agriculture Chemists, wherever applicable.

E. Topsoil: At least 2 weeks before delivery of topsoil, furnish Owner with written statement giving location of properties from which topsoil is to be obtained, names and addresses of owners, depth to be stripped, crops grown and insecticides or herbicides used during past 2 years. Also, submit to Owner laboratory tests indicating amount of organic material in topsoil, sand, silt and clay percentages, pH and nutrient quantities.

F. Trees, Shrubs and Plants: Provide trees, shrubs and plants of quantity, size, and genus, species and variety shown and scheduled for landscape work and complying with recommendations and requirements of ANSI Z60.1 "American Standard for Nursery Stock". Provide healthy, vigorous stock, grown in a recognized nursery in accordance with good horticultural practice and free of disease, insects, eggs, larvae and defects such as knots, sun-scald, injuries, abrasions, or disfigurement.

G. Where "matched" or formal arrangements or consecutive order of trees or shrubs are shown, select stock for uniform height and spread, and label with number to assure symmetry in planting.

H. Inspection: The Owner may inspect trees and shrubs either at place of growth or at site before planting, for compliance with requirements for genus, species, variety, size and quality. Owner retains right to further inspect trees and shrubs for size and condition of balls and root systems, insects, injuries and latent defects, and to reject unsatisfactory or defective material at any time during progress of work. Remove rejected trees or shrubs immediately from project site.

SECTION 32 90 00 - PLANTING

I. Inventory: Contractor shall give Owner a complete inventory of trees planted, with data on the following:

1. Species (provide name and species code)
2. Age of tree
3. Measure and record diameter at breast height (4.5 feet from the base on the hill side) of all trees 3" or greater. This information should be logged for all trees under 3" as well, along with the estimated growth rate of the tree.
 - a. for forked trees, measure the diameter at 4.5 feet on the hill side of each fork (if split is below 4.5 feet)
4. total height of tree to nearest foot.
5. growth condition - "Open" attribute is assigned to urban trees where land conversion has occurred; "Closed" attribute is assigned to trees growing in natural settings, normally outside of urban areas.
6. Location (Latitude/Longitude)

1.03 Submittals

A. Certification: Submit certificates of inspection as required by governmental authorities. Submit manufacturers or vendor's certified analysis for soil amendments and fertilizer materials. Submit other data substantiating that materials comply with specified requirements.

B. Submit seed vendor's certified statement for each grass seed mixture required, stating botanical and common name, percentage by weight, and percentages of purity, germination, and weed seed for each grass seed species.

C. Planting Schedule: Submit proposed planting schedule, indicating dates for each type of landscape work during normal seasons for such work in area of site. Correlate with specified maintenance periods to provide maintenance from date of substantial completion. Once accepted, revise dates only as approved in writing, after documentation of reasons for delays.

D. Maintenance Instructions: Submit typewritten instructions recommending procedures to be established by Owner for maintenance of landscape work for one full year; submit prior to expiration of required maintenance period(s).

1.04 Delivery, Storage and Handling

A. Packaged Materials: Deliver packaged materials in containers showing weight, analysis and name of manufacturer. Protect materials from deterioration during delivery, and while stored at site.

B. Trees and Shrubs: Provide freshly dug trees and shrubs. Do not prune prior to delivery unless otherwise approved by Landscape Architect. Do not bend or bind-tie trees or shrubs in such manner as to damage bark, break branches or destroy natural shape. Provide protective covering during delivery. Do not drop balled and burlapped stock during delivery.

C. Deliver trees and shrubs after preparations for planting have been completed and plant immediately. If planting is delayed more than 6 hours after delivery, set trees and shrubs in shade, protect from weather and mechanical damage, and keep roots moist by covering with mulch, burlap or other acceptable means of retaining moisture.

D. Do not remove container-grown stock from containers until planting time.

E. Do not deliver wet topsoil or handle topsoil when wet.

SECTION 32 90 00 - PLANTING**1.05 Job Conditions**

A. Proceed with the complete landscape work as rapidly as portions of the site become available, work within seasonal limitations for each kind of landscape work required. Coordinate with General Contractor for when work may begin.

B. Utilities: Determine location of underground utilities and per formwork in a manner, which will avoid possible damage. (See Vanderbilt A/E Standards for further utility locating instructions.) Hand excavate, as required. Maintain grade stakes set by others until removal is mutually agreed upon by parties concerned.

C. Excavation: When conditions detrimental to plant growth are encountered, such as rubble fill, adverse drainage conditions, or obstructions, notify Owner before planting.

D. Planting time: Plant or install materials during normal planting seasons for each type of landscape work required. Correlate planting with specified maintenance periods to provide maintenance from date of substantial completion.

E. Planting Schedule: Prepare a proposed planting schedule. Schedule dates for each type of landscape work during normal seasons for such work in area of site. Correlate with specified maintenance periods to provide maintenance from date of substantial completion. Provide documentation of reasons for delays.

F. Coordination with Lawns: Plant trees and shrubs after final grades are established and prior to planting of lawns, unless otherwise acceptable to Owner. If planting of trees and shrubs occurs after lawn work, protect lawn areas and promptly repair damage to lawns resulting from planting operations.

1.06 Special Warranty

A. Warranty lawns through specified lawn maintenance period, and until final acceptance.

B. Warranty trees and shrubs, for a period of one year after date of substantial completion, against defects including death and unsatisfactory growth, except for defects resulting from neglect by Owner, abuse or damage by others, or unusual phenomena or incidents which are beyond Landscape Contractor's control.

C. Remove and replace trees, shrubs, or other plants found to be dead or in unhealthy condition during warranty period. Make replacements during growth season following end of warranty period. Replace trees and shrubs which are in doubtful condition at end of warranty period; unless, in opinion of Owner, it is advisable to extend warranty period for a full growing season.

D. Another inspection will be conducted at end of extended warranty period, if any, to determine acceptance or rejection. Only one replacement (per tree, shrub or plant) will be required at end of warranty period, except for losses of replacements due to failure to comply with specified requirements, prior to or during warranty period.

Part 2- Products**2.01 Topsoil**

A. Topsoil for landscape work is not available at site and must be furnished as specified.

B. Provide topsoil equivalent to Maury silt loam: 12-27% clay, 20-50% sand, 40-68% silt, permeability 2-6 inches per hour, low shrink-swell potential, pH 6.0-7.0. Topsoil shall have minimum of 2% organic material.

SECTION 32 90 00 - PLANTING

C. Topsoil shall be tested for sand, silt and clay percentages, organic content, pH and nutrient content by:

AGRI Systems of Texas, Inc.
15511 Baldswalle
Tomball, TX 77375
(713) 376-4412

OR

A & L Agricultural Laboratory of Memphis
411 North Third Street
Memphis, TN 38105

Contact lab before taking soil sample for directions on sampling methods to be used.

D. Topsoil shall be free of live Bermuda grass roots.

2.02 Structural Soil

A. Structural soil shall be composed of the following (by weight):

1000 parts crushed limestone, 3/4" to 1 1/2" diameter (no fines).

200 parts moist clay loam consisting of 25-40% clay, 20-40% silt and 25-30% sand, 2-5% organic matter.

30 parts dry soilmoist' granular hydrogel or equal.

B. Mix ingredients thoroughly and place in 6" lifts, compacting after each lift.

2.03 Soil Amendments

A. Lime: Natural limestone containing not less than 85% of total carbonates, ground so that not less than 90% passes 10-mesh sieve and not less than 50% passes a 100 mesh sieve.

B. Aluminum Sulfate: Commercial grade.

C. Supplemental Organic Matter: Composted rice hulls or peat moss. Leaf mold may be substituted only if sample is submitted to owner for approval prior to the start of work.

D. Bonemeal: Commercial, raw, finely ground; 4% nitrogen and 20% phosphoric acid.

E. Superphosphate: Soluble mixture of treated minerals; 20% available phosphoric acid.

F. Sand: Clean, coarse, washed sand, free of toxic materials.

G. Mulch: Organic mulch free from deleterious materials and suitable for top dressing of trees, shrubs or plants and consisting of Pine needles 3" thick while compressed.

H. Commercial Fertilizer: Complete fertilizer of neutral character, with some elements derived from organic sources and containing following percentages of available plant nutrients: for lawns, provide fertilizer with percentage of nitrogen required to provide not less than 1 lb. of actual nitrogen per 1000 sq. ft. of lawn area and not less than 10% phosphoric acid and 10% potassium. Provide nitrogen in a form that will be available to lawn during initial period of growth; at least 50% of nitrogen to be organic form.

SECTION 32 90 00 - PLANTING

I. Pre-Emergent Herbicide: "Barricade" or approved equal shall be spread in all plant beds immediately before mulching. Application rate as per label instructions.

2.04 Plant Materials

A. Quality: Provide trees, shrubs, and other plants of size, genus, species and variety shown and scheduled for landscape work and complying with recommendations and requirements of ANSI Z60.1 "American Standard for Nursery Stock", current edition.

B. Deciduous Trees: Provide trees of height and caliper listed scheduled for shown and with branching configuration recommended by ANSI Z60.1 for type and species required. Provide single stem trees except where special forms are shown or listed.

C. Provide balled and burlapped (B & B) deciduous trees with wire baskets and mechanically dug.

D. Container grown deciduous trees will be acceptable in lieu of balled and burlapped deciduous trees subject to specified limitations of ANSI Z60.1 for container stock.

E. Container grown deciduous shrubs will be acceptable in lieu of balled and burlapped deciduous shrubs subject to specified limitations for container grown stock.

F. Coniferous and Broadleafed Evergreens: Provide evergreens of sizes shown or listed. Dimensions indicate minimum spread for spreading and semi-spreading type evergreens and height for other types, such as globe, dwarf, cone, pyramidal, broad up-right, and columnar. Provide normal quality evergreens with well-balanced form complying with requirements for other size relationships to the primary dimension shown. Provide balled and burlapped (B&B) evergreens. Container grown evergreens will be acceptable subject to specified limitations for container grown stock.

2.05 Grass Materials

A. Grass Seed: Provide fresh, clean, new-crop seed complying with tolerance for purity and germination established by Official Seed Analysts of North America. Provide the following grass seed mixture: 'Tri-Fesca' hybrid fescue.

B. Sod: Improved turf type tall fescue or Bermuda grass as shown on plans. Sod shall be weed and insect free. Sod root zone thickness shall be 3/4" for fescue, 1/2" for Bermuda grass. Density shall be approved by Owner before installation.

2.06 Groundcovers

A. Provide plants established and well-rooted in removable containers or integral peat pots and with not less than minimum number and length of runners required by ANSI Z60.1 for the pot size shown or listed.

2.07 Other Materials

A. Anti-Erosion Mulch: Penn Mulch or Seed Aide applied as per manufacturer's specifications, available from Dickens Supply, Nashville. The use of straw mulch is prohibited.

B. Anti-Desiccant: Emulsion type, film-forming agent designed to permit transpiration but retard excessive loss of moisture from plant. Deliver in manufacturer's fully identified containers and mix in accordance with manufacturer's instructions.

SECTION 32 90 00 - PLANTING

C. Wrapping: Do not wrap trees unless requested by Owner.

D. Stakes and Guys: Consult with Owner to determine if staking will be required. Provide stakes and deadmen of sound new hard wood, treated softwood, or redwood, free of knotholes and other defects. Provide wire ties and guys of 2-strand, twisted, pliable galvanized iron wire not lighter than 12 gal. with zinc-coated turnbuckles. Provide not less than 1/2" diameter rubber or plastic hose, cut to required lengths and of uniform color, material and size to protect tree trunks from damage by wires. Stake trees under 3" caliper. Guy trees over 3" caliper.

Part 3 - Execution**3.01 Preparation**

A. Layout individual tree and shrub locations and areas for multiple plantings. Stake locations and outline areas and secure Owner's acceptance before start of planting work. Make minor adjustments as may be requested.

B. Preparation for lawn seeding and sodding:

1. All areas to be seeded or sodded shall be tilled to a depth of 5" and spread with 2" well-rotted rice hulls or peat moss and 1" sand unless the drawings specify otherwise. Thoroughly mix components after spreading. See Owner about modifying depth of tilling and soil amendments in tree root zones.
2. Remove all rocks over 1 inch diameter. Rake off clods to leave surface smooth, without ridges or depressions.
3. Incorporate 10-10-10 fertilizer into the top 2 inches of soil at the rate of 5 lbs/1000 square feet. Lightly drag area to smooth.
4. For sod laid in existing lawn areas, edge the borders of the area with a sod cutter and remove any excess soil from the area to insure a level surface after sod is laid.

C. Preparation for planting ground cover plants:

1. Prepare groundcover beds as per lawn preparation, item 1 and 2 above.
2. Work soil around roots to eliminate air pockets and leave a slight saucer indentation around plants to hold water. Water ground cover thoroughly by hand after planting, taking care not to cover crowns of plants with wet soils. Space plants as shown or schedule.

D. Excavation for Trees and Shrubs:

1. Excavate pits, beds and trenches with vertical sides and with bottom of excavation slightly raised at center to provide proper drainage. Loosen hard subsoil in bottom of excavation.
2. For balled and burlapped (B&B) trees and shrubs, make excavations at least twice as wide as the ball diameter and equal to the ball depth.
3. For container grown stock, excavate as specified for balled and burlapped stock.
4. Fill excavations for trees and shrubs with water and allow to percolate out before planting.

5. SECTION 32 90 00 - PLANTING

3.02 Planting Trees and Shrubs

A. Soil mix to be used to backfill shrub and tree pits shall consist of 3 parts soil removed from planting pit and 1 part composted rice hulls or peat moss.

B. Set balled and burlapped (B&B) stock plumb and in center of pit or trench with top of ball at same elevation as adjacent finished landscape. Remove rope from top of ball, cut away as much burlap as possible without disturbing root ball and remove from planting hole. Add planting soil in layers and work each layer to settle backfill and eliminate voids and air pockets. When excavation is approximately 2/3-full, water thoroughly before placing remainder of backfill. Repeat watering until no more is absorbed. Water again after placing final layer of backfill.

C. Set container grown stock as specified for balled and burlapped stock, except cut cans on 2 sides with an approved can cutter before removal; remove bottoms of wooden boxes after partial backfilling so as not to damage root balls.

D. Dish top of backfill to allow mulching. Spread pre-emergent herbicide at specified rate immediately before mulching.

E. Mulch pits, trenches and planted areas. Provide not less than 3" thickness of mulch and finish level with adjacent finish grades.

F. If deciduous trees or shrubs are moved in full-leaf, spray with anti-desiccant at nursery before moving and again 2 weeks after planting. Apply anti-desiccant using power spray to provide an adequate film over trunks, branches, stems, twigs and foliage.

A.

G. Prune, thin out and shape trees and shrubs in accordance with standard horticultural practice. Prune trees to retain required height and spread, unless otherwise directed by Owner. Do not cut tree leaders and remove only injured or dead branches from flowering trees, if any. Prune shrubs to retain natural character.

H. Remove and replace excessively pruned or mis-formed stock resulting from improper pruning.

I. Guy and stake trees immediately after planting, if requested by Owner.

3.03 Seed New Lawns

A. Acceptable times for fescue seeding are March 1-15 and September 1 to October 1. If lawn areas are to be seeded at other times, a cover crop specified by the Owner shall be planted. The cover crop shall be killed, and the area seeded with fescue at the next acceptable seeding time.

B. Sow seed at a rate of 8 pounds per 1,000 square feet.

C. Do not use wet seed or seed which is moldy or otherwise, damaged in transit or storage.

D. Sow seed using a spreader or seeding machine. Do not seed when wind velocity exceeds 5 miles per hour. Distribute seed evenly over entire area by sowing equal quantity in 2 directions at right angles to each other.

E. Rake seed lightly into top 1/8" of soil, roll lightly, and water with a fine spray.

F. Protect seeded areas against erosion by spreading Penn Mulch or Seed Aide at manufacturer's specified rate. The use of straw is prohibited.

SECTION 32 90 00 - PLANTING

G. If called for on drawings, cover sloping seeded and hydromulched areas with jute mesh fabric, anchored as specified on drawings.

I. Contractor is responsible for first mowing of seeded areas, and rolling and/or topdressing as needed after mowing to provide a smooth, level lawn.

3.04 Sodding New Lawns

A. Lay sod within 24 hours from time of stripping. Do not plant dormant sod or if ground is frozen.

B. Lay sod to form a solid mass with tightly fitted joints. Butt ends and sides of sod strips; do not overlap. Stagger strips to offset joints in adjacent courses. Work from boards to avoid damage to subgrade or sod. Tamp or roll lightly to ensure contact with subgrade. Work sifted soil into minor cracks between pieces of sod; remove excess to avoid smothering of adjacent grass.

C. Anchor sod on slopes with wood pegs to prevent slippage. Use at least 2 pegs per slab or 1 peg per running foot for long rolls of sod.

D. Water sod thoroughly by hand immediately after planting. In non-irrigated areas, Sod Contractor shall water sod thoroughly every day for two weeks after installation. In irrigated areas, Sod Contractor shall be responsible for contacting owner regarding altering watering schedules to insure survival of the sod.

E. Sod shall be rolled and tamped as necessary after watering to achieve a smooth, even surface free of detectable high or low spots. Add sifted soil and or sand to fill cracks between sod panels. Seed cracks larger than 1".

F. Sod Contractor is responsible for erecting and maintaining fencing or other barriers as needed to prevent foot or vehicle traffic over newly sodded areas. Repair of areas damaged by such traffic is the responsibility of the sod contractor.

G. Sod contractor is responsible for first mowing of sodded area and rolling and/or topdressing as needed after mowing to provide a smooth, level lawn.

3.05 Reconditioning Existing Lawns

A. Recondition existing lawn areas damaged by Contractor's operations including storage of material and equipment and movement of vehicles. Also recondition existing lawn areas where minor regrading is required.

B. Provide fertilizer, seed or sod and soil amendments as specified for new lawns and as required to provide a satisfactory reconditioned lawn. Provide new topsoil as required to fill low spots and meet new finish grades.

C. Cultivate bare and compacted areas to a depth of 5" to provide a satisfactory planting bed.

D. Remove diseased and unsatisfactory lawn areas; do not bury into soil. Remove topsoil containing foreign materials resulting from Contractor's operations including oil drippings, stone, gravel and other loose building materials.

E. Where substantial lawn remains (but if thin), mow, rake, aerate if compacted, fill low spots, remove humps and cultivate soil, fertilize, and seed. Remove weeds before seeding or if extensive, apply selective chemical weed killers as required. Apply a seeded mulch, if required, to maintain moist conditions.

SECTION 32 90 00 - PLANTING

F. Water newly planted areas and keep moist until new grass is established.

3.06 Maintenance

A. Begin maintenance immediately after planting.

B. Maintain trees, shrubs and other plants until final acceptance by pruning, cultivating and weeding as required for healthy growth. Restore planting saucers. Tighten and repair stake and guy supports and reset trees and shrubs to proper grades or vertical position as required. Restore and replace damaged wrappings. Spray as required to keep trees and shrubs free of insects and disease.

C. Maintain lawns until final acceptance by watering, fertilizing, topdressing, weeding, mowing, trimming, and other operations such as rolling, regrading and replanting as required to establish a smooth acceptable lawn, free of high and low spots and eroded or bare areas.

3.07 Cleanup and Protection

A. During landscape work, keep pavements clean and work area in an orderly condition.

B. Protect landscape work and materials from damage due to landscape operation, operation by other contractors and trades and trespassers. Maintain protection during installation and maintenance periods. Treat, repair or replace damaged landscape work as directed.

3.08 Inspection and Acceptance

A. When landscape work is completed, including maintenance, Owner will, upon request, make an inspection to determine acceptability.

B. Landscape work may be inspected for acceptance in parts agreeable to Owner, provided work offered for inspection is complete, including maintenance.

C. Where inspected landscape work does not comply with requirements, replace rejected work and continue specified maintenance until re-inspected by Owner and found to be acceptable. Remove rejected plants and materials promptly from project site.

- END OF SECTION -

APPENDIX A: SUSTAINABLE BUILDING STANDARDS

A

HOLD FOR INSERTION OF SUSTAINABLE BUILDING STANDARDS (SBS)

APPENDIX B: ACCESSIBILITY MASTER PLAN

HOLD FOR INSERTION OF VANDERBILT ACCESSIBILITY MASTER PLAN

APPENDIX C: LANDSCAPE STRATEGIC PLAN

A

HOLD FOR INSERTION OF LANDSCAPE MASTER PLAN

APPENDIX D: MOBILITY MASTER PLAN

A

HOLD FOR INSERTION OF VANDERBILT MOBILITY MASTER PLAN

APPENDIX E: Energy Modeling Guidelines**B**

1.0 Purpose

To establish expectations for value based energy modeling services necessary to inform the design, selection and construction of Vanderbilt facilities and facility infrastructure in support of and in conjunction with the established Vanderbilt Master Planning and Sustainable Buildings standards.

1.1 Key References

- A. ANSI/ASHRAE Standard 209-2018 Energy Simulation Aided Design for Buildings Except Low-Rise Residential Buildings
- B. Published Vanderbilt utility and emissions rates calculated annually from Vanderbilt measured actuals and TVA's annually published emissions rate.
- C. VU Energy Standard
- D. VU A&E Guidelines
- E. Vanderbilt Sustainable Buildings Standard

1.2 Defined objectives

- A. Contract energy modeling services to provide an assessment of proposed envelope and infrastructure options under consideration in the proposed design.

This should shall include an impact assessment for:

- Building total energy consumption projection
 - System, equipment and infrastructure budget
 - Construction, feasibility and schedule.
 - Operations and Maintenance
 - Utility operating expense
- B. Provide energy modeling in the Site EUI format using current published Vanderbilt utility and emissions rates.
 - C. Produce the Site EUI summary report as (12) monthly energy consumption profiles by utility (elect, steam, chilled water, hot water, gas) as applicable, which combined represent the total annual energy consumption projection for the facility.
 - D. Produce Monthly Benchmark reports comparing modeled energy consumption projections (by utility), to post occupancy measured energy consumption data.
 - E. Provide energy data support and validation for stated project design certification objectives (LEED, Living Building etc.).
 - F. Energy Model Reconciliation Report, required when the design Site EUI differs from the post occupancy actual by more than 10%.

2.0 Process Requirements

The Vanderbilt Energy Modeling process will be in compliance with the direction provided in ASHRAE Standard 209-2018.

2.1 Software

The Energy Modeling software proposed for use on each Vanderbilt project will be identified in the **Energy Modeling RFP**, by name and version, along with the name and certifying credentials of the proposing Energy Modeling services providers. The proposed software must be “*whole-building simulation software*,” meeting the requirements of ASHRAE 90.1 G2.2.

2.1 Scope of Work

The scope of “Energy Modeling Services” required for each project will be defined in the **Owner’s Project Requirement (OPR)** process in accordance with ASHRAE 209-2018 Section 4.2.1, identifying each of the *Modeling Cycles* applicable to the specific project. Modeling Cycles are define in reference ASHRAE 209-2018 Section 6.1-6.7.

2.2 Energy Performance Goals

As referenced in ASHRAE 209-2018 Section 5.6.1, prior to Modeling Cycle #2 the design team members in conjunction with the Energy Modeling Services provider, shall develop and document the energy performance goals identified in the OPR and reflective of Vanderbilt Master Planning and Sustainable Buildings standards.

2.3 Energy Benchmarking

Energy performance projections shall be made as a Site EUI evaluation. Comparisons to industry standards, design challenge goals or comparative regional projects, shall be normalized using the current “Vanderbilt Measured Emissions Variables” for onsite distributed utilities.

2.4 Climate Reference

Energy models constructed for Vanderbilt projects will use **Nashville International Airport, Weather Station 723270** as the source for climate data required for population of the model.

3.0 Deliverables

Key “Energy Modeling” deliverables will be the applicable *Modeling Cycle* output reports required at each project phase, design, as-built, and post occupancy.

3.1 Design Energy Consumption Profile

Vanderbilt will require a specific (12) month view of the modeled annual energy by month, by utility (example Table 1).

Annual Energy consumption projections by month by utility (forecast as stacked column graph and data table)

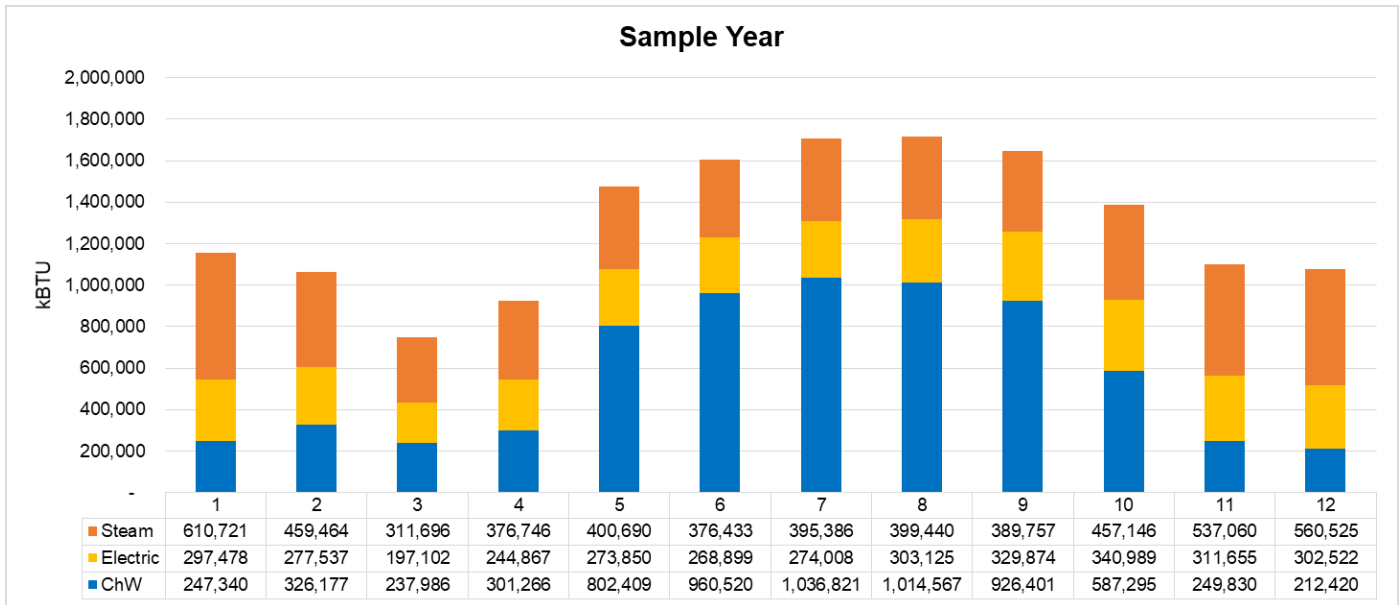

Sample 1

3.2 Post-Occupancy Modeling Reports

Post Occupancy reporting will compare post occupancy consumption each month, for 12 consecutive months, by utility to the *Design* predicted values for the corresponding monthly post occupancy consumption data.

Monthly/quarterly design vs. actual comparison by month, by utility (design vs. actual comparison with data table)

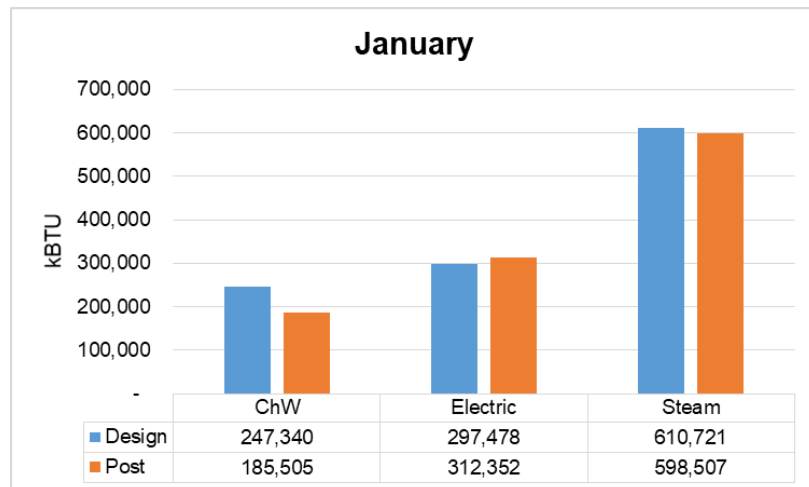

Sample 2

VANDERBILT UNIVERSITY**Energy Standards**

Building Automation System (BAS) – any new construction or facility renovation requires that BAS infrastructure be installed or upgraded to provide monitoring, measurement, trending of system points and support advanced energy saving control routines to include but not limited to:

- Demand control ventilation
- Night setback
- Temperature and static pressure reset
- Advanced scheduling
- Bacnet interface to lighting control
- Reporting and fault detection

Lighting Control - any new construction or facility renovation that includes lighting installation or upgrade must be equipped for lighting control. Lighting control shall be applied according to the opportunity reduce or minimize consumption. The “best fit” analysis must be a joint effort with the construction/renovation team and Plant Operations. Energy saving lighting strategies to include:

- Scheduling
- Occupancy/Vacancy control
- Dimming
- Daylight harvesting
- Setback – reduced lighting levels
- Light Level Tuning
- Bacnet integration to the BAS
- Reporting and fault detection

Vanderbilt A&E Standards identify (2) lighting control systems that each have the full range of control capability supporting group, zone, floor or fixture level control. These systems are supported with a central data server and a full suite of central programming, data collection and analytic tools. If the scope and cost benefit analysis does not warrant full lighting control the minimum of occupancy/vacancy sensing control will be applied.

Metering – any new construction or facility renovation requires support for the VU “Total Energy Accountability” objective. Each facility will have main line metering for each utility input to include electricity, domestic water, steam, chilled water and natural gas, as applicable. The utility metering must integrate to the buildings BAS system where the consumption data will be trended and stored. Utility data will also be passed to the campus energy data warehouse system (currently Building Logix) as a bacnet device on the VU Facilities Network or as a bacnet export from the facility BAS.

- Sub-metering of utilities should be included when a single load, system or area is responsible for a significant percentage of the facility’s energy use i.e. clean room.

APPENDIX F: Commissioning and OPR

C
